

# SUBMICROFILTER

Dear Customer,

Thank you for your confidence in our product.

In the following pages you will find the technical data required for the trouble-free installation and maintenance of these pneumatic components. Please read the instructions fully to ensure that the product will give you long, trouble-free service.

**Warning:** Servicing and repair work must only be carried out by a qualified technician.



## 1. TECHNICAL DATA

<i>Characteristics</i>			Pressures are gauge pressure	
Port size			G3/8	G1/2
Condensate drainage			standard: manual on request: semiautomatic with pressure relief	
Installation			vertical (bowl downwards)	
Medium and ambient temperature range	$\vartheta_{\min}$ $\vartheta_{\max}$	°C °C	+1,5 (other temperatures on request) +50 at 10 bar	
Weight (mass)		kg	0.5	0,5
<i>Pneumatic Characteristics</i>				
Operating pressure range inlet	$p_{1\min}$ $p_{1\max}$	bar	0 16	
Maximum flow rate ①	$Q_{\max}$	l/min m <sup>3</sup> /h	<b>600</b> <b>36</b>	<b>600</b> <b>36</b>
Pressure drop at maximum flow rate	$\Delta p$	bar	ca. 0,07 with new filter element up to ca. 0,3 in operation (saturated element)	
Filtration efficiency at maximum flow rate	$\eta$	%	over 99,999%, solids >0,01 $\mu\text{m}$ (DOP or BS 3928, 2577)	

① at 6,3 bar

## 2. INSTALLATION INSTRUCTIONS

**Warning:** The unit must only be used in industrial applications for compressed air.

 To avoid danger of injuries, the compressed air system must be fully depressurized while pneumatic components are being installed.

**Note:** A filter-water-separator with pore size 5 $\mu$ m (yellow) must always be installed before the submicrofilter (as close to it as possible). The bowl must not come into contact with the following materials (whether in liquid or gaseous form): acetone, benzene, brake fluid, chloroform, acetic acid, glycerine, methanol, carbon bisulphide, tri-, tetra- and per-compounds, toluene, xylene (cellulose thinners) and high flash-point synthetic oils (e.g. phosphoric ester base, etc.). If in doubt, please consult your sales contact



1. Carefully clean rust particles or other dirt out of the air line.
2. Fit a mounting bracket, if applicable.
3. Connect the air line to the submicrofilter (check flow direction!).
4. Turn on the compressed air supply.

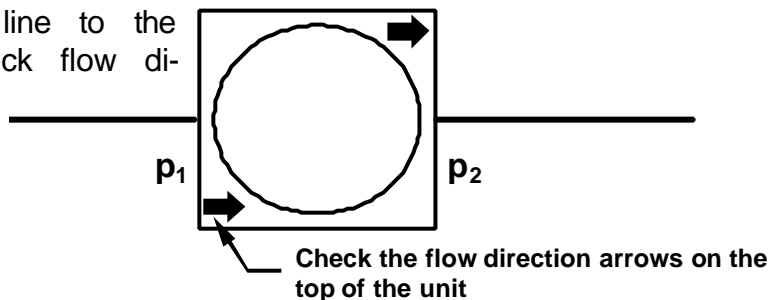

## 3. MAINTENANCE

### 3.1. Manual Drainage

To drain condensate from the bowl, press the plastic tabs together as shown  $\Rightarrow$  this opens the valve.

To drain condensate from the bowl, press the plastic tabs together as shown  $\Rightarrow$  this opens the valve.

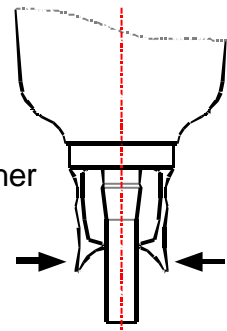

### 3.2. Cleaning

As soon as serious pressure drop is observed, replace the filter element.

The filter element cannot be washed out and must always be replaced.

The bowl and other plastic parts should only be cleaned with warm water and normal washing-up liquid.

## 4. DISMANTLING

**Warning:** To avoid danger of injuries, the unit must only be dismantled with the pneumatic system completely depressurized!



1. Press down the unlocking latch of the locking ring and turn the bayonet ring ⑤ to the left.
2. Remove the bowl ⑥ and the bayonet ring.
3. Screw the filter insert ③ out of the housing ①.
4. Remove the gasket ② from the filter insert ③.
5. Take the O-ring  $\varnothing 48 \times 2$  ④ out of the housing ①.

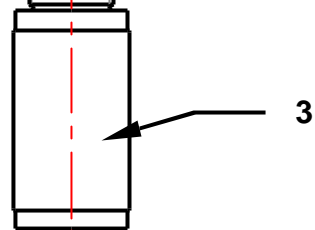
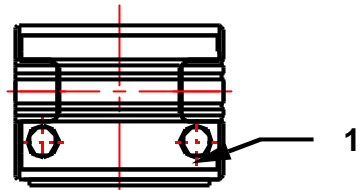

## 5. REASSEMBLY

Reassembly of the unit is carried out in reverse order to dismantling.

**Note:** If new seals are fitted, grease them lightly before fitting.



1. Place the O-ring  $\varnothing 48 \times 2$  ④ in the housing ①.
2. Push the gasket ② on to the filter insert ③.
3. Screw the filter insert ③ into the housing ①.
4. Insert the bowl ⑥ and bayonet ring with spigot back into the housing and lock by turning to the right.

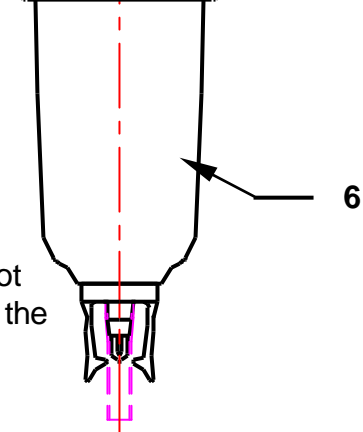

## 6. FITTING THE BOWL GUARD

The bowl guard kit consists of:

- locking ring
- bowl guard and
- bayonet ring

Fitting:

First remove the bowl, then proceed as follows:

1. Take the locking ring ① out of the bayonet ring ④ (using some force if necessary).
2. Pull the bayonet ring ④ off the bowl ②.
3. Fit the bayonet ring ④ and bowl guard ③ (from the kit) together.
4. Insert the bowl ② into the bayonet ring ④.
5. Insert the locking ring ① into the bayonet ring ④.

**Note:** The unlocking latch (arrow) must line up with the recess in the bayonet ring.

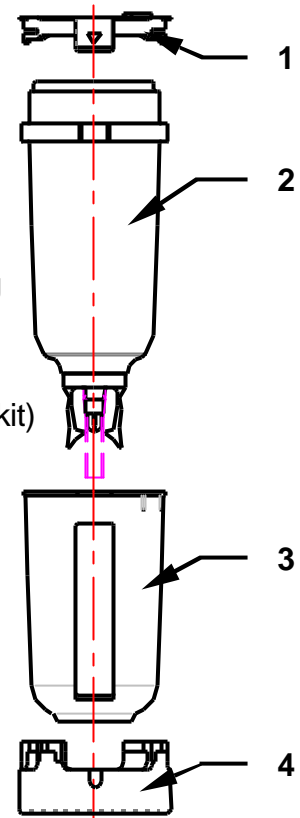

## 7. DISPOSAL

The method of disposal of packaging and discarded parts must comply with local regulations.

The supplier will take over responsibility for the disposal of used filter inserts if they are returned to him.

## 8. ASSEMBLY OF SEVERAL COMPONENTS

Only components of the same size can be assembled into combined units.

1. Remove the black cover plates from the inlets and outlets of the components you wish to assemble. The coloured cover plates remain in place.
2. Turn the component so that the flange surface which is to be joined to the other component is on top.
3. Lay the O-ring ① from the coupling kit on the flange surface.
4. Place the hexagon nuts ② in the recesses on the component.
5. Place the other component on the flange surface.
6. Place the clamping cones ④ with the screws ③ in the recesses on the components.
7. Tighten the clamping screws.

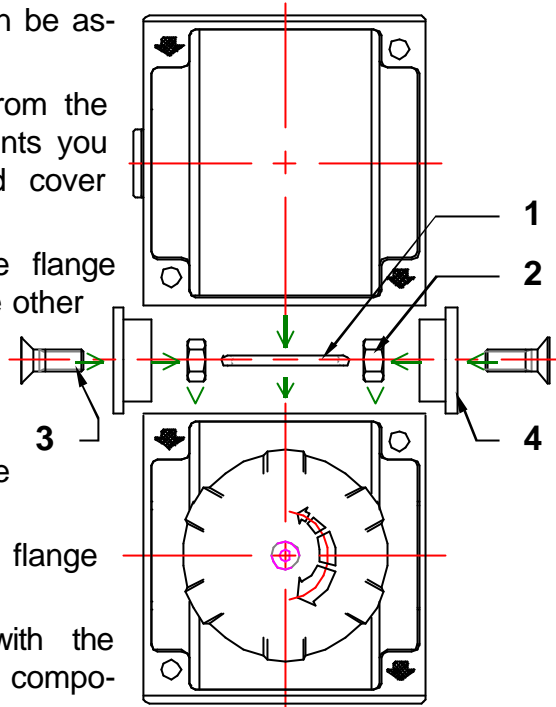

## 9. FITTING THE MOUNTING BRACKET

1. Remove the prestamped parts which cover the through-holes on both sides of the unit.
2. Fit the mounting bracket and secure it with the screws provided. Tighten them with a screwdriver.

Note: The mounting bracket can be fitted with the mounting strap either upwards or downwards.

