

# ACTIVATED CARBON FILTER

Dear Customer,

Thank you for your confidence in our product.

In the following pages you will find the technical data required for the trouble-free installation and maintenance of these pneumatic components. Please read the instructions fully to ensure that the product will give you long, trouble-free service.

**Warning:** Servicing and repair work must only be carried out by a qualified technician.



## 1. TECHNICAL DATA

<i>Characteristics</i>			Pressures are gauge pressure	
Port size			G3/8	G1/2
Installation			vertical (bowl downwards)	
Medium and ambient temperature range	$\vartheta_{\min}$	°C	+1,5	(other temperatures on request)
	$\vartheta_{\max}$	°C	+50 at 10 bar	
Weight (mass)		kg	0,5	0,5
<i>Pneumatic Characteristics</i>				
Operating pressure range inlet	$p_{1\min}$	bar	0	
	$p_{1\max}$		16	
Recommended flow rate ①	$Q_n$	l/min	<b>600</b>	<b>600</b>
		m <sup>3</sup> /h	<b>36</b>	<b>36</b>
Pressure drop at recommended flow rate	$\Delta p$	bar	ca. 0,07	
Filtration efficiency for oil vapour	$\eta$	%	99,999%, residual oil content: 0,003ppm	

① at 6,3 bar

## 2. INSTALLATION INSTRUCTIONS

**Warning:** The unit must only be used in industrial applications for compressed air, but can also be used in medical engineering applications. NOTE! The housing and activated carbon filter are not sterilized (not suitable for steam sterilization)! To avoid danger of injuries, the compressed air system must be fully depressurized while pneumatic components are being installed.

**Note:** A submicrofilter must always be installed before the activated carbon filter (as close to it as possible). The bowl must not come into contact with the following materials (whether in liquid or gaseous form): acetone, benzene, brake fluid, chloroform, acetic acid, glycerine, methanol, carbon bisulphide, tri-, tetra- and per-compounds, toluene, xylene (cellulose thinners) and high flash-point synthetic oils (e.g. phosphoric ester base, etc.). If in doubt, please consult your sales contact.

1. Clean out the air line carefully.
2. Fit a mounting bracket, if applicable.
3. Connect the air line to the activated carbon filter (check flow direction! ⇒ the wrong flow direction will damage the filter element irreparably!).
4. Turn on the compressed air supply.

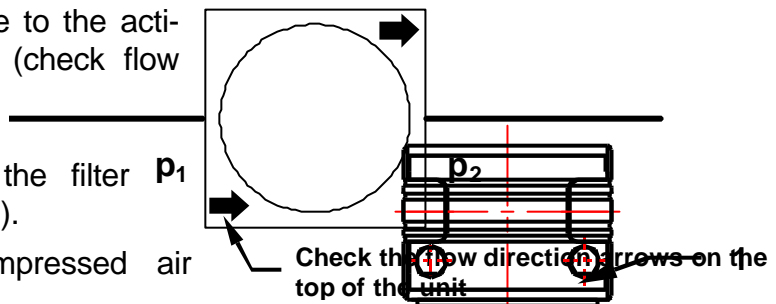

## 3. MAINTENANCE

### 3.1. Changing the Filter Element

As soon as the cleaning power of the activated carbon is exhausted the filter element must be changed. The filter element cannot be washed out. The bowl and other plastic parts should only be cleaned with warm water and normal washing-up liquid.

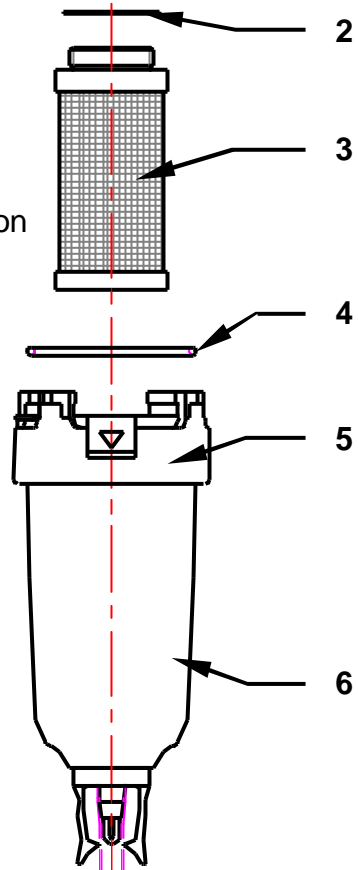

## 4. DISMANTLING

**Warning:** To avoid danger of injuries, the unit must only be dismantled with the pneumatic system completely depressurized!

1. Press down the unlocking latch of the locking ring and turn the bayonet ring ⑤ to the left.
2. Remove the bowl ⑥ and the bayonet ring.
3. Screw the filter insert ③ out of the housing ①.
4. Remove the gasket ② from the filter insert ③.
5. Remove the O-ring  $\varnothing 48 \times 2$  ④ from the housing ①.

## 5. REASSEMBLY

Reassembly of the unit is carried out in reverse order to dismantling.

1. Place the O-ring  $\varnothing 48 \times 2$  ④ in the housing ①.
2. Push the gasket ② on to the filter insert ③.
3. Screw the filter insert ③ into the housing ①.
4. Insert the bowl ⑥ and the bayonet ring with spigot back into the housing and lock by turning to the right.

## 6. FITTING THE BOWL GUARD

The bowl guard kit consists of:

- locking ring
- bowl guard and
- bayonet ring

Fitting:

First remove the bowl, then proceed as follows:

1. Take the locking ring ① out of the bayonet ring ④ (using some force if necessary).
2. Pull the bayonet ring ④ off the bowl ②.
3. Fit the bayonet ring ④ and bowl guard ③ (from the kit) together.
4. Insert the bowl ② into the bayonet ring ④.
5. Insert the locking ring ① into the bayonet ring ④.

**Note:** The unlocking latch (arrow) must line up with the recess in the bayonet ring.

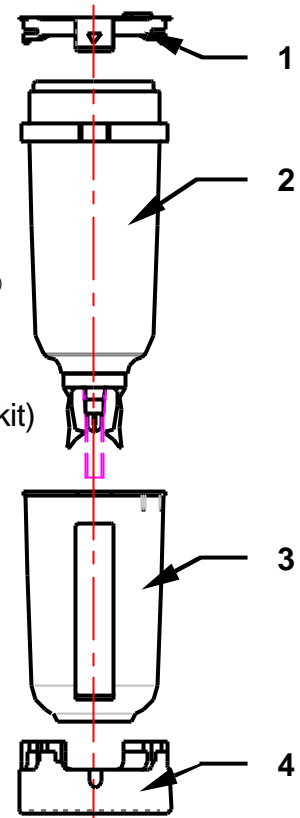

## 7. DISPOSAL

The method of disposal of packaging and discarded parts must comply with local regulations.

The supplier will take over responsibility for the disposal of used filter inserts which are returned to him.

## 8. ASSEMBLY OF SEVERAL COMPONENTS

Only components of the same size can be assembled into combined units.

1. Remove the black cover plates from the inlets and outlets of the components you wish to assemble. The coloured cover plates remain in place.
2. Turn the component so that the flange surface which is to be joined to the other component is on top.
3. Lay the O-ring ① from the coupling kit on the flange surface.
4. Place the hexagon nuts ② in the recesses on the component.
5. Place the other component on the flange surface.
6. Place the clamping cones ④ with the screws ③ in the recesses on the components.
7. Tighten the clamping screws.

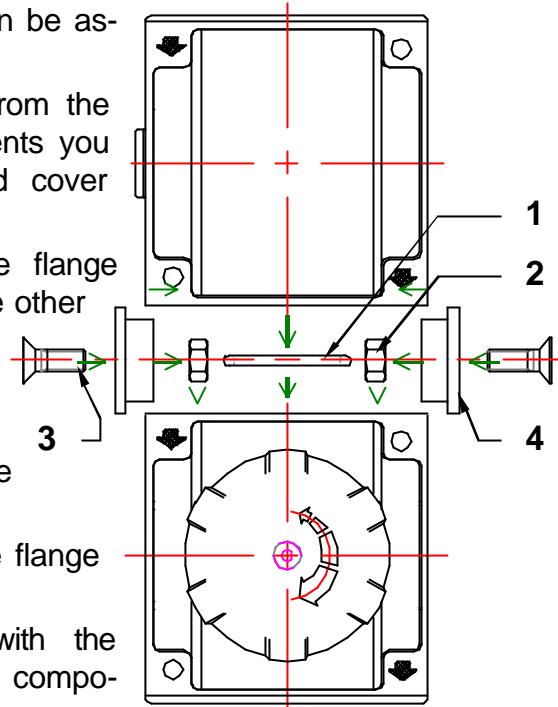

## 9. FITTING THE MOUNTING BRACKET

1. Remove the prestamped parts which cover the through-holes on both sides of the unit.
2. Fit the mounting bracket and secure it with the screws provided. Tighten them with a screwdriver.

Note:  The mounting bracket can be fitted with the mounting strap either upwards or downwards.

