

IM10 Valve Islands

Operating Instructions - english

aerospace
climate control
electromechanical
filtration
fluid & gas handling
hydraulics
pneumatics
process control
sealing & shielding



ORIGA

ENGINEERING YOUR SUCCESS.

Contents

1	General notes for users	3
2	Warranty	4
3	Modifications and changes	4
4	Safety	5
	4.1 General safety notes	5
	4.2 Use in accordance with intended purpose	5
	4.3 Operating personnel	5
5	Transport	5
6	Description of product	5
7	Fitting instructions	6
	7.1 General	6
	7.2 Fitting the unit	6
	7.3 Pneumatic connection	6
	7.4 Electrical connections	7
8	Commissioning the unit	8
	8.1 Preparation	8
	8.2 Manual operation	8
9	Technical data	9
10	Maintenance / repair	10
	10.1 Cleaning	10
	10.2 Lubrication	10
	10.3 Replacing individual valves	10
	10.4 Spare parts and accessories	10
11	Disposal	10
12	Manufacturer's statement	11

1 General notes for users

1.1 Significance of the operating instructions

The operating instructions are an important part of the unit and should

- always be kept within easy reach (this applies up to the end of the service life of the unit);
- be handed on with the unit if passed on to others by sale, rental or otherwise.

This equipment is subject to unavoidable residual risks for persons and property. For this reason, personnel working with the equipment, either for the purpose of transport, setting up, operating, servicing or repair, must have received suitable training and be familiar with the possible risks. For this purpose it is imperative that the operating instructions, and in particular the safety notes, are carefully read, understood and observed. If the respective person is not at all or only inadequately familiar with the operating instructions, all claims for liability against **Parker-Origa GmbH** are void.

Keep for future use!

1.2 Duty of the company in charge of the machine

In accordance with the EU Directive for the use of work equipment 89/655/EEC art. 6(1) and 7 as well as the EU Framework Directive 89/391/EEC art. 1(1) and art. 6(1) the company in charge of operating the machine has a duty to instruct all persons in charge of assembly/fitting, operating, servicing, repairing or dismantling the unit, particularly with respect to all safety matters.

In accordance with the EU Directive for the use of work equipment 89/655/EEC art. 4a the company in charge of operating the equipment has a duty to check the machine prior to start-up, after repairs and faults.

In addition, the company in charge of operating the equipment needs to ensure that the units are used in accordance with their intended purpose.

1.3 Copyright

Parker-Origa GmbH has the copyright to these Operating Instructions.
Copyright 2008 ©.

These Operating Instructions shall not be copied, neither fully nor in part thereof, nor distributed, nor shall they be subjected to unauthorised use for purposes of competition. In addition, they shall not be notified to others. All violations involving copyright can result in legal action.

1.4 Identification plate

The identification plate is fixed next to the electrical connection.

It contains the following data:

- Ident number
- Type designation
- Valve assignment
- Date of assembly, month/year

1.5 Monitoring products

We aim to produce safe products that incorporate state-of-the-art technology. For this reason, we will monitor our products continually, also after they have been delivered. In the case of any repeated faults or problems with our products we ask you to inform us immediately.

2 Warranty

We reserve the right to make alterations to these Operating Instructions as well as to make alterations to technical details with reference to data and illustrations as contained in these Operating Instructions.

Parker-Origa GmbH issues no quality and durability guarantees, as well as no guarantees for the suitability for certain purposes. This must be expressly agreed in writing.

Public statements, praise or advertising are not statements with reference to quality.

The warranty rights of the user presuppose that he notifies the deficiency immediately and describes it precisely in his writ of complaint. Under no circumstances is **Parker-Origa GmbH** responsible for damage to the product itself or for consequential damage caused by the product, as caused by incorrect and faulty handling of the product. Insofar as **Parker-Origa GmbH** is responsible for a deficiency, **Parker-Origa GmbH** is entitled to make a choice for repair/improvement or substitute delivery.

All valve islands IM10 are provided with an identification plate within the framework of ISO 9000, that is bound to a valve block. This identification plate shall not be removed or destroyed in any way.

A liability of Messrs **Parker-Origa GmbH** – irrespective of the legal reason – exists only in the event of intentional or gross negligence, culpable injury to life, body, health, in the event of deficiencies with malicious intent of deception or whose absence has been expressly guaranteed.

Furthermore, liability to the extent according to the product liability law for injury to persons or material damage on objects used privately. In the event of culpable violation of essential contractual obligations,

Parker-Origa GmbH is liable also in the case of minor negligence, however, limited to the contract-typical foreseeable damage.

All and any other claims are ruled out.

The warranty is cancelled in the event of non-observance of these Operating Instructions, the relevant legal provisions as well as further instructions of the supplier.

In particular, we are not responsible for stoppages caused by modifications by the customer or other persons. In such cases, we charge the normal repair costs. These are also charged of the inspection if no fault can be found on the equipment.

This regulation also applies during the warranty period.

There are no claims to the supply of previous equipment versions or to the re-equipping possibility for already supplied equipment to the current series status in each case.

3 Modifications and changes

It is not permitted to make any modifications or changes to the construction or the safety arrangements of the IM10 valve island without prior written approval by **Parker-Origa GmbH**. Any modification or change without such approval will preclude any liability on the part of **Parker-Origa GmbH**.

Spare parts may only be replaced after consultation with our service technicians or by the service technicians themselves. Generally it is imperative that no safety or protective equipment is dismantled or rendered non-functional.

Where special components are fitted, the fitting instructions of the manufacturer must be observed!

In addition, the following rules and regulations apply as a matter of course:

- the applicable regulations for health and safety at work,
- generally accepted rules for the safe operation of machinery,
- the EU Directives,
- any special regulations of the respective country/state.



4 Safety

4.1 General safety notes

The equipment has been constructed in accordance with state-of-the-art technology and current regulations. Special emphasis has been placed on the safety of operators. This has been confirmed in the manufacturer's statement.

In addition, the following rules and regulations apply as a matter of course:

the applicable regulations for health and safety at work, generally accepted rules for the safe operation of machinery, the EU Directives, any special regulations of the respective country/state as well as any other relevant standards.

Any repairs may only be carried out directly by the manufacturer or by agents that have been authorised by the manufacturer. Any interference with and changes to the equipment are not permitted and, in addition, will void any claims under the guarantee or for liability.

However, the following activities are excepted: servicing the equipment carried out by properly trained personnel, repairs using original spare parts and maintenance tasks carried out in accordance with the regulations.

4.2 Use in accordance with intended purpose

The IM10 valve islands are exclusively intended for the control of pneumatic equipment. It is imperative that the specified general and specific intended uses and their limits for the respective types of valves are observed (see catalogue S10 valves).

Any other use of the equipment or using the equipment beyond its limits is considered as not in accordance with the intended purpose. The manufacturer will not accept any liability for any damage resulting therefrom. The risk must be purely born by the operator. Since IM10 valve islands can be deployed in very diverse areas, the responsibility for the specific application changes over to the operator as soon as the equipment is used in the respective application.

4.3 Operating personnel

The IM10 valve islands have been constructed in accordance with state-of-the-art technology and the recognised safety rules and regulations. Nevertheless, it is possible that risks arise during the application of the equipment. For this reason, the units may only be fitted and operated by competent and trained personnel and only be deployed in accordance with the intended purpose. All persons involved in the fitting, operation, servicing, repair or dismantling of IM10 valve islands must have read and understood these operating instructions and in particular section 4.1 „Safety“.

5 Transport

Any transport damage and missing parts should be reported immediately to the transport company and Parker-Origa GmbH or the respective supplier!

During intermediate storage the following needs to be observed: storage should be dry, free from dust and vibrations and, if in the open, under cover.

6 Description of product

Detailed information about dimensions, space requirements and weights are contained in the catalogue for the IM10 valve island. All IM10 valve islands can be fitted in any position.

We reserve the right to make technical changes!

The IM10 valve islands are generally fitted in applications where it is necessary to centrally control several items of pneumatic equipment with one joint electrical connection.

The functionality required for this type of application is realised by the combination of several individual valves.

The unit is fitted with cover plates, which facilitates the extension of the island with further valves at a later date.

Construction features

- Combined supply of the valve connections 1, 3 and 5 with a continuous RPS manifold.
- Combined electrical connection on the face of the unit.
- The valves are arranged at right angles to the continuous RPS manifold.
- The connections to valves 2 and 4 face upwards.

7 Fitting instructions

7.1 General



Please observe the notes in the catalogue as well as the operating instructions of the respective pneumatic equipment when fitting the units and connecting the compressed air.

Any fitting must always comply with current regulations and also ensure that the IM10 valve island is not subject to torsional forces. All connections and operating elements must be reachable and it must be possible to read the type plate.

Any sources of risks in existence between the Parker-Origa products and equipment by the customer to be removed or secured by the operator.

7.2 Fitting the unit

Only fix the IM10 valve island using the bore holes in the RPS manifold (base plate). When fitting the unit to DIN bars, use the appropriate clamp fixings (available as accessories).

7.3 Pneumatic connection

- Connect the compressed air on the face of the unit to the RPS manifold to connection 1 in the centre.
- Connect the return air on the face of the unit to the RPS manifold to the connection 3 and 5 on the sides.
- It is possible to separate the supply and return channels into one or several pressure areas using a channel divider (available as an accessory).
- The connection to the valve exit ports 2 and 4 are on top of the unit.

The pipelines and fittings used should have a cross section that is sufficient for the maximum anticipated compressed air requirement.

If the cross section of the compressed air supply from the face of the unit is not sufficient you can use an additional compressed air connection through an intermediate feed arrangement.

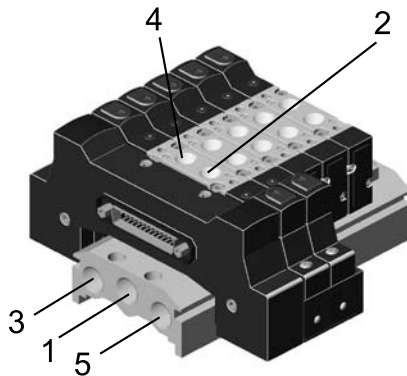

7.4 Electrical connections

For electrical connection, a 25-pole D-connector can be plugged in on the face of the unit. It is possible to connect up to 18 solenoid valves (monostable) and 11 solenoid valves (bistable).

Pins 16 to 22 can be used optionally for connection of the right-hand or left-hand side.

For the electrical connection see the wiring diagram below.

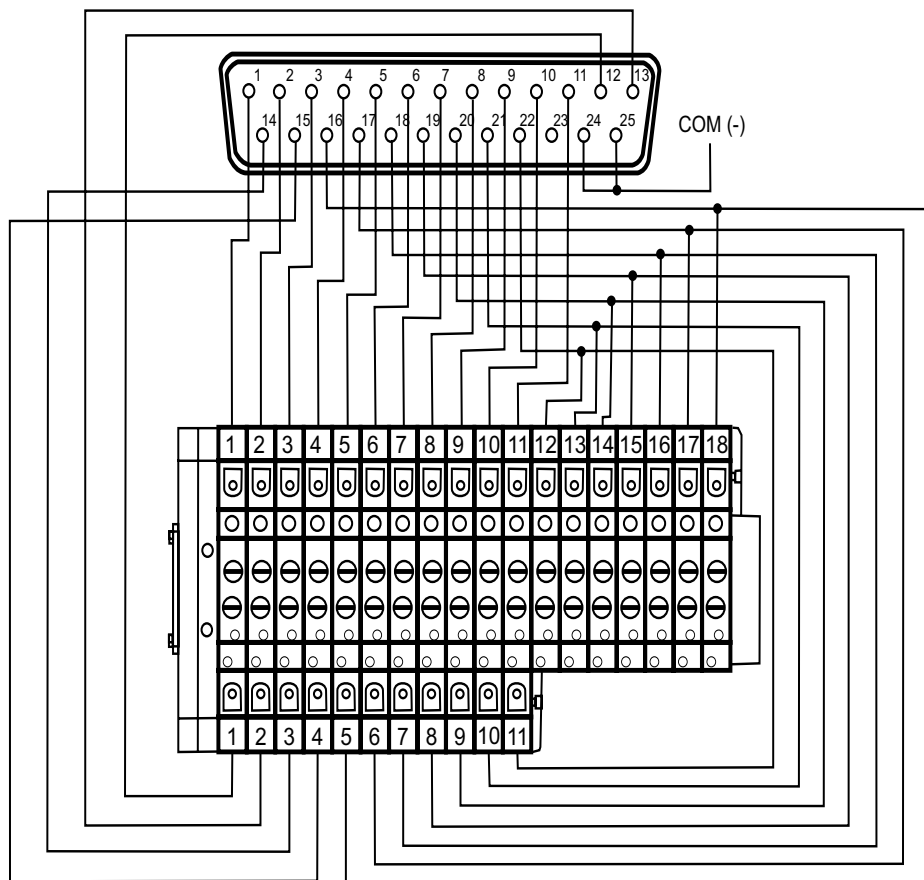

Electrical connection for IM10 valve island

8 Commissioning the unit

8.1 Preparation

The IM10 valve island can cause fast movements with great force in connected machinery. If the safety regulations are not observed, this may lead to injury through trapping or damage through collision with other parts of the installation.

Warning:

Prior to commissioning you should check:

- that the connections have been carried out correctly and
- that the movement range of connected equipment is free from any obstacles.

Initially, the IM10 valve island should be connected at low pressure in order to ascertain possible areas of collisions. These must be eliminated immediately.



8.2 Manual operation



Risk of injury or damage!

It is imperative to ensure that there is no risk from uncontrolled movements when operating the valves manually.

■ Hold-down function:

- Use a screwdriver, size 3mm
- Operate by pressing vertically

The manual hold-down operation is suitable for valves controlled by impulse.

■ Locking function:

- Use a screwdriver, size 3mm.
- Operate by pressing vertically and subsequently turning clockwise by 90°.
- Release the valve by turning anticlockwise by 90° and remove the screwdriver.

The manual locking operation is suitable for valves controlled by permanent signal.

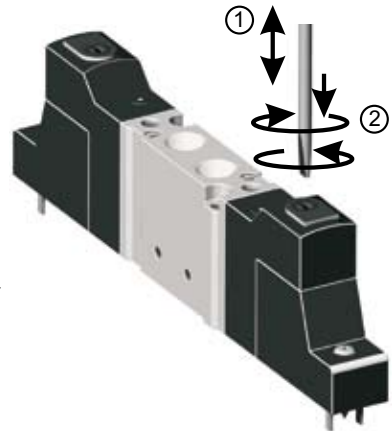

9 Technical data

IM10 Valve Island

Parameters	Symbol	Unit	Designation
Voltage types			Direct voltage
Range of ambient temperature (min/max)	q	°C	-5 to +50
Nominal voltage	U_n	V	24, 12 ± 10%
Start-up input		VA (W)	1,1 at U_n
Continuous input		VA (W)	1,1 at U_n
duty cycle	ED	%	100
Type of protection			IP65 nach DIN40050 *)
Class of insulation material			IP65 in acc. with DIN40050 *)
Connector			25-pole D sub-connector (male)
Function display			LED
Number of outputs			max. 22, max. 18 (monostable)
Pneumatic parameters see technical data of the respective valve in the catalogue			

*) only in combination with D sub-connector in IP 65 (see illustration)

NOTE:



The protection type IP 65 can only be achieved when using D sub-connectors with a rubber seal gasket.



Rubber seal gasket

10 Maintenance / repair



Maintenance and repair work shall only be carried out by specially trained and instructed persons !

The machine or the working zone must be cordoned off for safety purposes as required !

It is not permitted to carry out maintenance or repair work unless the compressed air has been disconnected and all pressure released to atmosphere.

10.1 Cleaning

The IM10 valve island must be kept free from dirt at all times, in particular the surfaces of the magnet and pilot valves. Use only cleaning materials that are not aggressive to the materials to be cleaned.

10.2 Lubrication

The valves are self-lubricating for their service life.

10.3 Replacing individual valves

All valves can be replaced irrespective of their location in the unit.

Procedure:

- Release the bolts on solenoid coils and valve.
- Take the valve off the valve island.
- Clean the seals and RPS manifold; replace defective seals.
- Fit the bolt connections to the new valve.
- Fix the various parts to the new valve in accordance with the illustration (Valve fixing bolts, solenoid fixing bolts, flat magnet sealing gasket and O-ring for solenoid bolt head.)
- Place valve sealing gasket onto manifold or valve, depending on which one is facing upwards.
- Refit the valve to the manifold – making sure that it is aligned correctly: the inscription must point towards the electrical connection.
- Tighten the bolts of the valve to a torque of 2 Nm
- Tighten the solenoid bolts to a torque of 1 Nm.

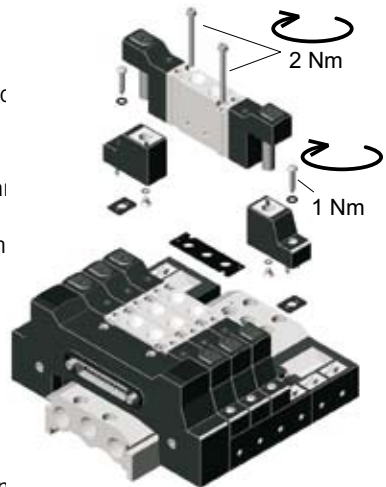

10.4 Spare parts and accessories

For replacement valves and solenoid coils, see catalogue for modular compact valves S10-1/8.

For accessories for the IM10 valve island see catalogue for IM10 valve island.

11 Disposal

It is important that statutory and other regulations governing the disposal of polluting materials are observed.

12 Manufacturer's statement

In the sense of the EU-Directive Machines
(89/392/EWG, replaced by 98/37/EG, annex II B)

The construction of the IM10-valve islands

of the types: **IM10 - Q6**
IM10 - 1/8

are developed, designed and manufactured in compliance with the EU-Directive Machines 98/37/EG, under the sole responsibility of

Messrs Parker-Origa GmbH
Industriestraße 8
D-70794 Filderstadt

The following harmonising standards have been applied:

- DIN EN 292, Safety of Machines, Equipment and Plants.
- DIN EN 60204.1, Electrical Equipment for Industrial Machines.
- DIN EN 983, Safety requirements for fluid-handling plants and components

A complete technical documentation is available.

The start-up of the valve island(s) is forbidden until it is determined that the machine/plant, into which the valve island(s) are to be built, comply as required with the provisions of the EU-Directiv Machines.

The IM10 valve islands are not covered by the Directive for Pressure Equipment

Filderstadt, January 2004



Dr. Ing. Erhard Fritz
Managing Director

Sales Offices Worldwide

AE – United Arabien Emirates

Dubai
Tel: +971 4 8875600
parker.me@parker.com

AR – Argentina, Buenos Aires
Tel: +54 3327 44 4129

AT – Austria, Wiener Neustadt
Tel: +43 (0)2622 23501-0
parker.austria@parker.com

AT – Austria, Wiener Neustadt
(Europa Oriental)
Tel: +43 (0)2622 23501 970
parker.easteurope@parker.com

AT – Austria, Wiener Neustadt
Parker Origa Pneumatik GmbH
Tel: +43 2622 26071-269

info-hoat-sales.pn@parker-origa.com

AU – Australia, Castle Hill
Tel: +61 (0)2-9634 7777

AZ – Azerbaijan, Baku
Tel: +994 50 2233 458
parker.azerbaijan@parker.com

BE/LX – Belgium, Nivelles
Tel: +32 (0)67 280 900
parker.belgium@parker.com

BR – Brazil, Cachoeirinha RS
Tel: +55 51 3470 9144

BY – Belarus, Minsk
Tel: +375 17 209 9399
parker.belarus@parker.com

CA – Canada, Milton, Ontario
Tel: +1 905 693 3000

CH – Swiss, Ettoy
Tel: +41 (0) 21 821 02 30
parker.switzerland@parker.com

CH – Swiss, Otelfingen
Parker Origa AG
Tel +41 44 846 6860
info-hoch-sales@parker-origa.com

CN – China, Shanghai
Tel: +86 21 5031 2525

CZ – Czechia, Klecany
Tel: +420 284 083 111
parker.czechrepublic@parker.com

DE – Germany, Kaarst
Tel: +49 (0)2131 4016 0
parker.germany@parker.com

DK – Denmark, Ballerup
Tel: +45 43 56 04 00
parker.denmark@parker.com

ES – Spain, Madrid
Tel: +34 902 33 00 01
parker.spain@parker.com

FI – Finland, Vantaa
Tel: +358 (0)20 753 2500
parker.finland@parker.com

FR – France
Tel: +33 (0)4 50 25 80 25
parker.france@parker.com

FR – France, Courtaboeuf Cedex
Parker Origa SAS
Tel +33 1 69 29 22 00
info-hofr-sales@parker-origa.com

GR – Greece, Atenas
Tel: +30 210 933 6450
parker.greece@parker.com

HK – Hong Kong
Tel: +852 2428 8008

HU – Hungary, Budapest
Tel: +36 1 220 4155
parker.hungary@parker.com

IE – Ireland, Dublin
Tel: +353 (0)1 466 6370
parker.ireland@parker.com

IN – India, Mumbai
Tel: +91 22 6513 7081-85

IT – Italy, Corsico (MI)
Tel: +39 02 45 19 21
parker.italy@parker.com

IT – Italy, Pioltello (MI)
Parker Origa SRL
Tel +39 02 92 16 65 53
info-hoit-sales@parker-origa.com

JP – Japan, Fujisawa
Tel: +(81) 4 6635 3050

KR – Korea, Seúl
Tel: +82 2 559 0400

KZ – Kazakhstan, Almaty
Tel: +7 7272 505 800
parker.easteurope@parker.com

LV – Latvia, Riga
Tel: +371 6 745 2601
parker.latvia@parker.com

MX – Mexico, Apodaca
Tel: +52 81 8156 6000

MY – Malaysia, Subang Jaya
Tel: +60 3 5638 1476

MY – Malaysia, Penang
Parker Origa Sdn Bhd
Tel +60 4 508 10 11
info-hosg-sales@parker-origa.com

NL – Netherlands, Oldenzaal
Tel: +31 (0)541 585 000
parker.nl@parker.com

NL – Netherlands, SL Moerdijk
Parker Origa B.V.
Tel +31 168 356 600
info-honi-sales@parker-origa.com

NO – Norway, Ski
Tel: +47 64 91 10 00
parker.norway@parker.com

NO – Norway, Drammen
Parker Origa AS
Tel +47 3 288 08 40
info-hose-sales@parker-origa.com

NZ – New Zealand
Mt Wellington
Tel: +64 9 574 1744

PL – Poland, Varsovia
Tel: +48 (0)22 573 24 00
parker.poland@parker.com

PT – Portugal, Leca da Palmeira
Tel: +351 22 999 7360
parker.portugal@parker.com

RO – Romania, Bucarest
Tel: +40 21 252 1382
parker.romania@parker.com

RU – Russia, Moscow
Tel: +7 495 645-2156
parker.hungary@parker.com

SE – Sweden, Spånga
Tel: +46 (0)8 59 79 50 00
parker.sweden@parker.com

SE – Sweden, Kungsör
Parker Origa AB
Tel +46 227 411 00
info-hose-sales@parker-origa.com

SG – Singapor
Tel: +65 6887 6300

SG – Singapor
Parker Origa PTE Ltd.
Tel: +65 6483 2959
info-hose-sales@parker-origa.com

SK – Slovakia, Banská Bystrica
Tel: +421 484 162 252
parker.slovakia@parker.com

SI – Slovenia, Novo Mesto
Tel: +386 7 337 6650
parker.slovenia@parker.com

TH – Thailand, Bangkok
Tel: +662 717 8140

TR – Turkey, Istanbul
Tel: +90 216 4997081
parker.turkey@parker.com

TW – Taiwan, Taipei
Tel: +886 2 2298 8987

UA – Ukraine, Kiev
Tel +380 44 494 2731
parker.ukraine@parker.com

UK – United Kingdom, Gloucester
Parker Origa Ltd.
Tel +44 8700 600655
info-hogb-sales@parker-origa.com

UK – United Kingdom, Warwick
Tel: +44 (0)1926 317 878
parker.uk@parker.com

US – United States of America, Cleveland
Tel: +1 216 896 3000

US – United States of America
Parker Origa Corporation
Tel +1 630 871 830-0
info-hous-sales@parker-origa.com

VE – Venezuela, Caracas
Tel: +58 212 238 5422

ZA – South Africa,
Kempton Park
Tel: +27 (0)11 961 0700
parker.southafrica@parker.com

Parker-Origa GmbH

Industriestr. 8

70794 Filderstadt, Deutschland

Tel. +49 7185 17030

Fax +49 7158 64870

www.parker-origa.com