

## P33 Coalescing and Adsorber Filters – Standard

- Integral 1/2" or 3/4" ports (NPT, BSPP & BSPT)
- Removes liquid aerosols and sub micron particles
- Oil free air for critical applications, such as air gauging, pneumatic instrumentation and control
- Differential Pressure Indicator (DPI) standard on Coalescing Filters
- Positive bayonet latch to ensure correct & safe fitting
- Adsorbing activated carbon element removes oil vapors and most hydrocarbons



**Note:** To optimize the life of coalescing element, it is advisable to install a P33F pre-filter with a 5 micron element upstream of the coalescing filter.

To optimize the life of an Adsorber it is advisable to install a P33 Coalescing Filter upstream of the Adsorber. Adsorber element should be replaced approximately every 1000 hours of service.

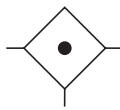

Port Size	Description †	Element	Part Number
1/2"	Poly Bowl, Manual Drain	0.01 micron	<b>P33FA14DGMN</b>
1/2"	Poly Bowl, Auto Drain	0.01 micron	<b>P33FA14DGAN</b>
1/2"	Metal Bowl, Manual Drain	0.01 micron	<b>P33FA14DSMN</b>
1/2"	Metal Bowl, Auto Drain	0.01 micron	<b>P33FA14DSAN</b>
3/4"	Poly Bowl, Manual Drain	0.01 micron	<b>P33FA16DGMN</b>
3/4"	Poly Bowl, Auto Drain	0.01 micron	<b>P33FA16DGAN</b>
3/4"	Metal Bowl, Manual Drain	0.01 micron	<b>P33FA16DSMN</b>
3/4"	Metal Bowl, Auto Drain	0.01 micron	<b>P33FA16DSAN</b>

† For polycarbonate bowl, see caution in Engineering Section A.

### Operating Information

Supply pressure (max):	
Poly bowl	150 psig (10 bar)
Metal bowl w/ DPI	150 psig (10 bar)
Metal bowl w/o DPI	250 psig (17 bar)
Operating temperature:	
Plastic bowl	-13°F to 125°F (-25°C to 52°C)
Metal bowl	-13°F to 150°F (-25°C to 65.6°C)
Standard filtration:	
	1.0 and 0.01 micron
Adsorber	
	Max. oil carryover (ppm w/w) 0.003 @ 70°F (21°C)
Flow capacity*:	
1.0 micron coalescing	68 scfm (32 dm³/s, ANR)
0.01 micron coalescing	42 scfm (20 dm³/s, ANR)
Activated carbon adsorber	72 scfm (34 dm³/s, ANR)
Useful retention†:	
	2.8 US oz. (85 cm³)
Weight:	
	1.10 lb (0.50 kg)

\* Inlet pressure 91.3 psig (6.3 bar). Pressure drop 3 psig (0.2 bar), saturated element.

† Useful retention refers to volume below the quiet zone baffle.

Air quality:ISO 8573-1:2010: 0.01µm closes to Class 1 for maximum particle size and concentration of solid contaminants, and closes to Class 1 on maximum oil content (ppm/wt).

Within ISO 8573-1:2010: Adsorber closes to Class 1 on maximum oil content (ppm/wt).

### Ordering Information:

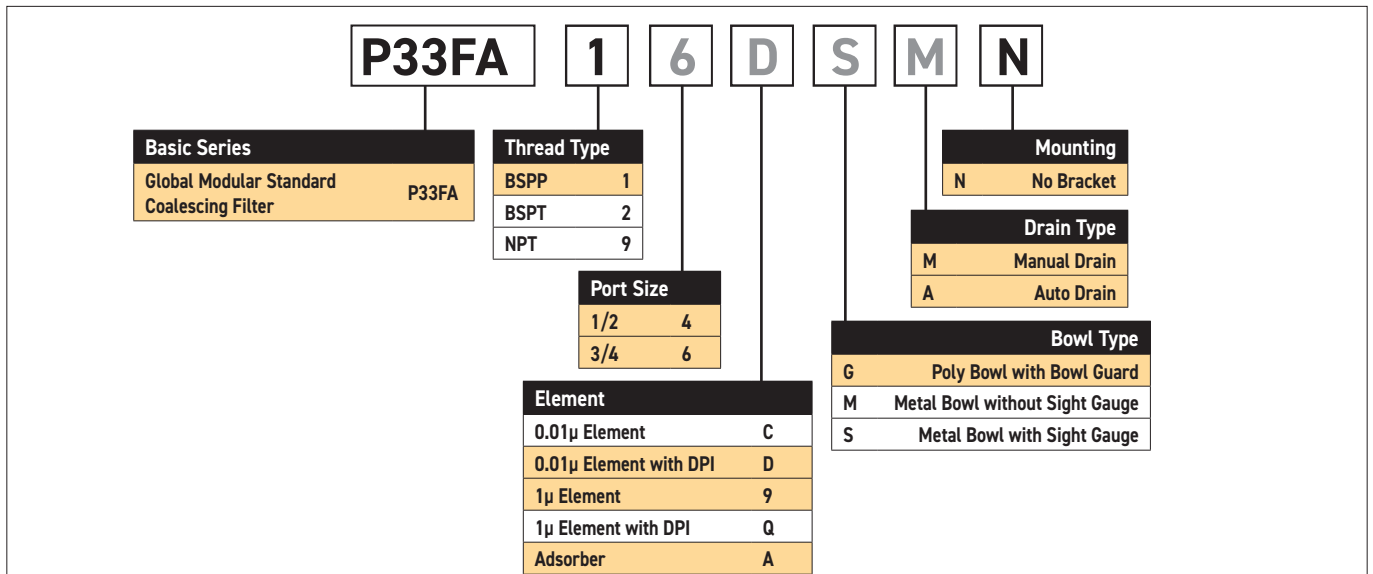

### Most Popular



**Material Specifications**

Body	Aluminum
Body cap	ABS
Plastic bowl	Polycarbonate
Metal bowl	Aluminum
Filter element	Borosilicate cloth
Adsorber	Activated carbon
Seals	Nitrile
Sight gauge	Nylon

**Repair and Service Kits**

Plastic bowl / bowl guard, manual drain	<b>P33KA00BGM</b>
Metal bowl / sight gauge, manual drain	<b>P33KA00BSM</b>
Auto drain	<b>P32KA00DA</b>
1µ coalescing filter element	<b>P33KA00ES9</b>
0.01µ coalescing filter element	<b>P33KA00ESC</b>
Activated carbon adsorber filter element	<b>P33KA00ESA</b>
L-bracket (fits to body)	<b>P33KA00ML</b>
T-bracket (fits to body connector)	<b>P32KA00MB</b>
T-bracket with body connector	<b>P32KA00MT</b>
Body connector	<b>P32KA00CB</b>
Differential pressure indicator (replacement)	<b>P32KA00RQ</b>

**Flow Charts**

**P33FA - 1.0 micron flow**

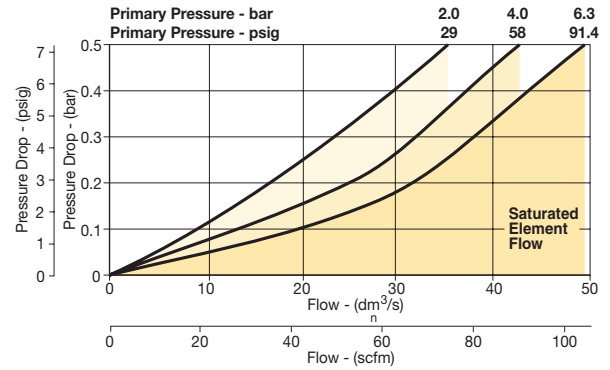

**P33FA - 0.01 micron flow**

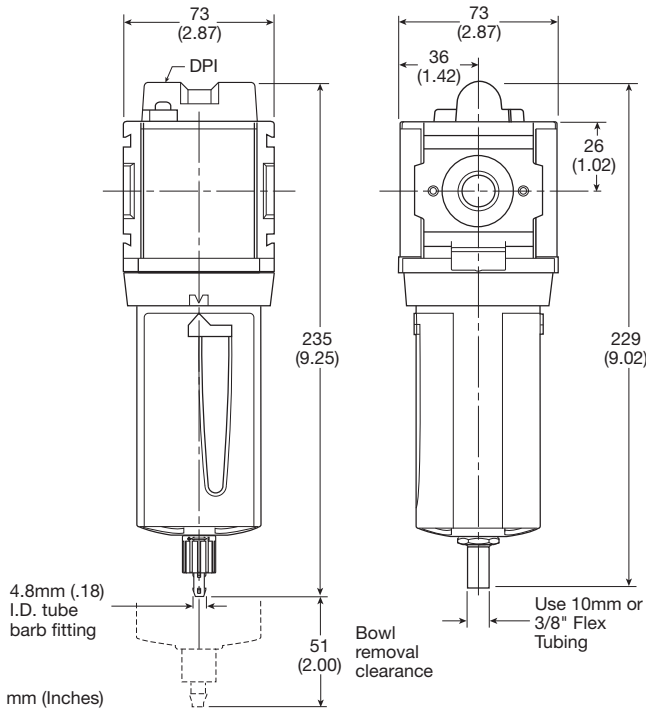
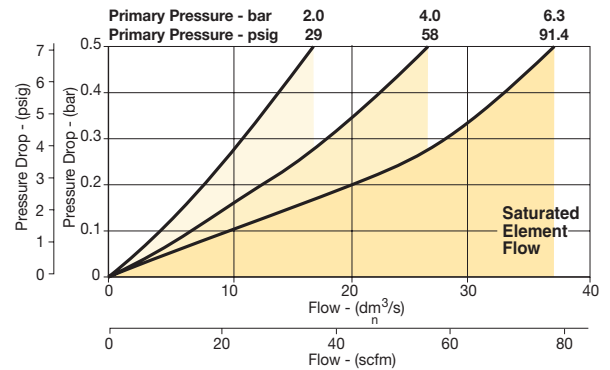

Manual Drain

Automatic Drain

**Most Popular**

