



## Valves and Valve Islands

aerospace  
climate control  
electromechanical  
filtration  
fluid & gas handling  
hydraulics  
pneumatics  
process control  
sealing & shielding



ENGINEERING YOUR SUCCESS.

## Information on application

The contents of this catalog are not binding and are only intended for informational purposes and are not to be considered as offer with legal effect. A written confirmation of order from Parker Origa is authoritative for the conclusion of a contract; this confirmation is given solely under the respective currently applicable Parker Origa General Terms of Sale and Delivery. These are included in our price list and in the Internet at [www.parker-origa.com](http://www.parker-origa.com).

All the products presented in this catalog are purely for commercial use. None of the information or contents is appropriate for private consumers. Private consumers cannot place orders based on the information in the catalog. Please contact Parker Origa for further information.

All the products listed in this catalog are designed for typical pneumatic applications which e.g. are installed in higher-level machines. The recognized technical rules for safe and expert work are to be observed for the use and installation of pneumatic products. The precondition for the use of the products is, unless stated otherwise, correctly prepared compressed air free from aggressive media. Furthermore, the respective regulations of the legislator, the TÜV (Technical Inspection Association), the respective professional associations or the VDE (Association of Electrical, Electronic and Information Technologies) provisions also apply.

The technical data stated in this catalog is to be observed by the user. The data stated may not be exceeded nor fallen short of. If such data is not stated then it may be assumed that there are no such upper or lower limits or restrictions for particular applications. In the case of unusual physical or chemical applications, consultation and clearances are to be obtained from Parker Origa.

Unless otherwise agreed in individual cases, the customer or end consumer is responsible for the disposal of the ORIGA products. Disposal by Parker Origa is not included in the price and this would have to be taken into account in the event of any applicable return to and disposal by Parker Origa.

### Technical data and representations

The technical data and illustrations have been compiled with great care and to the best of our knowledge. We cannot assume any guarantee for the up-to-dateness, correctness and completeness of the information.

The data and information such as illustrations, drawings, descriptions, dimensions, weights, materials, technical and other performances as well as the products and services described in general product descriptions, Parker Origa catalogs, brochures and price lists of any type are subject to change and may be modified or updated at any time without prior announcement by Parker Origa. They are only binding in so far as the contract or confirmation of order expressly refers to them. Slight deviations from such product descriptions are deemed as approved and do not affect the fulfillment of contracts in so far as these are considered acceptable to customers.

This catalog does not contain any guarantees, assured characteristics or agreements on condition by Parker Origa for the products represented, neither expressly nor implicitly, nor with regard to the availability of the products. Advertising statements regarding quality characteristics, properties or applications of ORIGA products are without legal obligation.

As far as legally permissible, any liability is excluded on the part of Parker Origa for direct or indirect damage, consequential damage, claims of any type and on any legal basis arising from the use of the information contained in this catalog.

### Trademarks, copyright and reproduction

The representation of industrial rights such as brands, logos, registered trademarks or patents in this catalog does not include the granting of licenses or rights of use. The use of these is not permitted without the express consent of Parker Origa. The entire contents of this catalog are the intellectual property of Parker Origa. Within the meaning of copyright, any unlawful use of intellectual property, even extracts, is prohibited. Reprinting, reproduction and translation (even extracts) are only permitted with the prior written consent of Parker Origa.

## Importance of EU Directives

Various Directives have been issued by the EU Commission in the course of the unification of the single European market; the following Directives are in part of significance for ORIGA products:

- Simple pressure vessels (87/404/EWG, amended by 90/488/EWG and 93/68/EWG)
- Low-voltage electrical equipment (73/23/EWG, amended by 93/68/EWG)
- Machinery Directive (89/392/EWG, amended by 91/368/EWG, 93/44/EWG and 98/37/EG)
- Pressure Equipment Directive (97/23/EWG)
- Equipment and protective systems intended for use in potentially explosive atmospheres (ATEX Directive, 94/9/EG)
- Electromagnetic Compatibility Directive (EMV Directive, 89/336/EWG, amended by 92/31/EWG)

If a product comes within the scope of application of one of these Guidelines, then an EU Declaration of Conformity with CE mark (CE for Communauté Européenne) is required. This CE marking does not represent a quality feature but verifies that the conformity assessment procedure specified has been concluded successfully and the protective requirements of the relevant EU Directives have been observed.

Products which do not come under any of the above mentioned Directives may not bear the CE mark nor may any manufacturer's declaration according to the EU Machinery Directive or Declaration of Conformity be issued for these products.

If a product may not be CE marked according to the Machinery Directive, it must however be marked if it comes within the scope of application of any other Directive.

The following harmonized standards are applied in the design of ORIGA components and systems:

- DIN EN ISO 12100 Safety of machinery
- DIN EN 60204.1 Electrical equipment of machines
- DIN EN 983 Safety requirements for fluid power systems and their components

### The following Directives are of particular significance to Parker Origa:

- ORIGA products in potentially explosive atmospheres, to which the above mentioned ATEX Directive applies, are treated according to the Directive and CE and EX marked.
- According to the Machinery Directive, ORIGA products are mainly components for installation in machines and therefore do not require an EU Declaration of Conformity with CE mark. Parker-ORIGA issues a manufacturer's declaration according to the Machinery Directive for these components. This declaration corresponds to a great extent to the Declaration of Conformity with the comment that commissioning is only permitted if the machine or system conforms to the Directives. This manufacturer's declaration impacts neither our product liability based on the product liability law nor warranty assurances according to our General Terms of Sale and Delivery. Neither does the manufacturer's declaration affect our quality assurance measures according to our Quality Management Manual nor our quality certification according to ISO 9001.
- According to the Pressure Equipment Directive, ORIGA products are components of low hazard potential, thus most of the products do not come under this Directive. The exceptions to this are maintenance equipment from a certain pressure/volume level onwards. These components are treated according to the Directive if required and bear the CE mark.

### ORIGA products are excluded from the following EU Guidelines:

- End-of-life vehicles (2000/53/EG).
- Waste Electronic and Electrical equipment (WEEE, 2002/96/EG) and Restriction on Hazardous Substances (RoHS, 2002/95/EG).
- Pressure Equipment Directive (97/23/EWG) with the above mentioned exceptions.

# Table of Contents



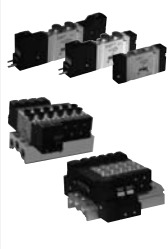







Fig.	Description	Page
	<b>Small Valves</b> 3/2 Way Valves, manually-, mechanically -, pedal actuated Series K9-G1/8 Version for Panel Mounting to DIN 43696	<b>3-9</b>
	<b>Flat Slide Valves</b> 4/3 Way Valves, manually actuated Series DRS-G1/8	<b>11-13</b>
	<b>Compact Valves</b> in Threaded version with Push-in Connections Series S10-G1/8, G1/4 3/2, 5/2, 5/3 Way Valves, pneumatic, electrically actuated RPS Manifolds and Valve Islands, Accessories	<b>15-42</b>
	<b>Way Valves</b> in Threaded version Series S9-G1/8 to G1/2 3/2, 5/2, 5/3 Way Valves, manually, pneumatically and electrically actuated Version with Logic Elements Version for Panel Mounting to DIN 43696 (only for series S9-G1/8)	<b>43-79</b>
	<b>Solenoid-Poppet Valves</b> directly actuated Series EV-M5/G1/8 3/2 Way Solenoid Poppet Valves Screw-in Version Series V9-G1/8 3/2 Way Solenoid Poppet Valves with Threaded Ports	<b>81-86</b>
	<b>Valve Islands *</b> Series IM-20, G1/8, G1/4 Version with Multipole Connection * Neutral purchase order form for valve islands see page 135	<b>87-92</b>

Fig.	Description	Page
	<b>P- Supply and RPS-Manifolds</b> for Directional Valves, Series S9-G1/8, S9-G1/4, S9-G1/2 P-Supply Manifolds Series PL-G1/8, G1/4, G1/2 RPS-Manifolds Series PL-G1/8, G1/4	<b>93-100</b>
	<b>Special Valves</b> Series S9-G1/8, S9-G1/4 3/2, 5/2, 5/3 Way Valves with NAMUR Connections Series S9-G1/8, S9-G1/4 5/2 Way Valves for Two Hand Operation 5/2 Way Oscillating Valves Series F-G1/4 3/2 and 5/2 Way Valves with pedal actuation Series ARKV-G1/2 to G2 2/2 Valve pneumatically actuated	<b>101-116</b>
	<b>Directional Valves for Base Plate Mounting</b> Series S20 5/2 and 5/3 Way Valves to VDMA 24563 Size 01 5/2 and 5/3 Way Valves to ISO 5599 Size 1, 2, 3 pneumatic, electrically actuated	<b>117-125</b>
	<b>Base Plates</b> Single Base Plates and Base Plate combinations to – VDMA 24563 Size 01 – ISO 5599 Size 1, 2, 3	<b>127-134</b>

## Way Valves to ATEX-Directives 94/9/EG ATEX95)

You will find further information on the ATEX Directives in our brochure No A5P060E



## Table of Contents

Version	Actuation	Page		
		Characteristics	Dimensions	Order Instructions Overview
3/2 Way Valves	Manual Control	4	5	9
	Mechanical	4	6	9
	Pedal	4	6	9
for panel mounting to DIN 43696	Manual Control	4	7, 8	9

# Directional Control Valves

*Series K9-G1/8*

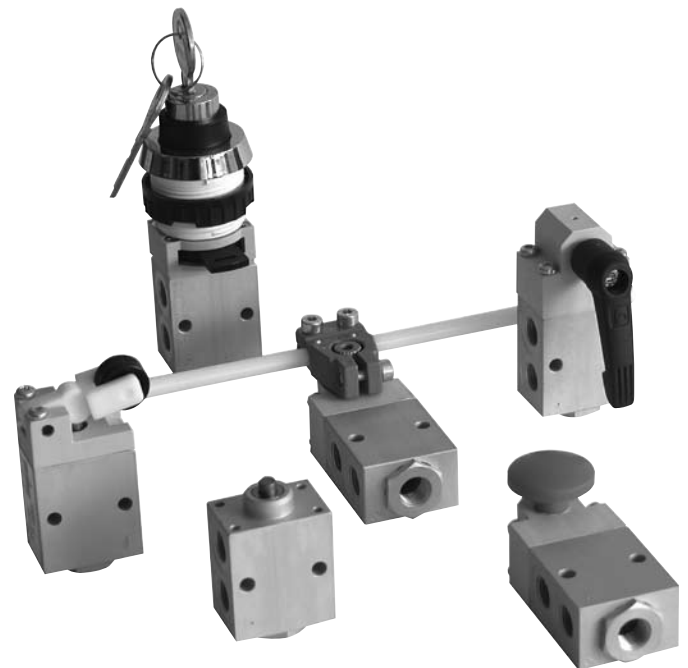

## 3/2 Way Valves

Series K9  
G1/8

### Actuation:

- Rotary lever, indexed
- Rotary lever, spring return
- Rotary lever, indexed, secured in two positions
- Pushbutton
- Cam operation
- Toggle cam operation
- Plunger operated
- Cam operated, free cam left or free cam right
- Pivoted lever
- Pedal
- Actuators for panel mounting

### Versions:

For panel mounting, actuators correspond to internationally standardized mounting dimensions to DIN 43696 (Ø22, Ø30 mm)

Non-overlapping poppet valve with low actuating force and short response time.

Applicable as normally closed or normally open valve (see drawing).

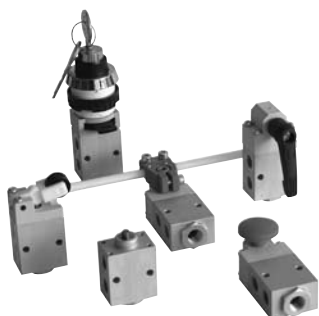

### Characteristics – Series K9

Characteristics	Symbol	Unit	Description
General Features			
System			Poppet Valve
Mounting			2 Screws M4
Tube connection			Thread
Port size			G1/8
Weight (mass)		kg	See page 4
Installation			In any position
Ambient temperature range	$T_{\min/\max}$	°C	-10 to +55
Medium temperature range	$T_{\min/\max}$	°C	+5* to +60
Medium			Filtered and lubricated or filtered and unlubricated
Lubrication			None or oil mist lubrication
Pneumatic Characteristics			
Nominal pressure	$p_n$	bar	6
Operating pressure range	$p_{\min/\max}$	bar	0 – 10
Nominal flow	QN	l/min	350
Flow direction			1 → 2 normally closed 3 → 2 normally open
Actuation			
Actuation			Manual, mechanical and pedal actuated (see page 5-8)
Stroke		mm	1.5 – 3
Actuation force	$F_b$	N	(see page 4)

\* -10°C when using dry compressed air

### Actuation Forces, Rotation Angles and Weight

Description	Type	Actuation force (N)	Rotation angle	Weight mass (kg)
Rotary lever, indexed	K9 312-1/8	4.5	±45°, 90°	0.110
Rotary lever, spring return	K9 312RF-1/8	4.5	±45°, 90°	0.110
Rotary lever, indexed secured in both positions	K9 312S-1/8	4.5	±45°, 90°	0.110
Pushbutton	K9 314RF-1/8	25	–	0.075
Cam operation	K9 321RF-1/8	11	–	0.070
Toggle cam operation	K9 324RF-1/8	5	±40°	0.120
Plunger operated	K9 323RF-1/8	32	–	0.050
Cam operated free cam left	K9 325RF-1/8	5	±40°	0.120
Cam operated free cam right	K9 326RF-1/8	5	±40°	0.120
Pivoted lever	K9 329RF-1/8	2*	±40°	0.115
Pedal	K9 331RF-1/8	12	–	0.800
Basic valve for panel mounting actuators	K9 390RF-1/8	35	–	0.060

\* at a distance of 100 mm from fulcrum

**Rotary Lever – Type: K9 312...-1/8**

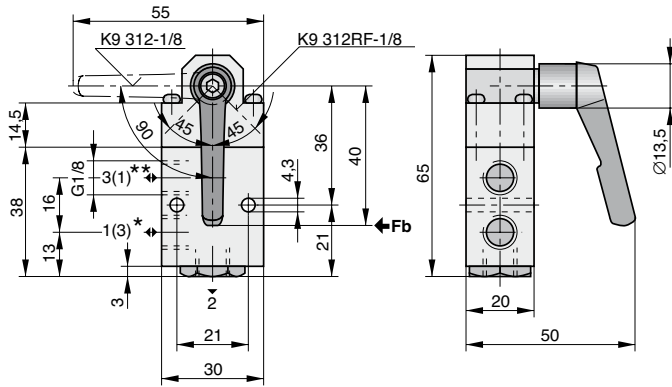

- \* = P when used as “normally closed“
- \*\* = P when used as “normally open“

**Plunger Operated – Type: K9 323RF-1/8**

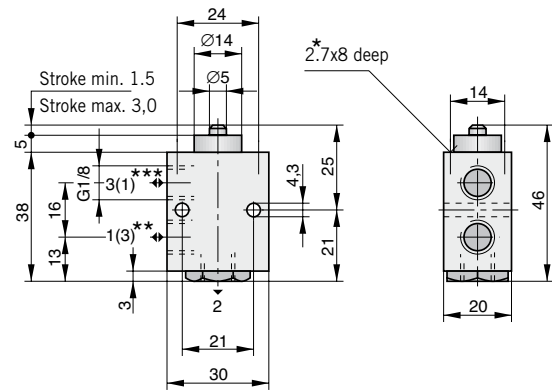

- \* Self tapping screws CM 3x.. DIN 7500 to be used
- \*\* = P when used as “normally closed“
- \*\*\* = P when used as “normally open“

**Pushbutton – Type: K9 314RF-1/8**

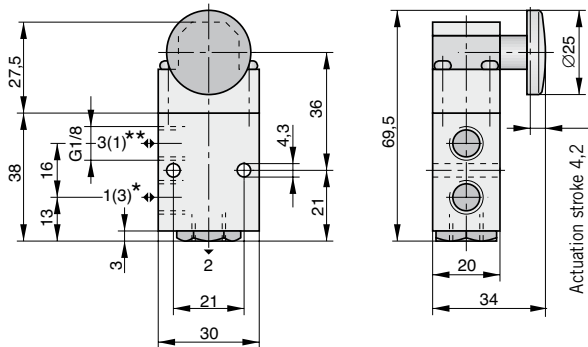

- \* = P when used as “normally closed“
- \*\* = P when used as “normally open“

**Cam operation– Type: K9 321RF-1/8**

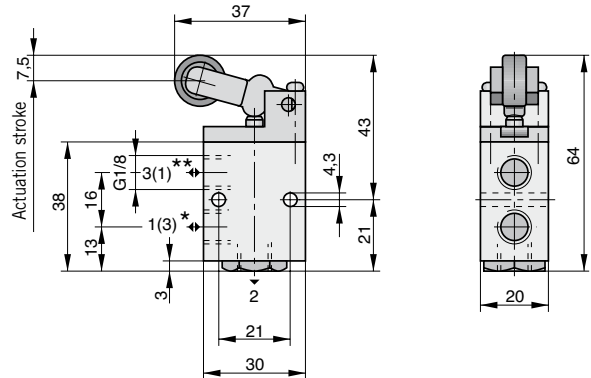

- \* = P when used as “normally closed“
- \*\* = P when used as “normally open“

Order Instructions see page 9, Characteristics see page 4

Dimensions in mm

**Toggle Cam Operation – Type: K9 324RF-1/8**

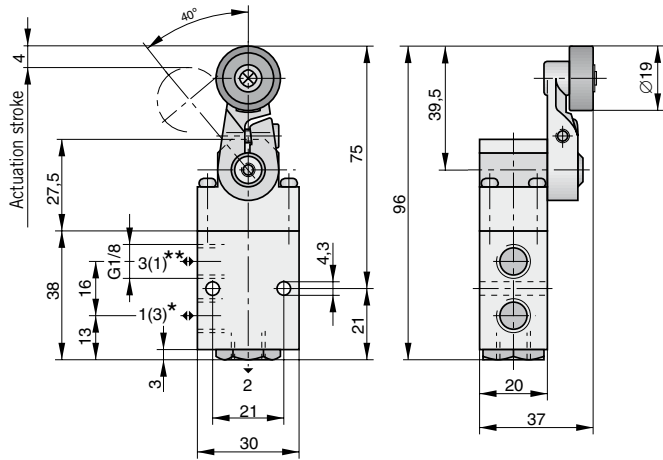

\* = P when used as “normally closed”  
 \*\* = P when used as “normally open”

**Pivoted Lever – Type: K9 329RF-1/8**

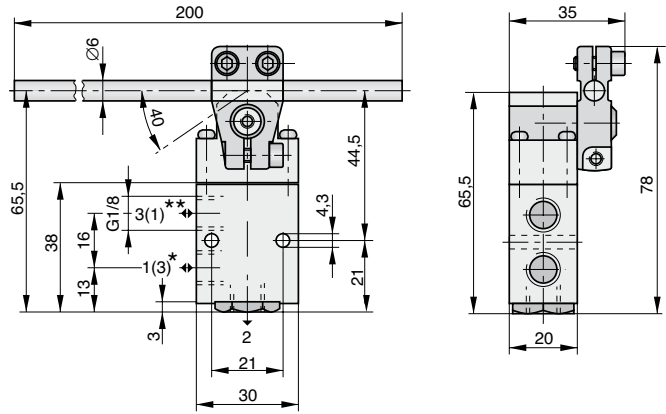

\* = P when used as “normally closed”  
 \*\* = P when used as “normally open”

**Cam Operated free cam left / right  
 Type: K9 325RF-1/8, K9 326RF-1/8**

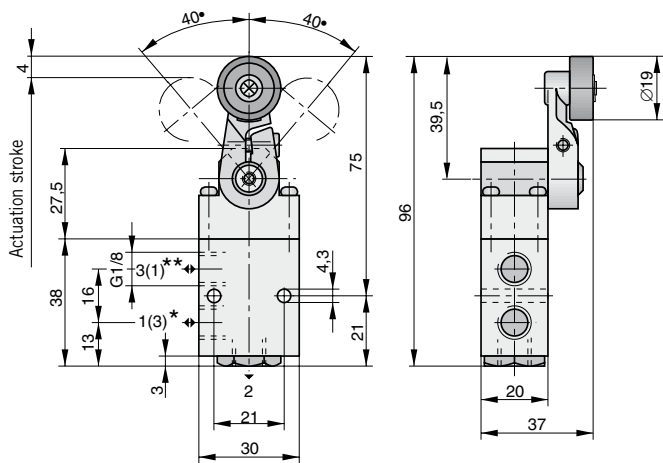

\* = P when used as “normally closed”  
 \*\* = P when used as “normally open”

**Pedal – Type: K9 331RF-1/8**

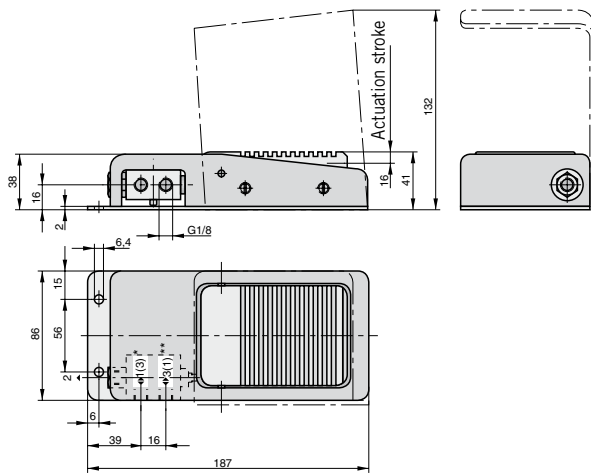

\* = P when used as “normally closed”  
 \*\* = P when used as “normally open”



**Basic Valve with adaptor for panel mounting  
Type: K9 390RF-1/8**

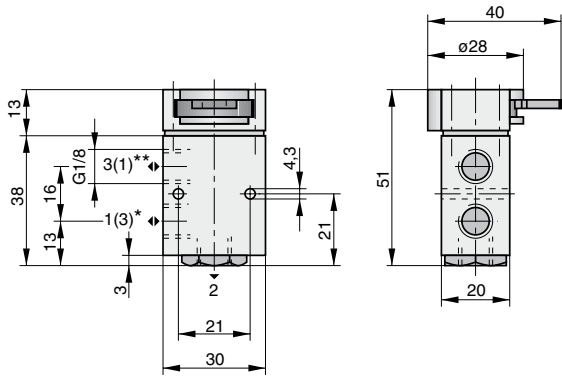

**Mounting holes for mounting diameters 22 and 30 mm**

Mounting diameter  $\varnothing 22$  mm

Mounting diameter  $\varnothing 30$  mm

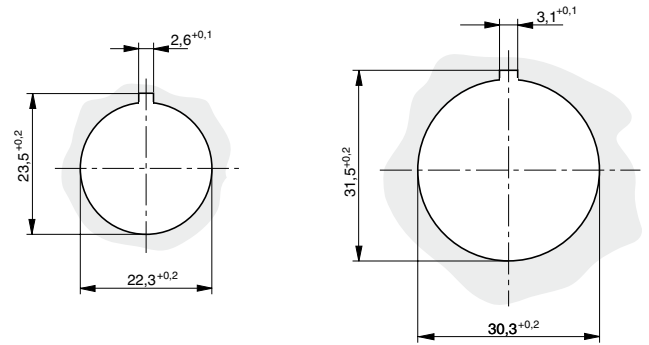

\* = P when used as “normally closed”  
\*\* = P when used as “normally open”

**Rotary Lever, indexed – Type: 12T-22, 12T-30**

Mounting diameter  $\varnothing 22$  mm

Mounting diameter  $\varnothing 30$  mm

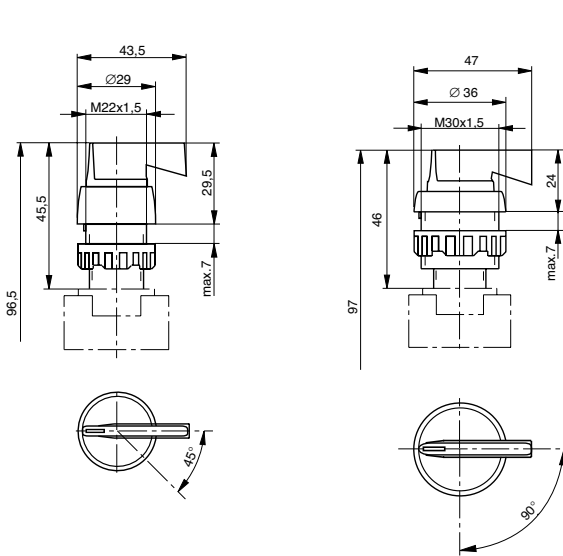

**Rotary Lever with spring return – Type: 12T-RF-22, 12T-RF-30**

Mounting diameter  $\varnothing 22$  mm

Mounting diameter  $\varnothing 30$  mm

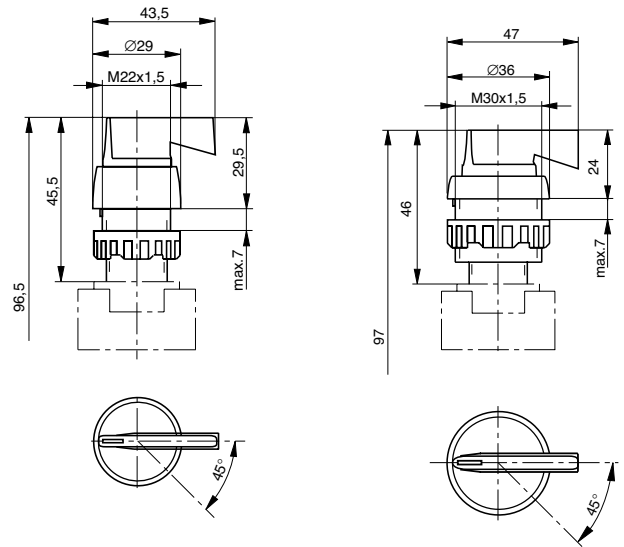

Order Instructions see page 9, Characteristics see page 4

Dimensions in mm

**Pushbutton – Type: 13T-RF-22, 13T-RF-30**

Mounting diameter  $\varnothing 22$  mm

Mounting diameter  $\varnothing 30$  mm

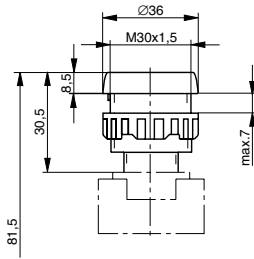
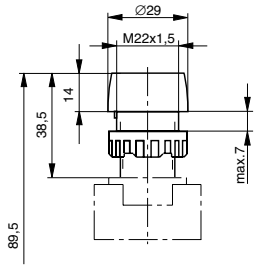

**Rotary Switch – Type: 17T-22, 17T-30**

Mounting diameter  $\varnothing 22$  mm

Mounting diameter  $\varnothing 30$  mm

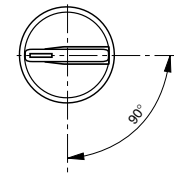
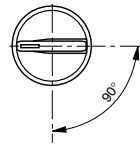
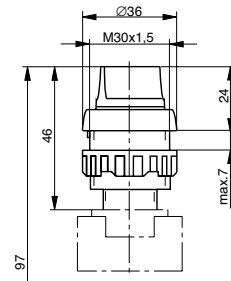
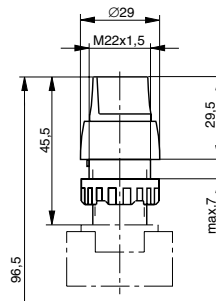

**Mushroom Pushbutton – Type: 15T-RF-22, 15T-RF-30**

Mounting diameter  $\varnothing 22$  mm

Mounting diameter  $\varnothing 30$  mm

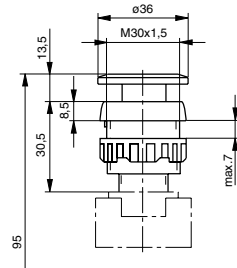
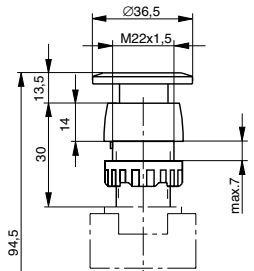

**Locking Switch – Type: 16T-22, 16T-30**

Mounting diameter  $\varnothing 22$  mm

Mounting diameter  $\varnothing 30$  mm

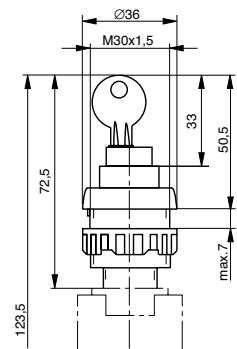
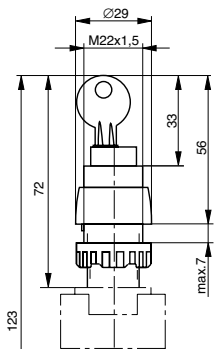

**Mushroom Switch (EMERGENCY SHUTDOWN) – Type: 18T-22, 18T-30**

Mounting diameter  $\varnothing 22$  mm



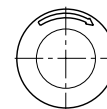
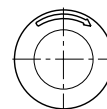
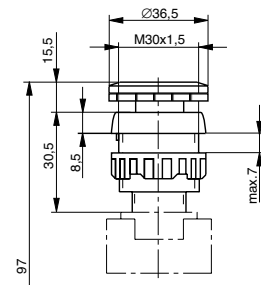
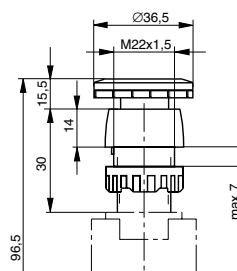





Mounting diameter  $\varnothing 30$  mm

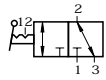
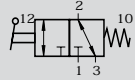
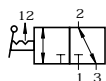
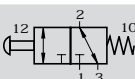
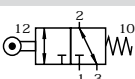
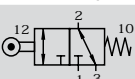
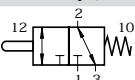
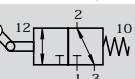
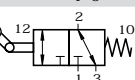
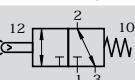
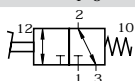
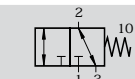

Order Instructions see page 9, Characteristics see page 4

Dimensions in mm

### Order Instructions – 3/2 Way Poppet Valves, Series K9

Actuation	Symbol	Mounting Ø (mm)	Order Instructions		Page
			Type	Order No.	
Rotary lever, indexed			K9 312-1/8	PA 10269	5
Rotary lever, spring return			K9 312RF-1/8	PA 10270	5
Rotary lever, indexed secured in both positions			K9 312S-1/8	PA 10349	5
Pushbutton			K9 314RF-1/8	PA 10271	5
Cam operation			K9 321RF-1/8	PA 10272	5
Toggle cam operation			K9 324RF-1/8	PA 10273	6
Plunger operated			K9 323RF-1/8	PA 10235	5
Cam operated free cam left			K9 325RF-1/8	PA 10274	6
Cam operated free cam right			K9 326RF-1/8	PA 10275	6
Pivoted lever			K9 329RF-1/8	PA 10276	6
Pedal			K9 331RF-1/8	PA 10277	6
Panel mounting valve with adaptor for interchangeable actuation			K9 390RF-1/8	PA 10278	7
Rotary lever, indexed		22 30	12T-22 12T-30	KX 9355 KX 9314	7
Rotary lever, spring return		22 30	12T-RF-22 12T-RF-30	KX 9356 KX 9315	7
Pushbutton		22 30	13T-RF-22 13T-RF-30	KX 9357 KX 9316	8
Mushroom pushbutton		22 30	15T-RF-22 15T-RF-30	KX 9358 KX 9317	8
Locking switch		22 30	16T-22 16T-30	KX 9359 KX 9318	8
Rotary switch		22 30	17T-22 17T-30	KX 9360 KX 9319	8
Mushroom switch EMERGENCY SHUTDOWN		22 30	18T-22 18T-30	KX 9361 KX 9320	8



## Contents

Version	Actuation	Page		
		Characteristics	Dimensions	Order Instructions Overview
4/3 Way Valves	Rotary lever	12	13	13
	Rotary switch	12	13	13

# Directional Control Valves

*Series DRS-G1/8*



# 4/3 Way Flat Slide Valves

Series DRS  
G1/8

Actuation:  
– Rotary lever  
– Rotary switch

## Characteristics – Series DRS

Characteristics	Symbol	Unit	Description
General Features			
System			Flat slide valve without automatic return to neutral position
Mounting			2 Screws M4
Tube connection			Thread
Port size			Port P, A, B: G1/8 Port R: M5
Weight (mass)		kg	0.500
Installation			In any position
Ambient temperature range	$T_{\min/\max}$	°C	-10 to +55 Note: Please consult us for operating temperatures below 0°C
Medium temperature range	$T_{\min/\max}$	°C	-10 to +60
Medium			Filtered compressed air
Lubrication			Oil mist lubrication compatible with Buna N
Pneumatic Characteristics			
Nominal pressure	$p_n$	bar	6
Operating pressure range	$p_{\min/\max}$	bar	0–10
Nominal flow	$Q_N$	l/min	350
Actuation			
Manual control			Direct
Actuation force	$F_b$	N	ca. 6



**Rotary Lever – Type: DRS 412 .-1/8**

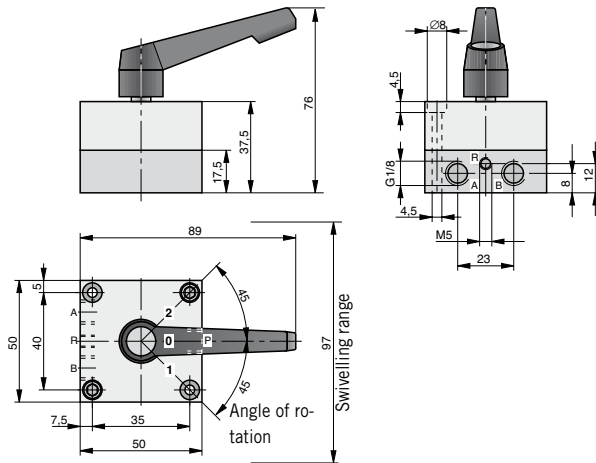

Port identification:  
 A = 4 Outlet  
 B = 2 Outlet  
 R = 5 Exhaust  
 P = 1 Pressure supply

**Rotary Switch – Type: DRS 417 .-1/8**

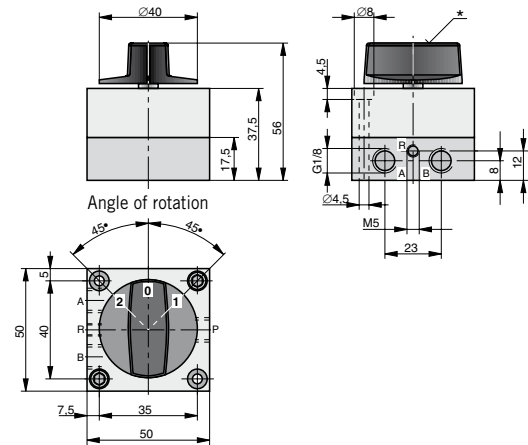

\* After removing the cover and loosening the mounting screws, the rotary switch is infinitely variable.

**Order Instructions – 4/3 Way Flat Slide Valves, Series DRS**

Actuation	Symbol	Order Instructions Type	Order No.
Rotary lever Middle position pressurized		DRS 412 B-1/8	PA 10267
Rotary lever Middle position vented		DRS 412 E-1/8	PA 10266
Rotary lever Middle position closed		DRS 412G-1/8	PA 10268
Rotary switch Middle position pressurized		DRS 417 B-1/8	PA 10264
Rotary switch Middle position vented		DRS 417 E-1/8	PA 10263
Rotary switch Middle position closed		DRS 417 G-1/8	PA 10265

Dimensions in mm





## Contents

Version	Actuation	Page		
		Characteristics	Dimensions	Order Instructions Overview
2 x 3/2 Way Valves	pneumatic	16,17	18, 20	29
	electric	16,17	19, 21	29
5/2 Way Valves	pneumatic	16,17	22, 23	30
	electric	16,17	24, 25	30
5/3 Way Valves	pneumatic	16,17	22, 23, 26, 27	31
	electric	16,17	24, 25, 28	31
Valve Manifold Assemblies		16,17	32-35	30
Valve Islands		16,17	37, 38	36
RPS-Manifolds			40	40
Accessories			41, 42	41, 42

## Compact Valves

*With threaded ports*

*Series S10..-1/8  
Series S10..-1/4*

*or  
with push-in connections*

*Series S10..-Q6  
Series S10..-Q8*

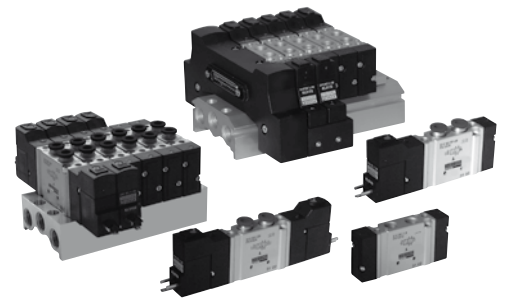

## Overview

Description	Actuation	Port		Versions			Middle Position Functions		
		G1/8 Q6	G1/4 Q8	Standard	with biased position	with external pilot air	middle position closed	middle position vented	middle position pressurized
2x3/2 Way Valves normally closed normally open	pneumatic permanent signal <sup>(1)</sup>	■	■	■	–	–	–	–	–
	electric permanent signal <sup>(1)</sup>	■	■	■	–	■	–	–	–
5/2 Way Valves	pneumatic permanent signal <sup>(2)</sup>	■	■	■	–	–	–	–	–
	pneumatic impulse	■	■	■	■	–	–	–	–
	electric permanent signal <sup>(2)</sup>	■	■	■	–	■	–	–	–
	electric impulse	■	■	■	■	■	–	–	–
5/3 Way Valves	pneumatic permanent signal	■	■	■	–	–	■	■	■
	electric permanent signal	■	■	■	–	■	■	■	■

<sup>(1)</sup> Air spring return

<sup>(2)</sup> Return by either mechanical spring or air spring (see Order Instructions, page 29-31)

### Note:

S10 Series valves are normally supplied without connector

– please include in Order Code or order separately (see Order Instructions)

**Characteristics – Series S10..-1/8, S10..-1/4, S10..-Q6, S10..-Q8 (Single Valves) and IM10 (Valve Islands)**

Characteristics	Symbol	Unit	Description	
Version			with threaded ports	with push-in connections (version Q6, Q8)
Actuation			Pneumatic	electrically pilot actuated
General Features				
System			Spool Valve	
Mounting			2 Screws M3 (S10..-1/8, S10..-Q6), 2 Screws M4 (S10..-1/4, S10..-Q8)	
Tube connection			Thread	Threaded ports and push-in connections
Port size				
– Series S10..-1/8, S10..-Q6			G1/8	Port 1, 3, 5: G1/8, Port 2, 4: push-in connection OD 6 mm
– Series S10..-1/4, S10..-Q8			Port 1, 2, 4: G1/4 Port 3, 5: G1/8	Port 1: G1/4 – Port 3, 5: G1/8 Port 2, 4: push-in connection OD 8 mm
Nominal diameter		mm	6	
Weight (mass)		kg	See page 18, 20, 22, 26	
Installation				
Ambient temperature range	$T_{min./max.}$	°C	-5 to +50	Note: for use below freezing point please consult us
Medium temperature range	$T_{min./max.}$	°C	0 to +50	
Vibration resistance / vibration		G	Max. 5	
Impact strength/shock		G	Max. 30	
Medium			Filtered compressed air (5µm)	
Lubrication			With or without oil mist lubrication (We recommend mineral oil type VG 32 to ISO 3448)	
Pneumatic Characteristics				
Nominal pressure	$p_{min./max.}$	bar	6	
Operating pressure range				
– permanent signal version	$p_{min./max.}$	bar	2 – 8 (5/2 way version), 3 – 8 (5/3 and 2x3/2 way version)	
– impulse version	$p_{min./max.}$	bar	1.5 – 8 (5/2 way version)	
– with external pilot air	$p_{min./max.}$	bar	-0.9 – 8 (5/2 way version), -0,9 – 8 (5/3 and 2x3/2 way version)	
Nominal flow				
Series – S10..-1/8, S10..-Q6	QN	l/min	5/2 way version 650, 5/3 way version 550, 2x3/2 way version 400	
Series – S10..-1/4, S10..-Q8	QN	l/min	5/2 way version 950, 5/3 way version 850, 2x3/2 way version 850	

Characteristics	Symbol	Unit	Description	
Actuation				
Pneumatic			Direct	
– actuation pressure range				
– permanent signal version	$p_{st \text{ min./max.}}$	bar	2 – 8 (5/2 way version), 3 – 8 (5/3 and 2x3/2 way version)	
– impulse version	$p_{st \text{ min./max.}}$	bar	1.5 – 8 (5/2 way version)	
Electrical single Valves S10			Electrically pilot actuated	
Voltage types			Alternating current (50/60Hz)	Direct current
Nominal voltage				
– standard version	Un	V	230, 110, 48 ±10%	24, 12 ±10% other voltages available on request
Power consumption, switching				
– standard version		VA (W)	ca. 2.8	1.1
Power consumption, holding				
– standard version		VA (W)	ca. 2	1.1
Duty cycle	ED	%	100	
Electrical protection		IP	IP 65 to DIN 40050 (applies only to solenoid with plug)	
Connection			Connector to DIN EN 175301-803 form C ( <sup>1</sup> )	
Electrical valve islands IM10			Electrically pilot actuated	
Nominal voltage	Un	V	24, 12	
Voltage types			Direct current	
Power consumption, switching			VA (W)	1.1
Power consumption, holding			VA (W)	1.1
Duty cycle	ED	%	100	
Electrical protection		IP	IP 65 to DIN 40050 (Applies only to the electrically part in combination with sub-D connector, IP 65)	
Connection			D-Sub connector 25pin	
Switching indicator			LED	
Number of outputs			max. 22, max. 18 (monostable)	

(<sup>1</sup> Solenoid also available with cable (length 1m) – see Order Instructions)

# 2 x 3/2 Way Valves Series S10

G1/8  
and  
Push-In Connections  
OD 6 mm

**Actuation systems:**  
– Pneumatic  
– Electrical pilot actuated

**Versions:**  
– 2x normally closed  
– 2x normally open  
– 1x normally closed and  
  1x normally open  
– With external pilot air

**Accessories:**  
– Adapter plate for direct  
  mounting on  
  HOERBIGER-ORIGA  
  profile-type cylinders  
– Mounting bracket

For further information see  
page 41, 42

## Weight (mass) kg

Description	Type	Weight (mass)
Pneumatic, by permanent signal	S10 361R..-1/8	0.063 kg
Electrical, by permanent signal	S10 381R..-1/8	0.089 kg
Pneumatic, by permanent signal	S10 361R..-Q6	0.070 kg
Electrical, by permanent signal	S10 381R..-Q6	0.097 kg

## 2 x 3/2 Way Valve, pneumatically actuated – threaded version Type: S10 361..-1/8

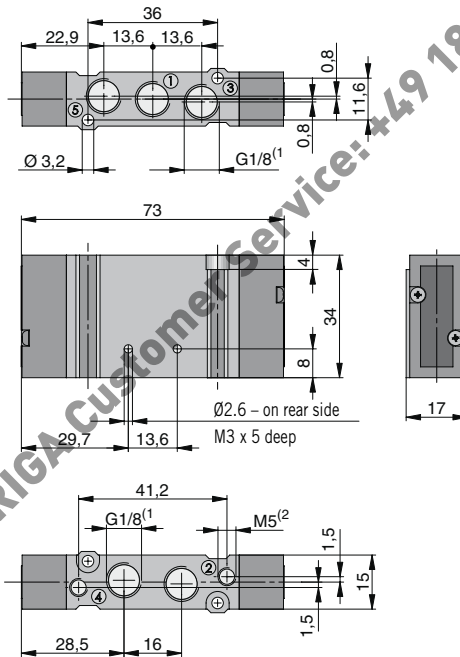

(1) thread depth 7.5 mm  
(2) thread depth 5 mm

## 2x 3/2 Way Valve, pneumatically actuated – version with push-in connection Type: S10 361..-Q6

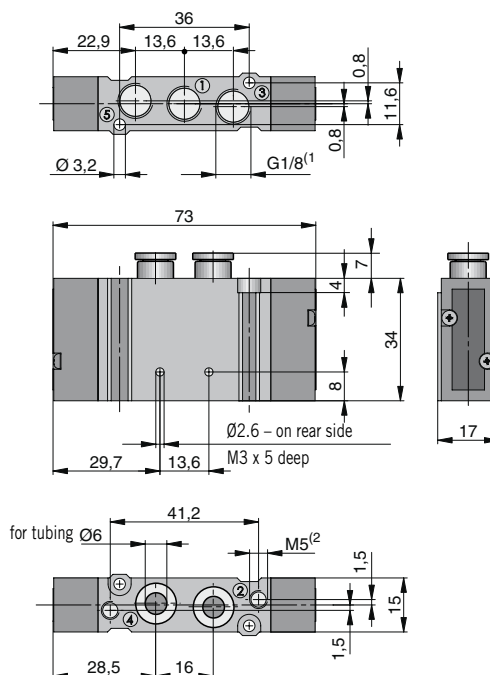

(1) thread depth 7.5 mm  
(2) thread depth 5 mm



**2 x 3/2 Way Valve, electrically actuated (permanent signal) – threaded version**  
**Type: S10 381R..-1/8**

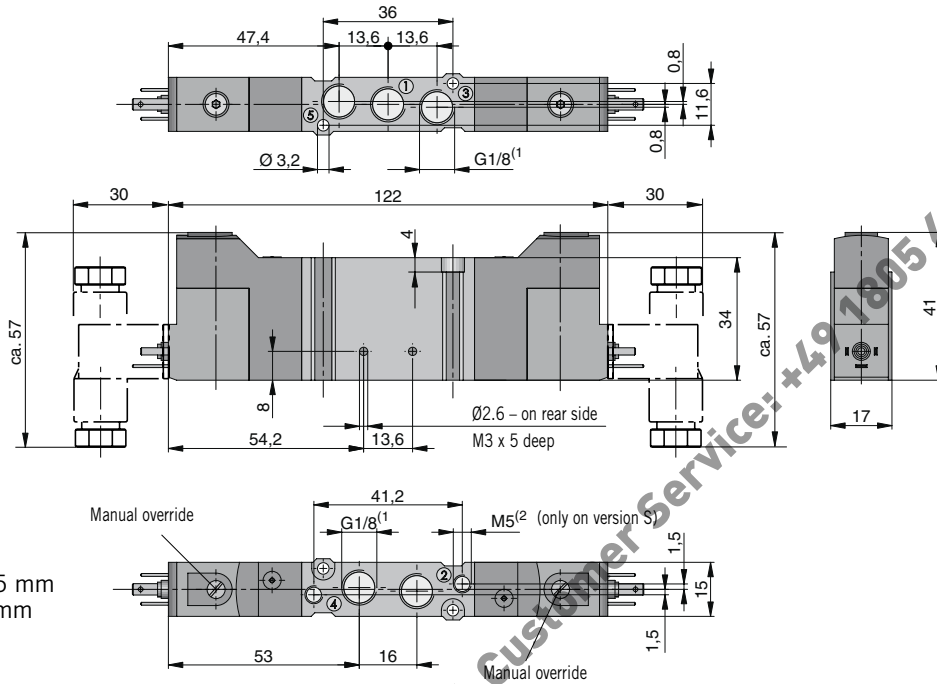

**2 x 3/2 Way Valve, electrically actuated (permanent signal) – version with push-in connections**  
**Type: S10 381R..-Q6**

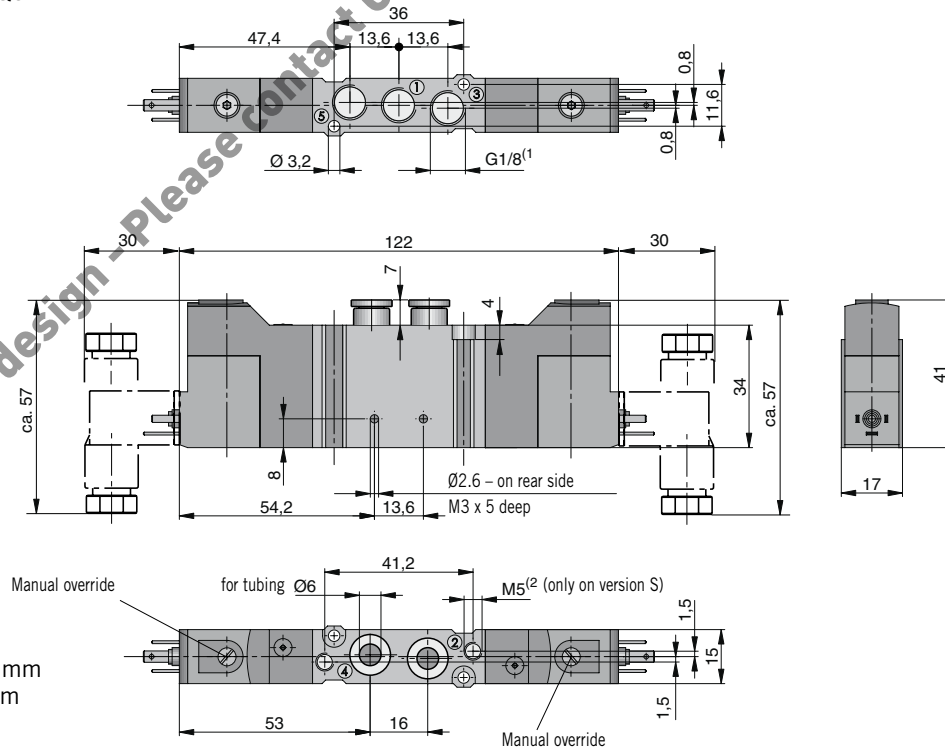

For valve manifolds see page 32-34, for RPS manifolds see page 38, for mounting bracket see page 41, for adapter plate see page 41

Dimensions in mm

# 2 x 3/2 Way Valves Series S10

G1/4  
and Push-In  
Connections  
OD 8 mm

### Actuation systems:

- Pneumatic
- Electrical pilot operated

### Versions:

- 2x normally closed
- 2x normally open
- 1x normally closed and 1x normally open
- With external pilot air

### Accessories:

- Adapter plate for direct mounting on Parker -ORIGA profile-type cylinders
- Mounting brackets

For further information see page 41, 42

### Weight (mass) kg

Description	Type	Gew. (mass)
Pneumatic, by permanent signal	S10 361R..-1/4	0.094 kg
Electrical, by permanent signal	S10 381R..-1/4	0.123 kg
Pneumatic, by permanent signal	S10 361R..-Q8	0.116 kg
Electrical, by permanent signal	S10 381R..-Q8	0.147 kg

### 2 x 3/2 Way Valve, pneumatically actuated – threaded version Type: S10 361..-1/4

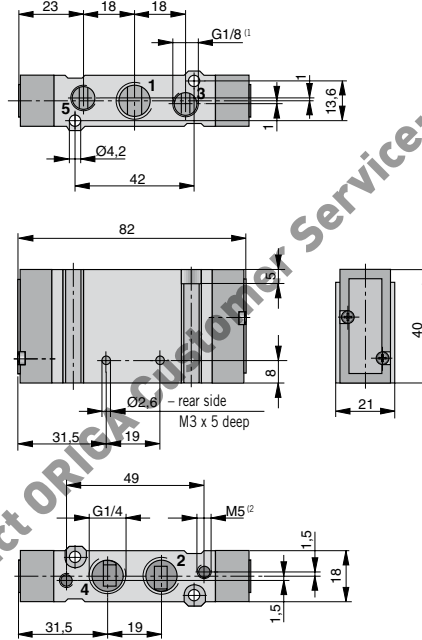

- <sup>(1)</sup> thread depth 7.5 mm  
<sup>(2)</sup> thread depth 5 mm

### 2 x 3/2 Way Valve, pneumatically actuated – version with push-in connections Type: S10 361..-Q8

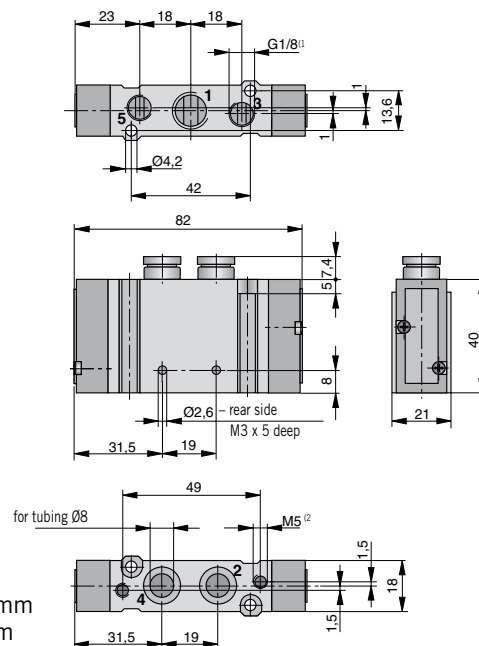

- <sup>(1)</sup> thread depth 7.5 mm  
<sup>(2)</sup> thread depth 5 mm

**2 x 3/2 Way Valve, electrically actuated (permanent signal) – threaded version**  
**Type: S10 381R..-1/4**

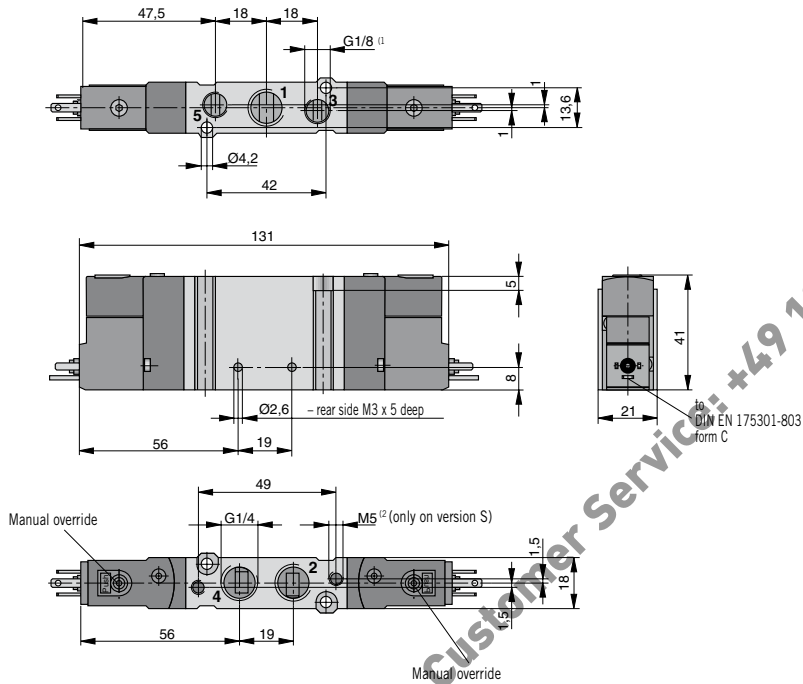

**2 x 3/2 Way Valve, electrically actuated (permanent signal) – version with push-in connections**

**Type: S10 381R..-Q8**

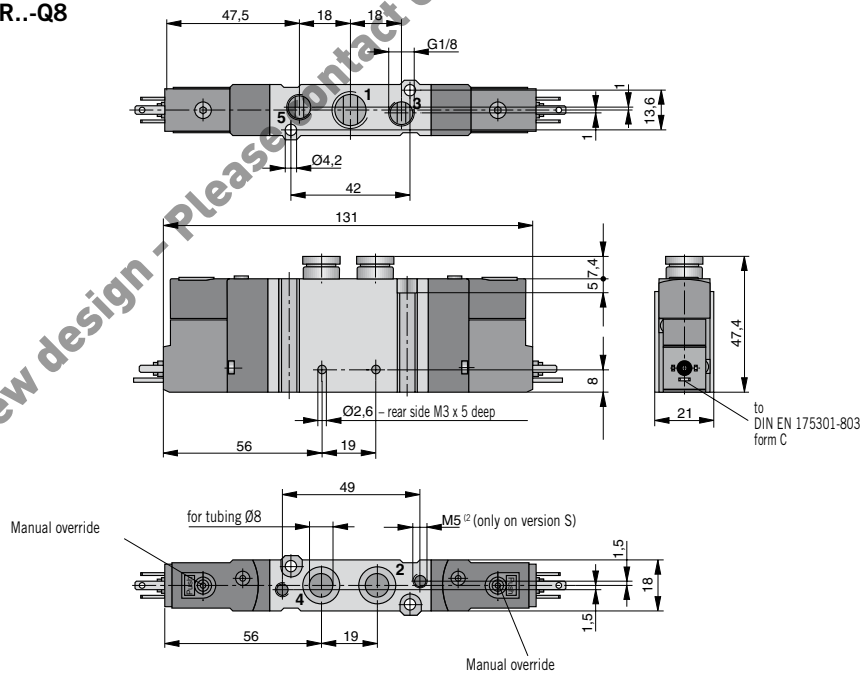

<sup>1</sup> thread depth 7.5 mm  
<sup>2</sup> thread depth 5 mm

For RPS manifolds see page Page 39, for mounting bracket see page 41,  
 for adapter plate see page 41

Dimensions in mm

# 5/2 and 5/3 Way Valves Series S10

G1/8 and  
Push-In Connections  
OD 6 mm

**Actuation systems:**  
– Pneumatic  
– Electrical, pilot operated

**Versions:**  
– With biased position  
– With external pilot air

**Accessories:**  
– Adapter plate for direct  
mounting on  
Parker -ORIGA  
profile-type cylinders  
– Mounting bracket

For further information see  
page 41, 42

## Weight (mass) kg

Description	Type	Weight (mass)
Pneumatic, by permanent signal	S10 561R..-1/8	0.063 kg
Pneumatic, by impulse	S10 561(562)-1/8	0.063 kg
Electrical, by permanent signal	S10 581R..-1/8	0.076 kg
Electrical, by impulse	S10 581(582)-1/8	0.089 kg
Pneumatic, by permanent signal	S10 561R..-Q6	0.070 kg
Pneumatic, by impulse	S10 561(562)-Q6	0.070 kg
Electrical, by permanent signal	S10 581R..-Q6	0.083 kg
Electrical, by impulse	S10 581(582)-Q6	0.097 kg

**5/2 and 5/3 Way Valve, pneumatically actuated – threaded version**  
Type: S10 561..-1/8, S10 562..-1/8, S10 561RF.-1/8

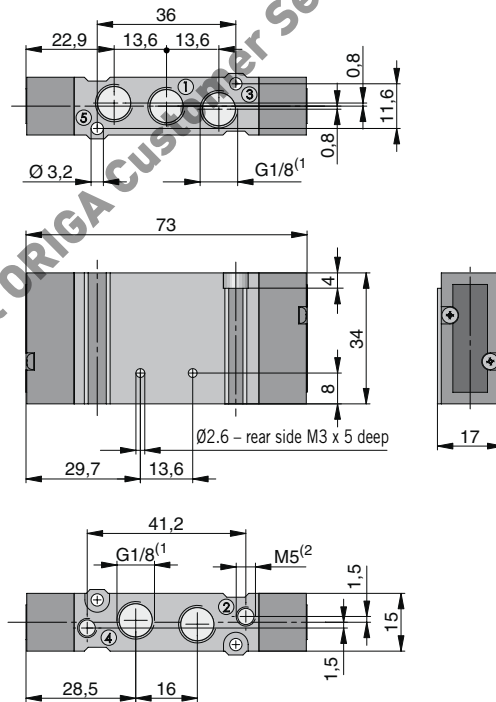

<sup>(1)</sup> thread depth 7.5 mm  
<sup>(2)</sup> thread depth 5 mm





5/2 and 5/3 Way Valve, pneumatically actuated – version with push-in connections  
 Type: S10 561..-Q6, S10 562..-Q6, S10 561RF-Q6

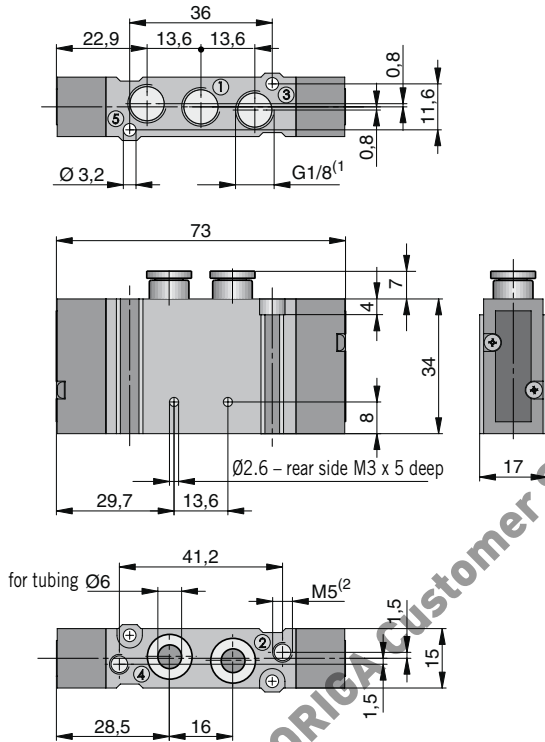

<sup>(1)</sup> thread depth 7.5 mm  
<sup>(2)</sup> thread depth 5 mm

Not for new design - Please contact ORIGA Customer Service: +49 1805 432 777

For valve manifolds see page 32-34, for RPS manifolds see page 38, for mounting bracket see page 41, for adapter plate see page 41

Dimensions in mm

**5/2 Way Valve, electrically actuated (permanent signal) – threaded version**  
**Type: S10 581...-1/8**

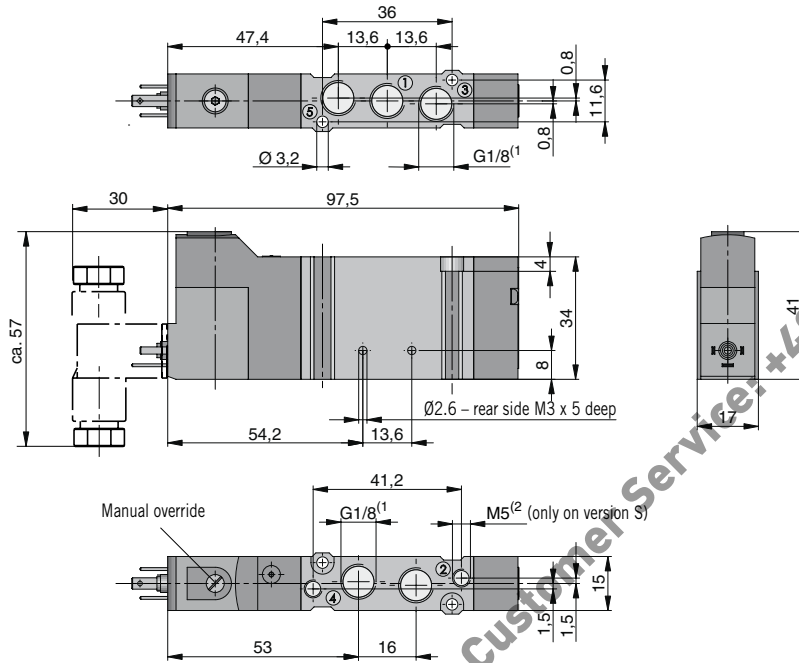

<sup>1</sup> thread depth 7.5 mm  
<sup>2</sup> thread depth 5 mm

**5/2 Way Valve, electrically actuated (permanent signal) – version with push-in connections**  
**Type: S10 581...-Q6**

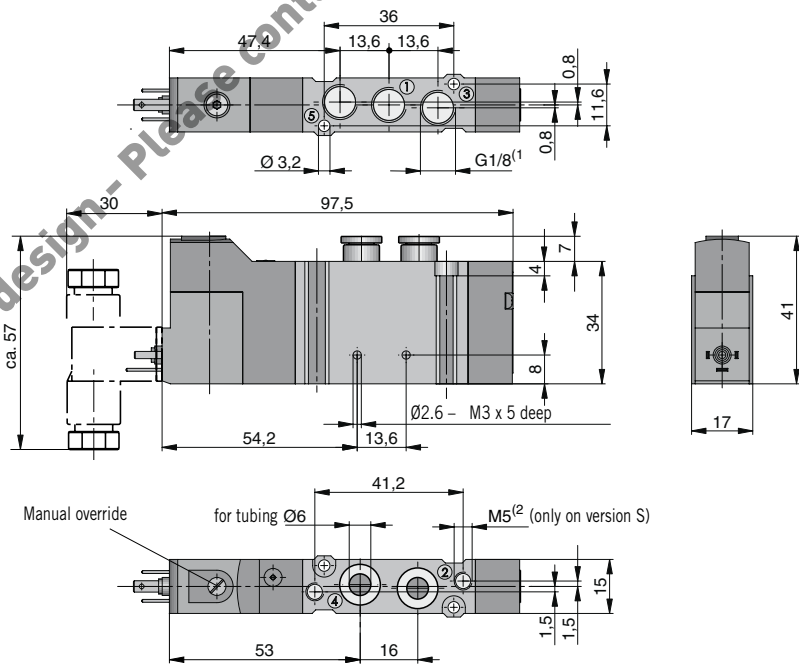

<sup>1</sup> thread depth 7.5 mm  
<sup>2</sup> thread depth 5 mm

For valve manifolds see page 32-34, for RPS manifolds see page 38, for mounting bracket see page 41,  
 for adapter plate see page 41

Dimensions in mm

5/2 Way Valve, electrically actuated (impulse) – threaded version, Type: S10 581-1/8, S10 582-1/8  
 5/3 Way Valve, electrically actuated (permanent signal) – threaded version, Type: S10 581RF-1/8

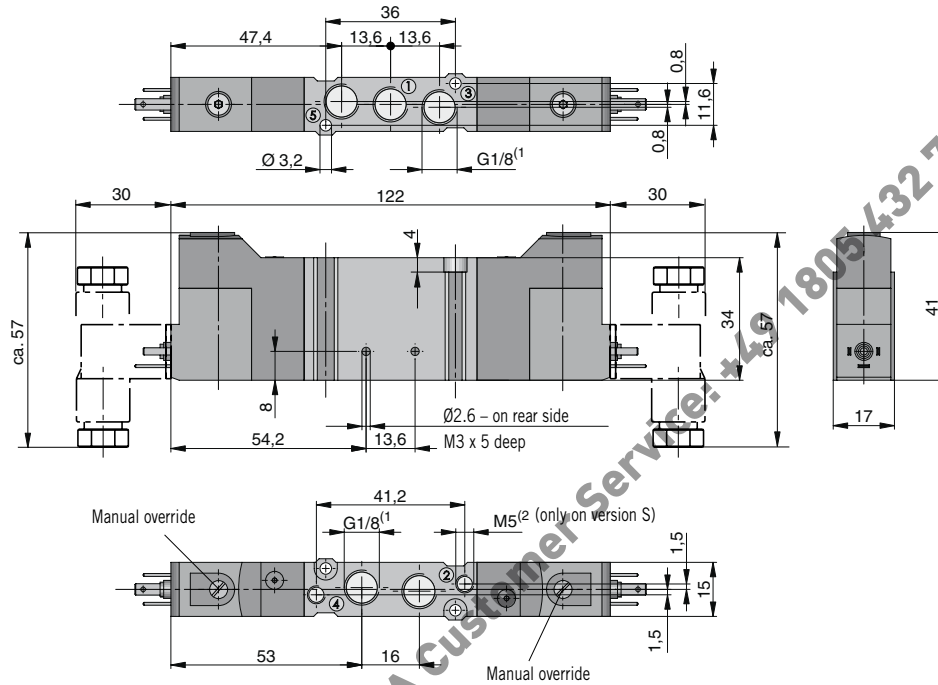

<sup>1</sup> thread depth 7.5 mm  
<sup>2</sup> thread depth 5 mm

5/2 Way Valve, electrically actuated (impulse) – version with push-in connections, Type: S10 581-Q6, S10 582-Q6  
 5/3 Way Valve, electrically actuated (permanent signal) – version with push-in connections, Type: S10 581RF-Q6

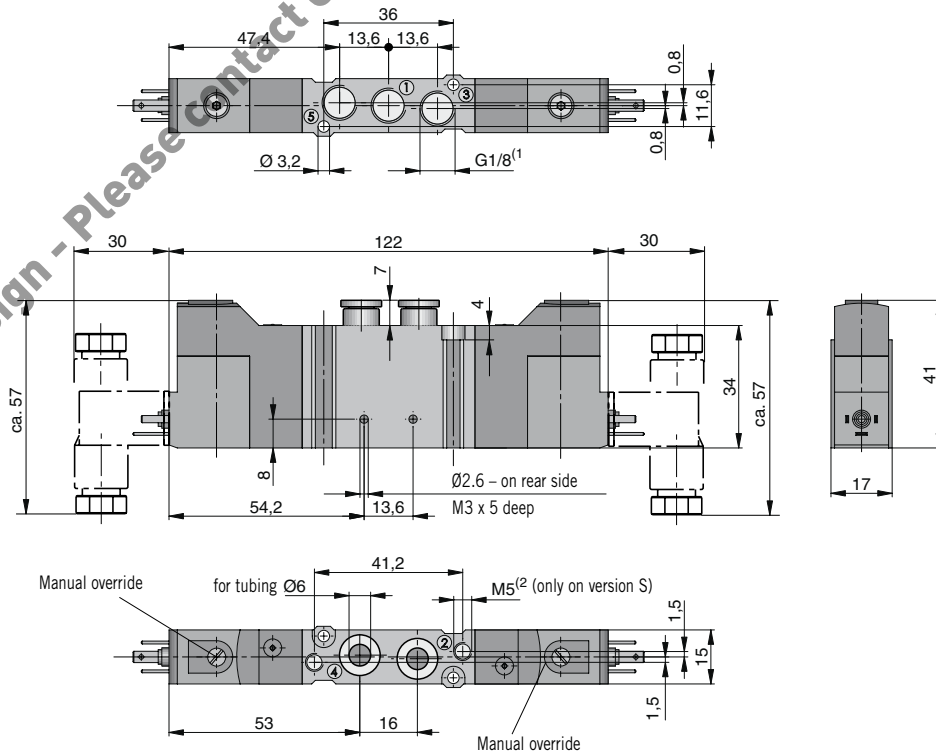

<sup>1</sup> thread depth 7.5 mm  
<sup>2</sup> thread depth 5 mm

For valve manifolds see page 32, 34, for RPS manifolds see page 38, for mounting bracket see page 41,  
 for adapter plate see page 41

Dimensions in mm

# 5/2 and 5/3 Way Valves Series S10

G1/4 and Push-In Connections OD 8 mm

- Actuation systems:  
 - Pneumatic  
 - Electrical pilot actuated

- Versions:  
 - With biased position  
 - With external pilot air

- Accessories:  
 - Adapter plate for direct mounting on Parker Origa profile-type cylinders  
 - Mounting bracket

For further information see page 41, 42

## Weight (mass) kg

Description	Type	Weight (mass)
Pneumatic, by permanent signal	S10 561R..-1/4	0.097 kg
Pneumatic, by impulse	S10 561(562)-1/4	0.097 kg
Electrical, by permanent signal	S10 581R..-1/4	0.110 kg
Electrical, by impulse	S10 581(582)-1/4	0.125 kg
Pneumatic, by permanent signal	S10 561R..-Q8	0.118 kg
Pneumatic, by impulse	S10 561(562)-Q8	0.118 kg
Electrical, by permanent signal	S10 581R..-Q8	0.132 kg
Electrical, by impulse	S10 581(582)-Q8	0.147 kg

**5/2 and 5/3 Way Valve, pneumatically actuated, threaded version**  
 Type: S10 561..-1/4, S10 562..-1/4, S10 561RF..-1/4

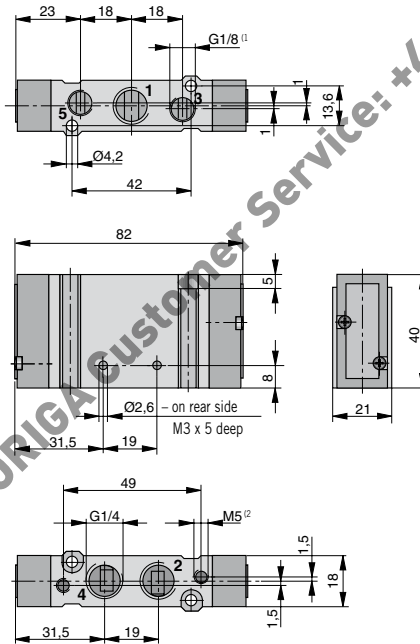

<sup>1</sup> thread depth 7.5 mm  
<sup>2</sup> thread depth 5 mm

**5/2 and 5/3 Way Valve, pneumatically actuated, version with push-in connections**  
 Type: S10 561...-Q8, S10 562...-Q8, S10 561RF.-Q8

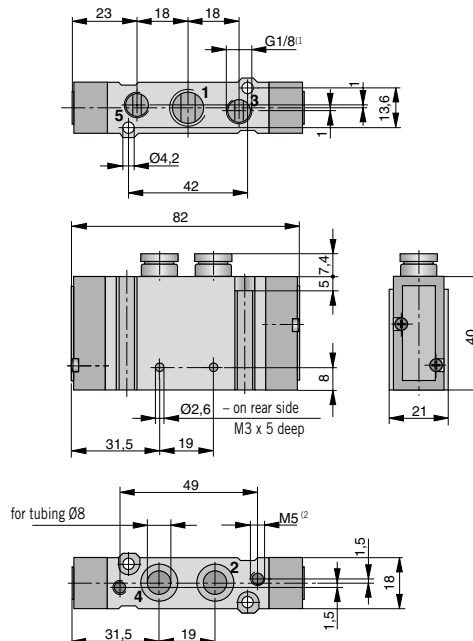

<sup>1</sup> thread depth 7.5 mm  
<sup>2</sup> thread depth 5 mm

**5/2 Way Valve, electrically actuated (permanent signal) – threaded version**  
**Type: S10 581...-1/4**

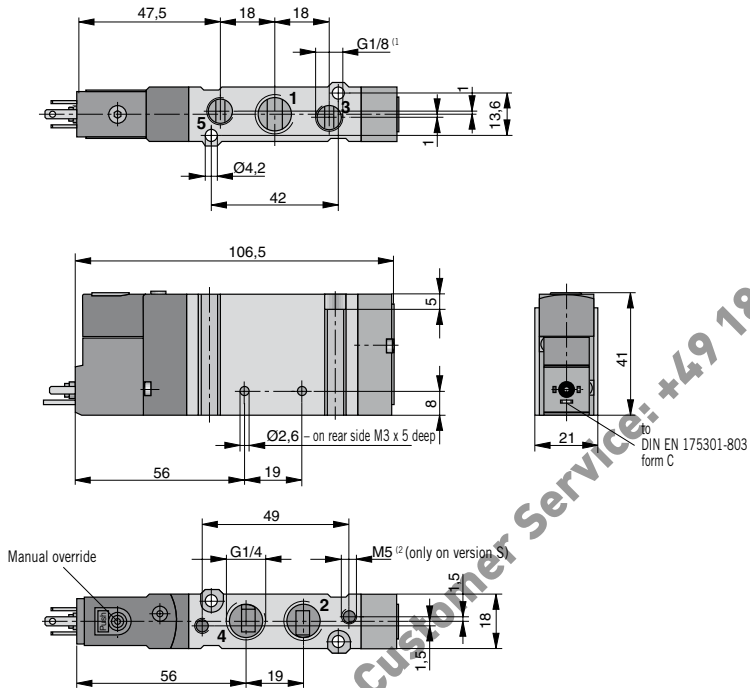

<sup>1</sup> thread depth 7.5 mm  
<sup>2</sup> thread depth 5 mm

**5/2 Way Valve, electrically actuated (permanent signal) – version with push-in connections**  
**Type: S10 581...-Q8**

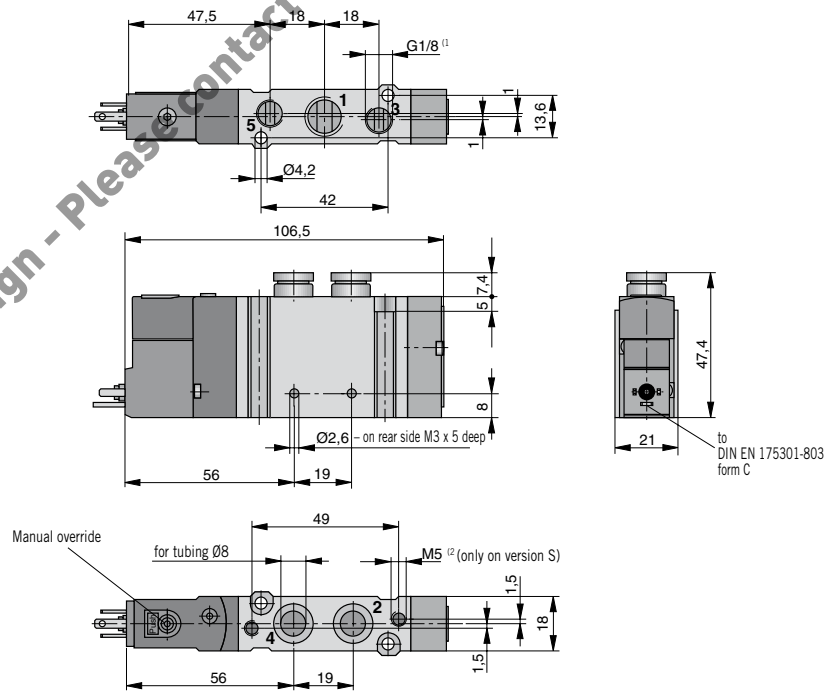

<sup>1</sup> thread depth 7.5 mm  
<sup>2</sup> thread depth 5 mm

For RPS manifolds see page 39, for mounting bracket see page 41,  
 for adapter plate see page 41

Dimensions in mm

5/2 Way Valve, electrically actuated (impulse) – threaded version Type: S10 581-1/4, S10 582-1/4  
 5/3 Way Valve, electrically actuated (permanent signal) – threaded version Type: S10 581RF-1/4

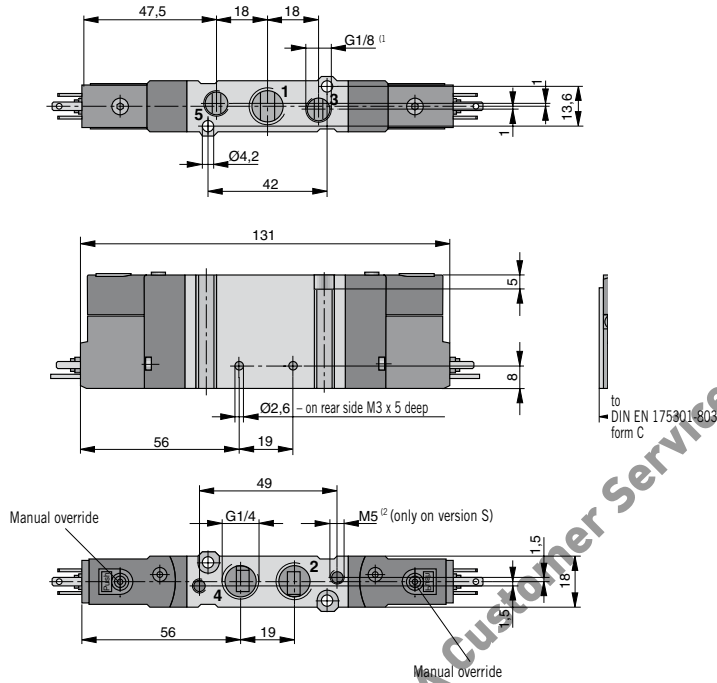

(1) thread depth 7.5 mm  
 (2) thread depth 5 mm

5/2 Way Valve, electrically actuated (impulse) – version with Push-In Connections Type: S10 581-Q6, S10 582-Q8  
 5/3 Way Valve, electrically actuated (permanent signal) – version with Push-In Connections Type: S10 581RF-Q8

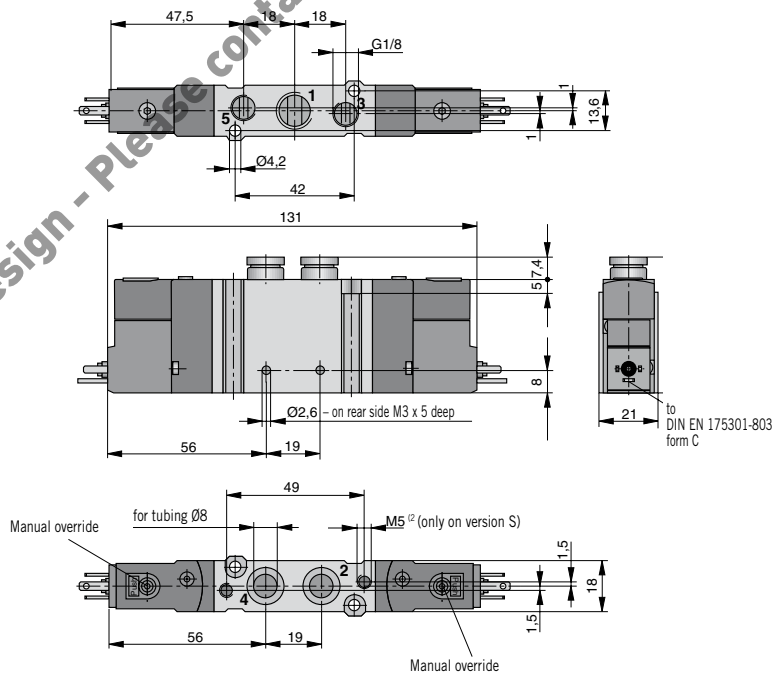

(1) thread depth 7.5 mm  
 (2) thread depth 5 mm

For RPS manifolds see page 39, for mounting bracket see page 41,  
 for adapter plate see page 41

Dimensions in mm

**Order Instructions – 2 x 3/2 Way Valves, Series S10..-1/8, S10..-1/4, S10..-Q6, S10..-Q8**

Actuation System	Symbol	Connections		Order Instructions		Page
		Thread	Push-In	Type	Order No.	
Pneumatic by permanent signal		G1/8	–	S10361R2G-1/8	PA 10417	18
		–	ODØ 6mm	S10361R2G-Q6	PA 10447	18
		G1/4	–	S10361R2G-1/4	PA 10537	22
		–	ODØ 8mm	S10361R2G-Q8	PA 10567	23
		G1/8	–	S10361R20-1/8	PA 10418	18
		–	ODØ 6mm	S10361R20-Q6	PA 10448	18
		G1/4	–	S10361R20-1/4	PA 10538	22
		–	ODØ 8mm	S10361R20-Q8	PA 10568	23
		G1/8	–	S10361RGO-1/8	PA 10419	20
		–	ODØ 6mm	S10361RGO-Q6	PA 10449	18
		G1/4	–	S10361RGO-1/4	PA 10539	22
		–	ODØ 8mm	S10361RGO-Q8	PA 10569	23
Electrical by permanent signal		G1/8	–	S10381R2G-1/8-□33-□	PA 10404-□33-□	19
		–	ODØ 6mm	S10381R2G-Q6-□33-□	PA 10434-□33-□	19
		G1/4	–	S10381R2G-1/4-□33-□	PA 10524-□33-□	21
		–	ODØ 8mm	S10381R2G-Q8-□33-□	PA 10554-□33-□	21
		G1/8	–	S10381R20-1/8-□33-□	PA 10406-□33-□	19
		–	ODØ 6mm	S10381R20-Q6-□33-□	PA 10436-□33-□	19
		G1/4	–	S10381R20-1/4-□33-□	PA 10526-□33-□	21
		–	ODØ 6mm	S10381R20-Q8-□33-□	PA 10556-□33-□	21
		G1/8	–	S10381RGO-1/8-□33-□	PA 10408-□33-□	19
		–	ODØ 6mm	S10381RGO-Q6-□33-□	PA 10438-□33-□	19
		G1/4	–	S10381RGO-1/4-□33-□	PA 10528-□33-□	21
		–	ODØ 8mm	S10381RGO-Q8-□33-□	PA 10558-□33-□	21
Electrical by permanent signal with external pilot air		G1/8	–	S10381S-R2G-1/8-□33-□	PA 10405-□33-□	19
		–	ODØ 6mm	S10381S-R2G-Q6-□33-□	PA 10435-□33-□	19
		G1/4	–	S10381S-R2G-1/4-□33-□	PA 10525-□33-□	21
		–	ODØ 8mm	S10381S-R2G-Q8-□33-□	PA 10555-□33-□	21
		G1/8	–	S10381S-R20-1/8-□33-□	PA 10407-□33-□	19
		–	ODØ 6mm	S10381S-R20-Q6-□33-□	PA 10437-□33-□	19
		G1/4	–	S10381S-R20-1/4-□33-□	PA 10527-□33-□	21
		–	ODØ 8mm	S10381S-R20-Q8-□33-□	PA 10557-□33-□	21
		G1/8	–	S10381S-RGO-1/8-□33-□	PA 10409-□33-□	19
		–	ODØ 6mm	S10381S-RGO-Q6-□33-□	PA 10439-□33-□	19
		G1/4	–	S10381S-RGO-1/4-□33-□	PA 10529-□33-□	21
		–	ODØ 6mm	S10381S-RGO-Q8-□33-□	PA 10559-□33-□	21

Solenoid version/ voltage
– for connector
00 without solenoid
01 12 VDC
02 24 VDC
04 48 VDC
07 110 VDC
50 12 VAC
51 24 VAC
55 48 VAC
57 110 VAC
61 230 VAC
– with cable (length 1m)
41 12 VDC
42 24 VDC
71 12 VAC
72 24 VAC

Other voltages available on request

**Notes on ordering:**

All electrically actuated valves are supplied **without** connector as standard.

– **please include this in Order No. or order it separately (see Order Instructions).**

For electrically actuated valves please complete the Type Designation and Order No. with the order codes.

**Example:**

3/2 Way Valve, threaded version G1/8, electrically actuated, with spring return, normally closed, voltage 12 V DC, with standard connector

**Order Instructions:**

**S10381R2G-1/8-0133-88**

**PA 10404-0133-88**

**Variants  
connector**

00 without connector *
88 standard connector 15mm
89 230 VAC with LED and protective circuit
92 24 VDC with LED and protective circuit

\* Standard version

**Order Instructions – 5/2 Way Valves, Series S10..-1/8, S10..-1/4, S10..-Q6, S10..-Q8**

Actuation System	Symbol	Connections		Order Instructions		Page
		Thread	Push-In Connections	Type	Order No.	
Pneumatic by permanent signal		G1/8	–	S10 561RF-1/8	PA 10410	22, 23
		–	ODØ 6mm	S10 561RF-Q6	PA 10440	22, 23
		G1/4	–	S10 561RF-1/4	PA 10530	26
		–	ODØ 8mm	S10 561RF-Q8	PA 10560	26
		G1/8	–	S10 561R-1/8	PA 10411	22, 23
		–	ODØ 6mm	S10 561R-Q6	PA 10441	22, 23
Pneumatic by impulse		G1/4	–	S10 561R-1/4	PA 10531	26
		–	ODØ 8mm	S10 561R-Q8	PA 10561	26
		G1/8	–	S10 561-1/8	PA 10412	22, 23
		–	ODØ 6mm	S10 561-Q6	PA 10442	22, 23
		G1/4	–	S10 561-1/4	PA 10532	26
		–	ODØ 8mm	S10 561-Q8	PA 10562	26
– with biased position		G1/8	–	S10 562-1/8	PA 10413	22, 23
		–	ODØ 6mm	S10 562-Q6	PA 10443	22, 23
		G1/4	–	S10 562-1/4	PA 10533	26
		–	ODØ 8mm	S10 562-Q4	PA 10563	26
		G1/8	–	S10 581RF-1/8-□33-□	PA 10390-□33-□	24
		–	ODØ 6mm	S10 581RF-Q6-□33-□	PA 10420-□33-□	24
Electrical by permanent signal		G1/4	–	S10 581RF-1/4-□33-□	PA 10510-□33-□	27
		–	ODØ 8mm	S10 581RF-Q8-□33-□	PA 10540-□33-□	27
		G1/8	–	S10 581R-1/8-□33-□	PA 10392-□33-□	24
		–	ODØ 6mm	S10 581R-Q6-□33-□	PA 10422-□33-□	24
		G1/4	–	S10 581R-1/4-□33-□	PA 10512-□33-□	27
		–	ODØ 8mm	S10 581R-Q8-□33-□	PA 10542-□33-□	27
Electrical by permanent signal with external pilot air		G1/8	–	S10 581S-RF-1/8-□33-□	PA 10391-□33-□	24
		–	ODØ 6mm	S10 581S-RF-Q6-□33-□	PA 10421-□33-□	24
		G1/4	–	S10 581S-RF-1/4-□33-□	PA 10511-□33-□	27
		–	ODØ 8mm	S10 581S-RF-Q8-□33-□	PA 10541-□33-□	27
		G1/8	–	S10 581S-R-1/8-□33-□	PA 10393-□33-□	24
		–	ODØ 6mm	S10 581S-R-Q6-□33-□	PA 10423-□33-□	24
Electrical by impulse		G1/4	–	S10 581S-R-1/4-□33-□	PA 10513-□33-□	27
		–	ODØ 8mm	S10 581S-R-Q8-□33-□	PA 10543-□33-□	27
		G1/8	–	S10 581-1/8-□33-□	PA 10394-□33-□	25
		–	ODØ 6mm	S10 581-Q6-□33-□	PA 10424-□33-□	25
		G1/4	–	S10 581-1/4-□33-□	PA 10514-□33-□	27
		–	ODØ 8mm	S10 581-Q8-□33-□	PA 10544-□33-□	27
– with biased position		G1/8	–	S10 582-1/8-□33-□	PA 10396-□33-□	25
		–	ODØ 6mm	S10 582-Q6-□33-□	PA 10426-□33-□	25
		G1/4	–	S10 582-1/4-□33-□	PA 10516-□33-□	27
		–	ODØ 8mm	S10 582-Q8-□33-□	PA 10546-□33-□	27
		G1/8	–	S10 581S-1/8-□33-□	PA 10395-□33-□	25
		–	ODØ 6mm	S10 581S-Q6-□33-□	PA 10425-□33-□	25
Electrical by impulse with external pilot air		G1/4	–	S10 581S-1/4-□33-□	PA 10515-□33-□	27
		–	ODØ 8mm	S10 581S-Q8-□33-□	PA 10545-□33-□	27
		G1/8	–	S10 582S-1/8-□33-□	PA 10397-□33-□	25
		–	ODØ 6mm	S10 582S-Q6-□33-□	PA 10427-□33-□	25
		G1/4	–	S10 582S-1/4-□33-□	PA 10517-□33-□	27
		–	ODØ 8mm	S10 582S-Q8-□33-□	PA 10547-□33-□	27

Supplements on types and order no. see page 29

**Notes on ordering:**

All electrically actuated valves are supplied **without** connector as standard.

– **please include this in Order No. or order it separately (see Order Instructions).**

For electrically actuated valves please complete the Type Designation and Order No. with the order codes.

**Example:**

5/2 Way Valve, Push-In Connections, electrically actuated, with spring return, voltage 24 V DC, with standard connector.

**Order Instructions:**

**S10 581RF-Q6-0233-88**

**PA 10420-0233-88**



**Order Instructions – 5/3 Way Valves, Series S10...-1/8, S10...-1/4, S10...-Q6, S10...-Q8**

Actuation System	Symbol	Connections		Order Instructions		Page
		Thread	Push-In	Type	Order No.	
Pneumatic permanent signal		G1/8	–	S10 561RFG-1/8	PA 10414	23
		–	ODØ 6mm	S10 561RFG-Q6	PA 10444	23
		G1/4	–	S10 561RFG-1/4	PA 10534	26
		–	ODØ 8mm	S10 561RFG-Q8	PA 10564	26
		G1/8	–	S10 561RFE-1/8	PA 10415	23
		–	ODØ 6mm	S10 561RFE-Q6	PA 10445	23
		G1/4	–	S10 561RFE-1/4	PA 10535	26
		–	ODØ 8mm	S10 561RFE-Q8	PA 10565	26
		G1/8	–	S10 561RFB-1/8	PA 10416	23
		–	ODØ 6mm	S10 561RFB-Q6	PA 10446	23
		G1/4	–	S10 561RFB-1/4	PA 10536	26
		–	ODØ 8mm	S10 561RFB-Q8	PA 10566	26
Electrical permanent signal		G1/8	–	S10 581RFG-1/8-□33-□	PA 10398-□33-□	25
		–	ODØ 6mm	S10 581RFG-Q6-□33-□	PA 10428-□33-□	25
		G1/4	–	S10 581RFG-1/4-□33-□	PA 10518-□33-□	28
		–	ODØ 8mm	S10 581RFG-Q8-□33-□	PA 10548-□33-□	28
		G1/8	–	S10 581RFE-1/8-□33-□	PA 10400-□33-□	25
		–	ODØ 6mm	S10 581RFE-Q6-□33-□	PA 10430-□33-□	25
		G1/4	–	S10 581RFE-1/4-□33-□	PA 10520-□33-□	28
		–	ODØ 8mm	S10 581RFE-Q8-□33-□	PA 10550-□33-□	28
		G1/8	–	S10 581RFB-1/8-□33-□	PA 10402-□33-□	25
		–	ODØ 6mm	S10 581RFB-Q6-□33-□	PA 10432-□33-□	25
		G1/4	–	S10 581RFB-1/4-□33-□	PA 10522-□33-□	28
		–	ODØ 8mm	S10 581RFB-Q8-□33-□	PA 10552-□33-□	28
Electrical permanent signal with external pilot air		G1/8	–	S10 581S-RFG-1/8-□33-□	PA 10399-□33-□	25
		–	ODØ 6mm	S10 581S-RFG-Q6-□33-□	PA 10429-□33-□	25
		G1/4	–	S10 581S-RFG-1/4-□33-□	PA 10519-□33-□	28
		–	ODØ 8mm	S10 581S-RFG-Q8-□33-□	PA 10549-□33-□	28
		G1/8	–	S10 581S-RFE-1/8-□33-□	PA 10401-□33-□	25
		–	ODØ 6mm	S10 581S-RFE-Q6-□33-□	PA 10431-□33-□	25
		G1/4	–	S10 581S-RFE-1/4-□33-□	PA 10521-□33-□	28
		–	ODØ 8mm	S10 581S-RFE-Q8-□33-□	PA 10551-□33-□	28
		G1/8	–	S10 581S-RFB-1/8-□33-□	PA 10403-□33-□	25
		–	ODØ 6mm	S10 581S-RFB-Q6-□33-□	PA 10433-□33-□	25
		G1/4	–	S10 581S-RFB-1/4-□33-□	PA 10523-□33-□	28
		–	ODØ 8mm	S10 581S-RFB-Q8-□33-□	PA 10553-□33-□	28

Solenoid version/ voltage
– for connector
00 without solenoid
01 12 VDC
02 24 VDC
04 48 VDC
07 110 VDC
50 12 VAC
51 24 VAC
55 48 VAC
57 110 VAC
61 230 VAC
– with cable (length 1m)
41 12 VDC
42 24 VDC
71 12 VAC
72 24 VAC

Other voltages available on request

**Notes on ordering:**

all electrically actuated valves are supplied **without** connector as standard  
 – **please include this in Order No. or order it separately (see Order Instructions).**

For electrically actuated valves please complete the Type Designation and Order No. with the order codes.

**Example:**

5/3 Way Valve, middle position closed, Push-In Connections, electrically actuated, with spring return, voltage 230V AC, without connector.

**Order Instructions:**

**S10 581RFG-Q6-6133-00**

**PA 10428-6133-00**

**Variants connector**

00 without connector *
88 standard connector 15mm
89 230 V AC with LED and protective circuit
92 24 VDC with LED and protective circuit

\* Standard version

# Valve Manifold Assemblies Series S10

G1/8

fully assembled

Actuation systems:

- Pneumatic
- Electrical pilot actuated

Valve Manifold assembly, fully assembled – threaded version, Type: S10-1/8-...

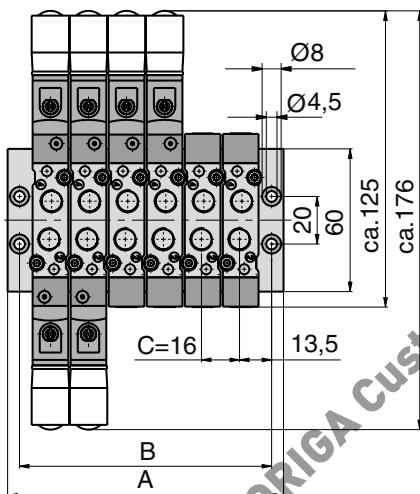
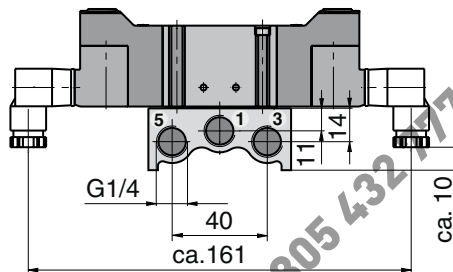
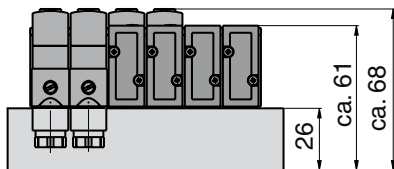

Drawing shows:  
6-fold valve manifold S10-1/8-06, 24VDC  
Order No. PA10385-06-0233-00  
Valve positions: JJMM33

Dimension Table (mm)

Dimension	Number of valves							
	2	4	6	8	10	12	14	16
A	52	84	116	148	180	212	244	276
B	42	74	106	138	170	202	234	266

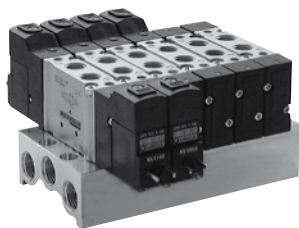

For single valves see page 18-28, for order instructions see page 36

Dimensions in mm

Valve Manifold assembly, fully assembled – version with Push-In Connections, Type: S10-Q6-..

## Valve Manifold Assembly Series S10

Push-In Connections  
OD 6 mm

fully assembled

Actuation systems:

- Pneumatic
- Electrical pilot actuated

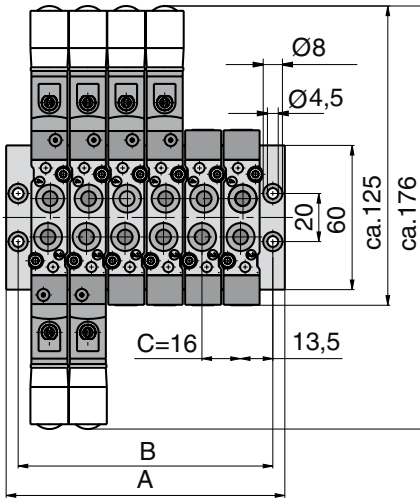
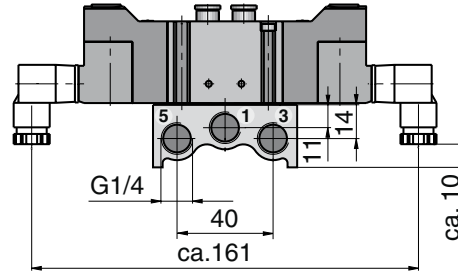
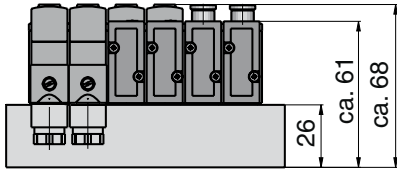

Drawing shows:  
6-fold valve manifold S10-Q6-06, 24VDC  
Order No. PA10386-06-0233-00  
Valve positions: JJMM33

Dimension Table (mm)

Dimension	Number of valves							
	2	4	6	8	10	12	14	16
A	52	84	116	148	180	212	244	276
B	42	74	106	138	170	202	234	266

For single valves see page 18-28, for order instructions see page 36

Dimensions in mm

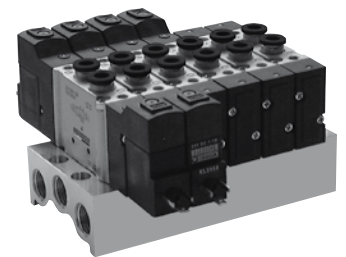

### Order Instructions – Valve Manifold Assemblies

Order No.										
P	A									
		-	-	3	3			-		
		Number of valves	Solenoid version voltage					Connector		

Version	Description
PA 10385	Valves with threaded ports G1/8 Series: S10-1/8
PA 10386	Valves with push-in ports OD 6 Series: S10-Q6

Number of Valves	Description
02	1 – 2 valves
04	3 – 4 valves
06	5 – 6 valves
08	7 – 8 valves
10	9 – 10 valves
12	11 – 12 valves
14	13 – 14 valves
16	15 – 16 valves

Solenoid version/voltage	Description
00	without solenoid
01	12 V DC
02	24 V DC
04	48 V DC
07	110 V DC
50	12 V AC
51	24 V AC
55	48 V AC
57	110 V AC
61	230 V AC
– with cable (length 1m)	
41	12 V DC
42	24 V DC
71	12 V AC
72	24 V AC
Other solenoid versions (voltages) available on request	

Connector Version	Description
00	without connector (standard version)
88	standard connector 15 mm wide
89	230 V AC with LED and protective circuit
92	24 V DC with LED and protective circuit

Valve positions																	
Valve positions 1-16																Flow divider at valve position	
1	2	3	4	5	6	7	8	9	10	11	12	13	14	15	16		
02	04	06	08	10	12	14	16										Flow divider
																(for dual pressure operating) none (standard) .. at valve position	

**Only even numbers of valves are possible!**  
Please enter the codes for the valve types required.

Order Codes for Valves and Cover Plates		
Code	Description	Page
A	Cover plate for unused valve position	41
P	Intermediate air supply adapter G1/8	41
Pneumatically actuated		
8	2x3/2 Way Valve NC, air spring return	18, 22
9	2x3/2 Way Valve NO, air spring return	18, 22
0	2x3/2 Way Valve NC, NO, air spring return	18, 22
1	5/2 Way Valve, spring return	22, 23, 26, 27
2	5/2 Way Valve, air spring return	22, 23, 26, 27
3	5/2 Way Valve, impulse	22, 23, 26, 27
4	5/2 Way Valve, impulse, with biased position	22, 23, 26, 27
5	5/3 Way Valve, middle position closed, spring return to middle position	22, 23, 26, 27
7	5/3 Way Valve, middle position exhausted, spring return to middle position	22, 23, 26, 27
6	5/3 Way Valve, middle position pressurized, spring return to middle position	22, 23, 26, 27

Order Codes for Valves and Cover Plates		
Code	Description	Page
Electrically actuated		
K	2x3/2 Way Valve NC, air spring return	19, 21
N	2x3/2 Way Valve NO, air spring return	19, 21
H	2x3/2 Way Valve NC, NO, air spring return	19, 21
M	5/2 Way Valve, spring return	24, 27
L	5/2 Way Valve, air spring return	24, 27
J	5/2 Way Valve, impulse	24, 27
D	5/2 Way Valve, impulse, with biased position	24, 27
G	5/3 Way Valve, middle position closed, spring return to middle position	25, 28
E	5/3 Way Valve, middle position exhausted, spring return to middle position	25, 28
B	5/3 Way Valve, middle position pressurized, spring return to middle position	25, 28

Order Codes for Valves and Cover Plates		
Code	Description	Page
Electrically actuated, with external pilot air		
X	2x3/2 Way Valve NC, air spring return	19, 21
Y	2x3/2 Way Valve NO, air spring return	19, 21
Z	2x3/2 Way Valve NC, NO, air spring return	19, 21
F	5/2 Way Valve, spring return	24, 27
R	5/2 Way Valve, air spring return	24, 27
S	5/2 Way Valve, impulse	24, 27
T	5/2 Way Valve, impulse, with biased position	24, 27
U	5/3 Way Valve, middle position closed, spring return to middle position	25, 28
W	5/3 Way Valve, middle position exhausted, spring return to middle position	25, 28
V	5/3 Way Valve, middle position pressurized, spring return to middle position	25, 28

Valve Islands, fully assembled – threaded version, Type: IM10-1/8-..

# Valve Islands Series IM10

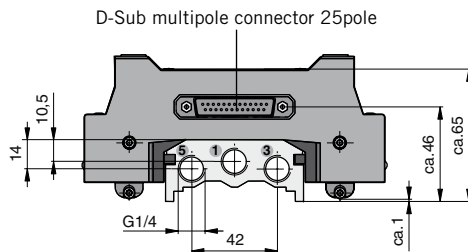
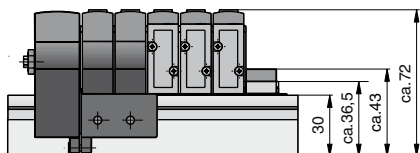

G1/8

fully assembled

Actuation systems:  
– Electrical pilot actuated

Version:  
Multipole version with D-Sub multipole connector 25pole.

Valve positions:  
– Combination mono-/bistable outputs  
max. 22  
max. 18 (monostable)

On request:  
Expandable with external field bus components (Profi Bus DP, Inter Bus S, CAN Device net, AS-Interface)

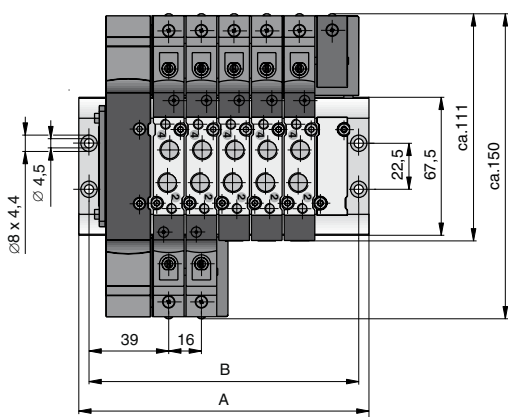

Drawing shows:  
6fold valve manifold IM10-1/8-06, 24VDC  
Order No. PA10490-06-22  
Valve positions: JJMMMC

Dimension Table (mm)

Dimension	Number of valves																	
	2	3	4	5	6	7	8	9	10	11	12	13	14	15	16	17	18	
A	78	94	110	126	142	158	174	190	206	222	238	254	270	286	302	318	334	
B	68	84	100	116	132	148	164	180	196	212	228	244	260	276	292	308	324	

For single valves see page 18-28, for order instructions see page 39

Dimensions in mm



# Valve Islands Series IM10

Valve Islands, fully assembled – with Push-In Connections, Type: IM10-Q6-..

Push-In Connections  
OD 6 mm

fully assembled

Actuation systems:  
– Electrical pilot actuated

Version:  
Multipole version with  
D-Sub multipole connector  
25pole.

Valve positions:  
– Combination mono-/  
bistabil  
Outputs  
max. 22  
max. 18 (monostable)

On request:  
Expandable with external  
field bus components  
(Profi Bus DP, Inter Bus S,  
CAN Device net, AS-Interface)

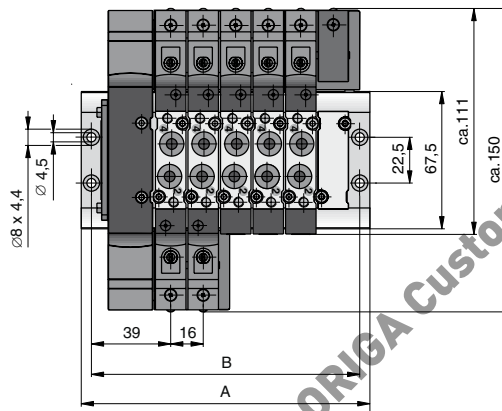
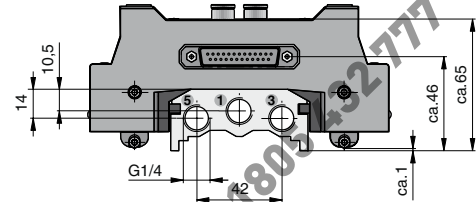
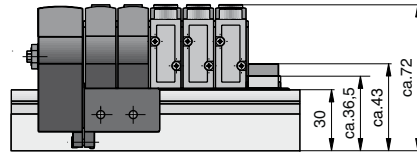

Drawing shows:  
6fold Valve Islands IM10-Q6-06, 24VDC  
Order No. PA10491-06-22  
Valve positions: JJMMMC

Dimension Table (mm)

Dimen- sion	Number of valves																	
	2	3	4	5	6	7	8	9	10	11	12	13	14	15	16	17	18	
A	78	94	110	126	142	158	174	190	206	222	238	254	270	286	302	318	334	
B	68	84	100	116	132	148	164	180	196	212	228	244	260	276	292	308	324	

For single valves see page 18-28, for order instructions see page 36

Dimensions in mm

**Order Instructions – Valve Islands**

Order No.										
P	A									
									Number of valves	Solenoid version voltage

Valve positions																		
Valve positions 1-16																		Flow divider to valve
1	2	3	4	5	6	7	8	9	10	11	12	13	14	15	16	17	18	



Version	
PA 10490	Valve Islands with threaded ports G1/8 Series: IM10-1/8
PA 10491	Valve Islands with push-in connections OD 6, Series: IM10-Q6

Valves	
02	2 valves
03	3 valves *
04	4 valves
05	5 valves
▼	
18	18 Valves
* uneven number of valve positions on request	

Solenoid version/voltage	
21	12 V DC
22	24 V DC

**Even and uneven numbers of valves are possible!**  
Please enter the codes for the valve types required.

Flow divider (for dual pressure operating) without (standard) .. at valve position

Order Codes for Valves and Cover Plates		
Code	Description	Page
A	Cover plate for unused valve position	41
C	Cover plate (monostable)*	41
O	Cover plate (bistabil)*	41
P	Intermediate air supply adapter G1/8	41
* including electrical socket		

Order Codes for Valves and Cover Plates		
Code	Description	Page
Electrically actuated		
K	2x 3/2 Way Valve NC, air spring return	19
N	2x 3/2 Way Valve NO, air spring return	19
H	2x 3/2 Way Valve NC, NO, air spring return	19
M	5/2 Way Valve, spring return	24
L	5/2 Way Valve, air spring return	24
J	5/2 Way Valve, impulse	24
D	5/2 Way Valve, impulse, with biased position	25
G	5/3 Way Valve, middle position closed, spring return to middle position	25
E	5/3 Way Valve, middle position exhausted, spring return to middle position	25
B	5/3 Way Valve, middle position pressurized, spring return to middle position	25

Order Codes for Valves and Cover Plates		
Code	Description	Page
Electrically actuated, with external pilot air		
X	2x 3/2 Way Valve NC, air spring return	19
Y	2x 3/2 Way Valve NO, air spring return	19
Z	2x 3/2 Way Valve NC, NO, air spring return	19
F	5/2 Way Valve, spring return	24
R	5/2 Way Valve, air spring return	24
S	5/2 Way Valve, impulse	24
T	5/2 Way Valve, impulse, with biased position	25
U	5/3 Way Valve, middle position closed, spring return to middle position	25
W	5/3 Way Valve, middle position exhausted, spring return to middle position	25
V	5/3 Way Valve, middle position pressurized, spring return to middle position	25

Not for new design - Please contact IGFA Customer Service: +49 2005 432 7777

# RPS-Manifolds

for Directional Valves  
 – Series S10-1/8  
 – Series S10-Q6

RPS manifolds reduce and simplify the tubing layout. They provide a space-saving, clear and simple, compact solution. RPS manifolds have a common compressed air supply port (P) and common exhaust ports (R, S). From 2 to 16 valves can be mounted on them. (Other sizes available on request)

- Materials:**  
 RPS manifold  
 – aluminium  
 Screws  
 – galvanized steel  
 Gasket  
 – oil-resistant rubber

Dimension Table (mm) – Type: RPSL-S10-1/8-..

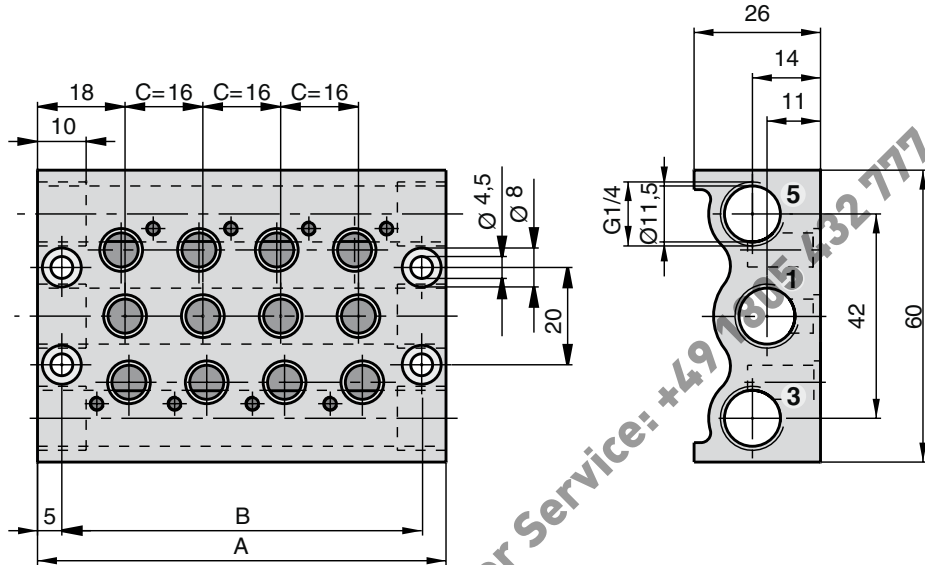

Drawing shows: 4fold valve manifold

Dimension Table (mm)

Type	Number of valves	Dimension	
		A	B
RPSL-S10-1/8-02	02	52	42
RPSL-S10-1/8-04	04	84	74
RPSL-S10-1/8-06	06	116	106
RPSL-S10-1/8-08	08	148	138
RPSL-S10-1/8-10	10	180	170
RPSL-S10-1/8-12	12	212	202
RPSL-S10-1/8-14	14	244	234
RPSL-S10-1/8-16	16	276	266

Order Instructions and Weight

Order Instructions *		consisting of			Weight (mass) [kg]
Type	Order No.	Manifold	Screws	Seals	
RPSL-S10-1/8-02	PD47254-0002	1	4	2	0.116
RPSL-S10-1/8-04	PD47254-0004	1	8	4	0.190
RPSL-S10-1/8-06	PD47254-0006	1	12	6	0.264
RPSL-S10-1/8-08	PD47254-0008	1	16	8	0.337
RPSL-S10-1/8-10	PD47254-0010	1	20	10	0.410
RPSL-S10-1/8-12	PD47254-0012	1	24	12	0.484
RPSL-S10-1/8-14	PD47254-0014	1	28	14	0.557
RPSL-S10-1/8-16	PD47254-0016	1	32	16	0.630

\*other versions on request



For single valves see page 18-28, for order instructions see page 36

Dimensions in mm



**Dimension Table (mm) – Type: RPSL-S10-1/4-..**

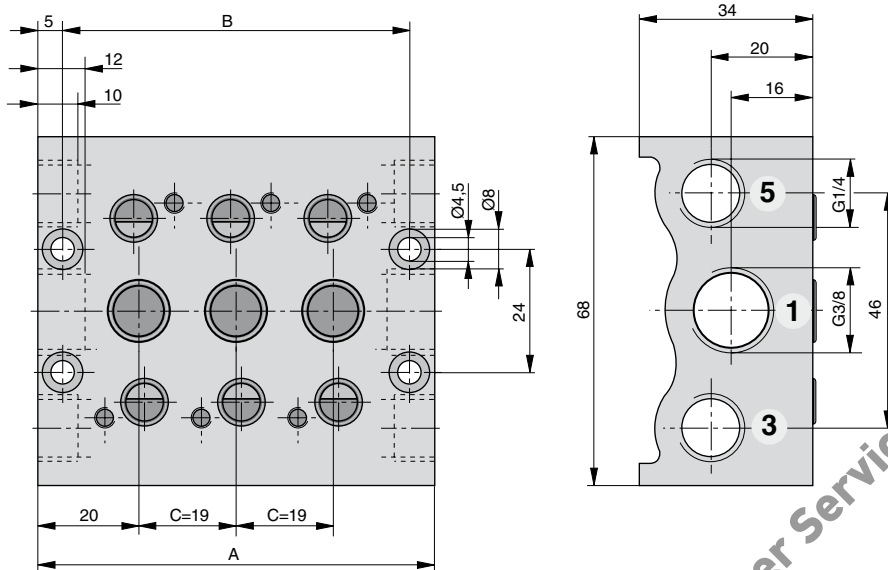

Drawing shows: 3fold manifold

**Maßtabelle (mm)**

Type	Number of valves	Dimension	
		A	B
RPSL-S10-1/4-02	02	59	49
RPSL-S10-1/4-04	04	97	87
RPSL-S10-1/4-06	06	135	125
RPSL-S10-1/4-08	08	173	163
RPSL-S10-1/4-10	10	211	201
RPSL-S10-1/4-12	12	249	239
RPSL-S10-1/4-14	14	287	277
RPSL-S10-1/4-16	16	325	315

**Order Instructions and Weight**

Order Instructions *	Order No.	consisting of			Weight (mass) [kg]
		Manifold	Screws	Seals	
RPSL-S10-1/4-02	PD49210-0002	1	4	2	0.255
RPSL-S10-1/4-04	PD49210-0004	1	8	4	0.424
RPSL-S10-1/4-06	PD49210-0006	1	12	6	0.594
RPSL-S10-1/4-08	PD49210-0008	1	16	8	0.736
RPSL-S10-1/4-10	PD49210-0010	1	20	10	0.932
RPSL-S10-1/4-12	PD49210-0012	1	24	12	1.101
RPSL-S10-1/4-14	PD49210-0014	1	28	14	1.270
RPSL-S10-1/4-16	PD49210-0016	1	32	16	1.439

\*other versions on request

For single valves see page 18-28

Dimensions in mm

# RPS Manifolds

for Directional Valves  
– Series S10-1/4  
– Series S10-Q8

RPS manifolds reduce and simplify the tubing layout. They provide a space-saving, clear and simple, compact solution.

RPS manifolds have a common compressed air supply port (P) and common exhaust ports (R, S).

From 2 to 16 valves can be mounted on them. (Other sizes available on request)

**Materials:**

- RPS manifold
- aluminium
- Screws
- galvanized steel
- Gasket
- oil-resistant rubber



## Accessories

for Valve Manifold Assemblies

### Flow Divider

**Material:** Aluminium

**Order No.**

- S10-1/8 (Q6): **PD47353**
- S10-1/4 (Q8): **PD49322**

### Cover Plate for unused Valve Positions

**Material:** Aluminium

**Order No.**

- S10-1/8 (Q6): **KL9114**
- S10-1/4 (Q8): **KL9186**

### Intermediate Air Supply Adapter

**Material:** Aluminium

**Order No.**

- S10-1/8 (Q6): **KL9115**
- S10-1/4 (Q8): **KL9187**

### Clamp Mounting for DIN Rail 35 mm



**Versions:**

- for Valve Manifolds S10
- for Valve Islands IM10

**Material:** Aluminium

**The delivery includes:**

- 1 clamp mounting
- 4 screws

#### Order Instructions – Clamp Mounting for S10-1/8 (Q6)

Clamp Mounting Number of valves	Order No.	
	for valve manifolds Type: S10-1/8	for valve islands Type: IM10-1/8
2	PD47393-0002	PD47949-0002
4	PD47393-0004	PD47949-0004
6	PD47393-0006	PD47949-0006
8	PD47393-0008	PD47949-0008
10	PD47393-0010	PD47949-0010
11 – 18	on request	PD48270

#### Order Instructions – Clamp Mounting for S10-1/4 (Q8)

Clamp Mounting valves	Order No.
	for RPS-manifold Type: RPSL-S10-1/4-..
2	PD49423-0002
4	PD49423-0004
6	PD49423-0006
8	PD49423-0008
10	PD49423-0010
12-16	on request

### Cable with D-Sub multipole connector 25pole

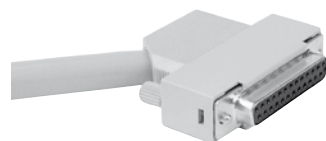

#### Order Instructions – Cable

Cable length	Electrical protection	Order No.
2 m	IP40	KL3355
5 m	IP40	KL3356
5 m	IP65	KL3357

Dimensions in mm

**Dimension Table – Mounting Bracket for Single Valves**

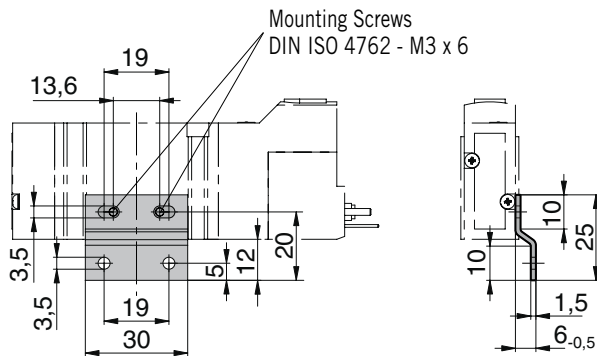

*Mounting Bracket for Single Valves Series S10*

**Accessories**  
*for Single Valves*

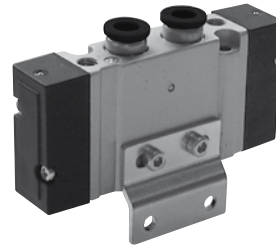

**Material:** Steel, passivated

**Order No.:** KL9112

**Dimension Table – Adapter Plate for Single Valves S10-1/8 (Q6)**

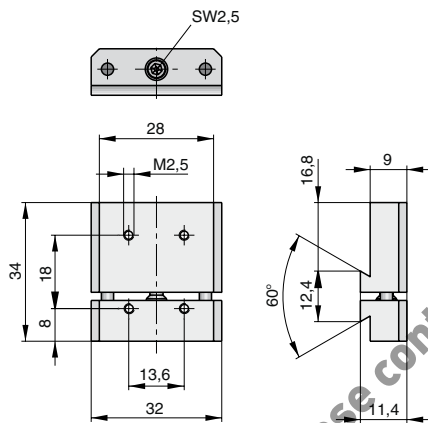

*Adapter Plate for Single Valves Series S10-1/8 (Q6) Series S10-1/4 (Q8)*

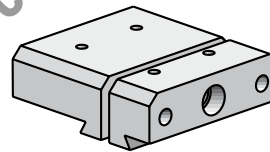

Adapter plate for direct mounting on Parker Origa profile cylinders

**Dimension Table – Adapter Plate for Single Valves S10-1/4 (Q8)**

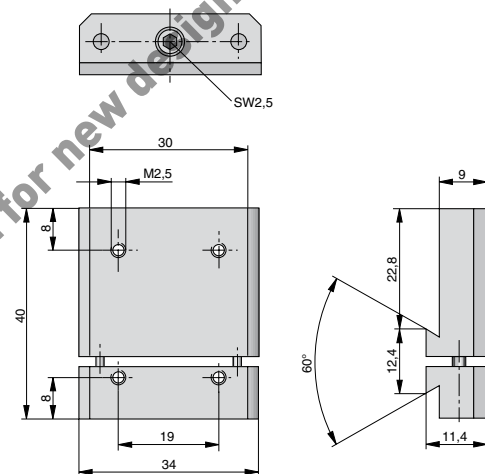

**Material:** Aluminium

**Order No.**

– S10-1/8 (Q6): **PD47420**

– S10-1/4 (Q8): **PD49325**

Dimensions in mm

# Accessories

for Single Valves

Connectors  
for Series S10



- Standard version
- version with LED

**Material:** Plastic

Dimension Table – Connector

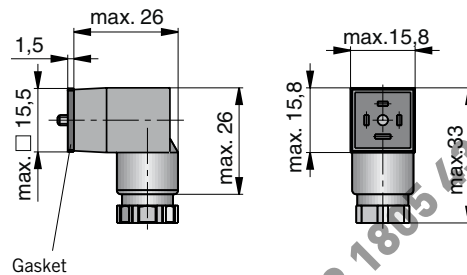

**Versions and Order Instructions**

Version	Voltage	Colour	Order No.
Standard version	230 V AC/DC	black	KL9052
Bipolar LED and VDR to protect supply and switch	230 V AC	transparent	KL9056
	24 V DC	transparent	KL9118

Not for new design - Please contact ORIGINAL Customer Service: +49 1805 132777

Dimensions in mm

## Contents

Version	Actuation System	Page		
		Characteristics	Dimension Table	Order Instructions Overview
3/2 Way Valves Series S9-G1/8, G1/4, G1/2	Manual Control pneumatic electric	44-47	48-55	70-72
for panel mounting to DIN 43696 (G1/8)	Manual Control			
5/2 Way Valves Series S9-G1/8, G1/4, G1/2	Manual Control pneumatic electric	44-47	56-63	73-74
for panel mounting to DIN 43696 (G1/8)	Manual Control			
5/3 Way Valves Series S9-G1/8, G1/4, G1/2	Manual Control pneumatic electric	44-47	64-69	75-77
3/2 , 5/2 and 5/3 Way Valve combinations with Logic Elements Series S9-G1/8, G1/4	Pneumatic AND OR TIMER	44-47	78-79	79

## Directional Control Valves

Series  
S9-G1/8 to G1/2

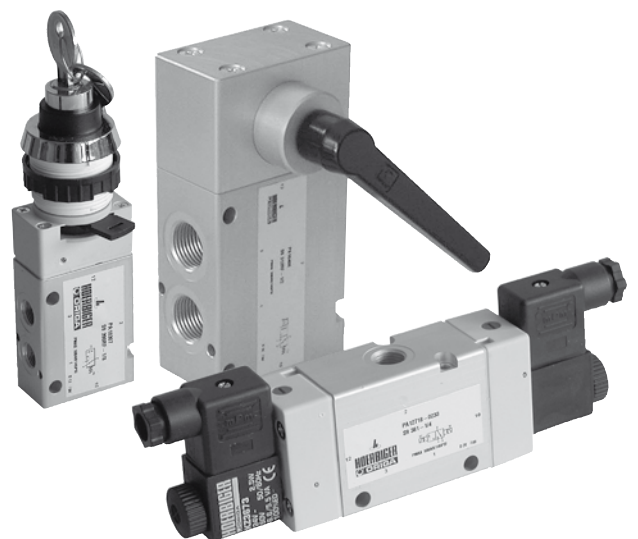

# 3/2, 5/2 and 5/3 Directional Control Valves

Series  
S9-G1/8 to G1/2

\* Valve Manifold Assemblies  
with electrically actuated  
valves -10 to +50°C

(<sup>1</sup> Note:  
For use below freezing point  
please contact us

(<sup>2</sup> Actuation force for valves  
without spring return,  
actuation with rotary lever:  
5N

(<sup>3</sup> Actuation force for valves  
with spring return,  
Actuation with rotary lever:  
15N

(<sup>4</sup> Only for version with biased  
position 2 – 10 bar,  
pneumatically actuated  
2 – 10 bar, electrically  
actuated 2.5 – 10 bar

(<sup>5</sup> Version with biased position  
2.5 – 10 bar

(<sup>6</sup> Low wattage version:  
Plug to  
DIN EN 175301-803  
form A

(<sup>7</sup> Version “middle position  
vented“ 1000 l/min

(<sup>8</sup> Version “middle position  
vented“ 3300 l/min

Version “middle position  
pressured“ 3600 l/min

(<sup>9</sup> 5/3 Way Valve 2.5 – 10 bar

(<sup>10</sup> Valves with panel mounting  
actuators 2 – 10 bar

## Series S9 – G1/8 to G1/2

Characteristics	Symbol	Unit	Series S9 G1/8		
Actuation			Manual control	pneumatic	electrical
General Features					
Type			Spool valve		
Mounting			2 Screws M5		
Tube connection			Thread		
Thread			G1/8 – 7.4 deep		
Weight		kg	See page 48, 56, 64		
Installation			In any position		
Ambient temperature range ( <sup>1</sup> T <sub>min. / max.</sub> )		°C	-10 to +60 *		
Medium temperature range ( <sup>1</sup> T <sub>min. / max.</sub> )		°C	-10 to +60 *		
Medium			Filtered compressed air		
Lubrication			With or without oil mist lubrication (We recommend the use of mineral oil type VG 32 to ISO 3448)		
Pneumatische Characteristics					
Nominal pressure	p <sub>min. / max.</sub>	bar	6		
Operating pressure range	p <sub>min. / max.</sub>	bar	0–10 ( <sup>10</sup> )	–	–
– permanent signal version	p <sub>min. / max.</sub>	bar	–	0–10	2–10
– impulse version	p <sub>min. / max.</sub>	bar	–	0–10	2–10
– with external pilot air	p <sub>min. / max.</sub>	bar	–	–	0–10
Nominal flow	QN	l/min	500 (450 bei 3/2 Way Valve)		
Actuation					
Manual control			Direct		
Stroke		mm	4.5		
Actuation force	F <sub>b</sub>	N	7 ( <sup>2</sup> ) 10 ( <sup>3</sup> )		
Actuation force for panel mounting actuators			See page 48		
Pneumatic			Direct		
Actuation pressure range					
– permanent signal version	p <sub>min. / max.</sub>	bar	–	2–10	2–10
– impulse version	p <sub>min. / max.</sub>	bar	–	1.5–10	1.5–10
Electrical					
Electrical			Electrical pilot operated		
Voltage type			Alternating current (50/60Hz)		
Nominal voltage					
– Standard version	U <sub>n</sub>	V	230 ±10%		
– Low wattage version	U <sub>n</sub>	V	230 ±10%		
Initial power consumption					
– Standard version		VA (W)	G1/8	G1/4	G1/2
– Low wattage version		VA (W)	8.5	8.5	11.0
– Standard version		VA (W)	6.6	6.6	7.8
– Low wattage version		VA (W)	6.0	6.0	8.5
Continuous consumption					
– Standard version		VA (W)	G1/8	G1/4	G1/2
– Low wattage version		VA (W)	6.0	6.0	8.5
– Standard version		VA (W)	3.9	4.9	4.9
– Low wattage version		VA (W)	3.9	4.9	4.9
Duty cycle	ED	%	100		
Electrical protection		IP	IP65 to DIN 40050 (applies only to solenoid with plug)		
Connection			Plug to DIN EN 175301-803 form B – industrial standard ( <sup>6</sup> )		

Series S9 G1/4			Series S9 G1/2		
Manual control	pneumatic	electrical	Manual control	pneumatic	electrical
Spool valve			Spool valve		
2 Screws M6			2 Screws M6		
Thread			Thread		
G1/4 – 11 deep			G1/2 – 16 deep		
See page 52, 60, 66			See page 54, 62, 68		
In any position			In any position		
-10 to +60 *			-10 to +60 *		
-10 to +60 *			-10 to +60 *		
6			6		
0-10			0-10		
-	0-10	2-10	-	0-10	2.2-10
-	0-10	2-10	-	0-10	2.2-10
-	-	0-10	-	-	0-10
1300 <sup>(7)</sup>			3500 <sup>(8)</sup>		
Direct			Direct		
6.5			9.4		
10 <sup>(2)</sup>			15 <sup>(2)</sup>		
15 <sup>(3)</sup>			40 <sup>(3)</sup>		
-			-		
Direct			Direct		
2-10	2-10	2-10	-	2.2-10 <sup>(9)</sup>	2.2-10
1.5-10	1.5-10 <sup>(4)</sup>	1.5-10 <sup>(4)</sup>	-	1.5-10 <sup>(5)</sup>	1.5-10 <sup>(4)</sup>
Direct current					
24 ±10%			Other voltages on request		
24 ±10%					
G1/8	G1/4	G1/2			
2.5	2.5	4.8			
2.1	2.1	2.7			
G1/8	G1/4	G1/2			
2.5	2.5	4.8			
2.1	2.1	2.7			

# 3/2, 5/2 and 5/3 Way Valves for use in EX areas

Series  
S9-G1/8 to G1/2

\* Valve Manifold Assemblies  
with electrically actuated  
valves -10 to +50°C

- (<sup>1</sup> Note:  
For use below freezing  
point please contact us  
(<sup>2</sup> Actuation force for valves  
without spring return,  
Actuation with rotary lever:  
5N  
(<sup>3</sup> Actuation force for valves  
with spring return,  
actuation with rotary lever:  
15N  
(<sup>4</sup> Only for version with biased  
position pneumatically  
actuated 2 – 8 bar,  
electrically actuated  
2.5 – 8 bar  
(<sup>5</sup> Version with biased position  
2.5 – 8 bar  
(<sup>6</sup> Maximum power if warmed  
up to termal load limit  
(<sup>7</sup> Version “middle position  
vented“ 1000 l/min  
(<sup>8</sup> Version “middle position  
vented“ 3300 l/min  
Version “middle position  
pressured“ 3600 l/min  
(<sup>9</sup> 5/3 Way Valve 2.5 – 8 bar  
(<sup>10</sup> Valves with panel mounting  
actuators 2 – 8 bar

## Series S9 – G1/8 to G1/2

Characteristics	Symbol	Unit	Series S9 G1/8		
Actuation			Manual Control	pneumatic	electrical
General Features					
Type			Spool valve		
Mounting			2 screws M5		
Tube connection			Thread		
Thread			G1/8 – 7.4 deep		
Weight		kg	See page 48, 56, 64		
Installation			In any position		
Ambient temperature range ( <sup>1</sup> T <sub>min. / max.</sub> )		°C	-10 to +60 *		
Medium temperature range ( <sup>1</sup> T <sub>min. / max.</sub> )		°C	-10 to +60 *		
Medium			Filtered, unlubricated compressed air – free from water and dirt to ISO8573-1		
Pneumatic Characteristics					
Nominal pressure	p <sub>min. / max.</sub>	bar	6		
Operating pressure range	p <sub>min. / max.</sub>	bar	0–8 ( <sup>10</sup> )	–	–
– permanent signal version	p <sub>min. / max.</sub>	bar	–	0–8	2–8
– impulse version	p <sub>min. / max.</sub>	bar	–	0–8	1.5–8( <sup>4</sup> )
– with external pilot air	p <sub>min. / max.</sub>	bar	–	–	0–8
Nominal flow	QN	l/min	500 (450 bei 3/2 Way Valve)		
Actuation					
Manual control			Direct		
Stroke		mm	4.5		
Actuation force	Fb	N	7 ( <sup>2</sup> ) 10 ( <sup>3</sup> )		
Actuation force for panel mounting actuators			See page 48		
Pneumatic					
Actuation pressure range					
– permanent signal version	p <sub>min. / max.</sub>	bar	–	2–8	2–8
– impulse version	p <sub>min. / max.</sub>	bar	–	1.5–8	1.5–8( <sup>4</sup> )
Electrical					
Certification					
Category, type of ignition protection			Single valve II 2G c T4T135°C-10°C≤Ta≤+60°C		
Voltage type					
Nominal voltage	UN	V	230 ±10%		
	UN	V	110 ±10%		
	UN	V	24 ±10%		
Power rating at UN					
		VA (W)	G1/8, G1/4, G1/2 3.1 (230V)		
		VA (W)	3.0 (110V)		
		VA (W)	2.5 (24V)		
Max. power at Un ( <sup>6</sup> )					
		VA (W)	G1/8, G1/4, G1/2 2.9 (230V)		
		VA (W)	2.8 (110V)		
		VA (W)	2.4 (24V)		
Electrical protection	IP		IP65 (applise only to solenoid with cable)		
Connection			Cable – cable lengths see Order Instructions		



Series S9 G1/4			Series S9 G1/2		
Manual Control	pneumatic	electrical	Manual Control	pneumatic	electrical
Spool valve			Spool valve		
2 Screws M6			2 Screws M6		
Thread			Thread		
G1/4 – 11 deep			G1/2 – 16 deep		
See page 52, 60, 66			See page 54, 62, 68		
In any position			In any position		
-10 to +60 *			-10 to +60 *		
-10 to +60 *			-10 to +60 *		
Solids: Class 7 particle size <40 µm for gas			Water content: pressure dew point + 3°C, Class 4, but at least 5°C below minimum operating temperature		
6			6		
0–8	–	–	0–8	–	–
–	0–8	2–8	–	0–8	2.2–8
–	0–8	1.5–8 <sup>(4)</sup>	–	0–8	1.5–8 <sup>(4)</sup>
–	–	0–8	–	–	0–8
1300 <sup>(7)</sup>			3500 <sup>(8)</sup>		
Direct			Direct		
6.5			9.4		
10 <sup>(2)</sup>			15 <sup>(2)</sup>		
15 <sup>(3)</sup>			40 <sup>(3)</sup>		
–			–		
Direct			Direct		
2–8	2–8	2–8	–	2.2–8 <sup>(9)</sup>	2.2–8
1.5–8	1.5–8 <sup>(4)</sup>	1.5–8 <sup>(4)</sup>	–	1.5–8 <sup>(5)</sup>	1.5–8 <sup>(4)</sup>
EC Type Test Certificate for solenoid: PTB-No. 03 Ex IEC 2019X and PTB 03 ATEX 2018X toT5					
Solenoid/individual use: II 2G EEx m II T5 -20°C≤Ta≤+50°C Solenoid/manifold mounting: II 2G EEx m II T5 -20°C≤Ta≤+40°C					
Direct current					
24 ±10%			Other voltages on request		
G1/8, G1/4, G1/2					
3.3 (24V)					
G1/8, G1/4, G1/2					
3.0 (24V)					

# 3/2 Way Valves Series S9

G1/8

**Actuation:**

- Hand lever
- Pneumatic
- Electrical pilot operated
- Electrical pilot operated with external pilot air
- Panel mounting actuators for mounting diameter to DIN 43696

**Versions:**

- Normally closed
- Normally open
- With external pilot air
- Version to ATEX Standard

**Note:**

The "normally open" valve S9 381S-RF-1/8 cannot be used on a P-supply manifold.

**Weight (mass) kg**

Description	Type	Weight (mass) kg
Hand lever indexed	S9 311-1/8	0.162
- with spring return	S9 311RF-1/8	0.162
Pneumatic, by permanent signal	S9 361RF-1/8	0.137
Pneumatic, by impulse	S9 361-1/8	0.147
Electrical, by permanent signal	S9 381(S)RF-1/8	0.247
Electrical, by impulse	S9 381(S)-1/8	0.382

**Weight (mass) kg and action forces for valves with panel mounting actuators**

Description	Type	Actuation force (N, Nm)	Weight (mass) kg
Rotary lever	S9 312T-1/8	0.3	0.137
	S9 312T-RF-1/8	0.3	0.137
Pushbutton	S9 313T-RF-1/8	8.0	0.137
Mushroom pushbutton	S9 315T-RF-1/8	8.0	0.137
Locking switch	S9 316T-1/8	9.0	0.202
Rotary switch	S9 317T-1/8	0.3	0.127
Mushroom pushbutton emergency-Off	S9 318T-1/8	10.0	0.137

**Hand lever actuated**

Type: S9 311-1/8, S9 311RF-1/8

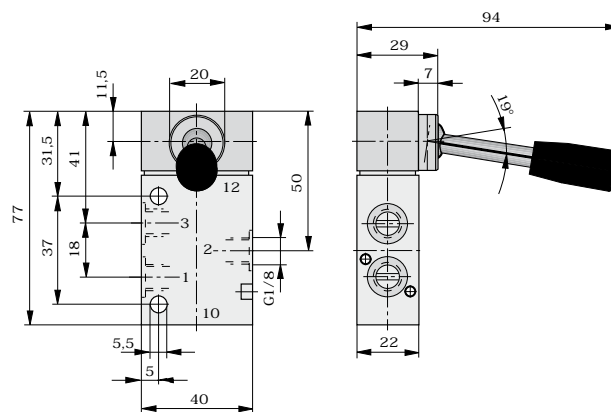

For order instructions see page 70-72, characteristics see page 44-47 and for RPS manifolds see page 93-100, Valve Islands see page 87-92

Dimensions in mm

**Pneumatically actuated – Type: S9 361-1/8, S9 361RF-1/8**

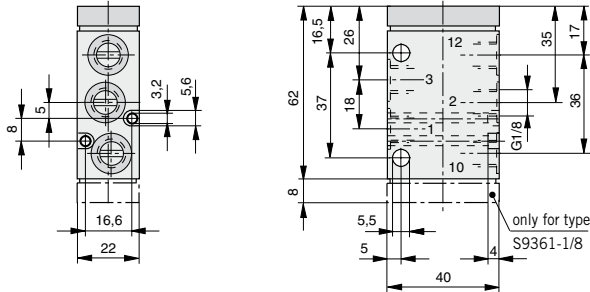

**Electrically actuated – Type: S9 381(S)-1/8, S9 381(S)RF-1/8**

**Solenoid for use in EX areas – Dimensions**

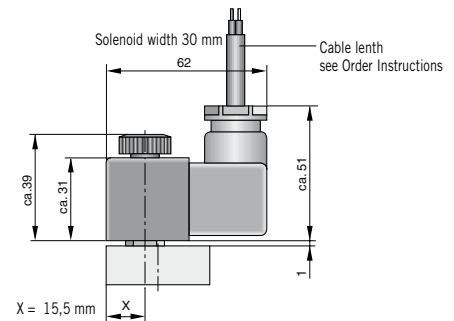
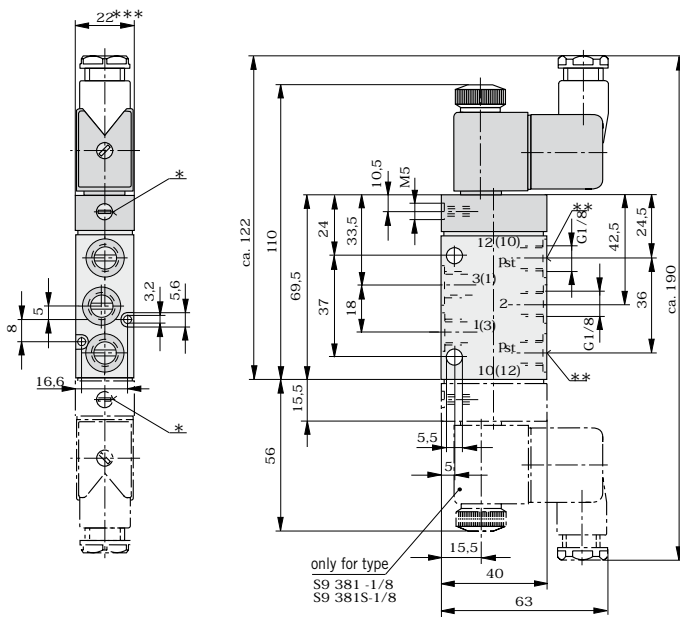

For more information on valves to ATEX standards see page 46, 47, 72

- \* Manual override
- \*\* Operating pressure supply  $p_{st}$  only for type S9 381S
- \*\*\* Solenoid width = 30 mm on low wattage coil version

For order instructions see page 70-72, characteristics see page 44-47 P-Manifolds and for RPS manifolds see page 93-100, Valve Islands see page 87-92

Dimensions in mm

**Basic valve for panel mounting actuators – Type: S9 390RF-1/8**

**Mounting diameter**

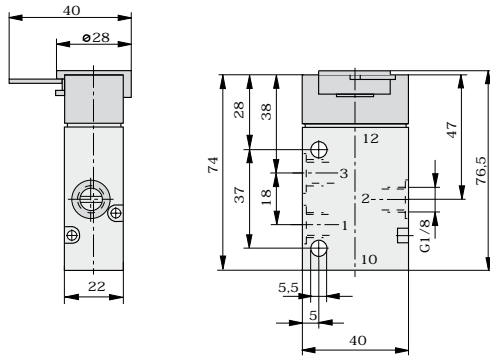

**Mounting diameter  $\varnothing 22$  mm**

**Mounting diameter  $\varnothing 30$  mm**

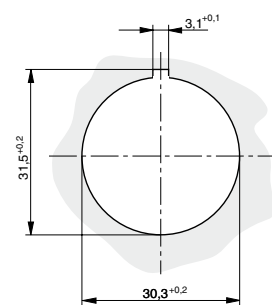
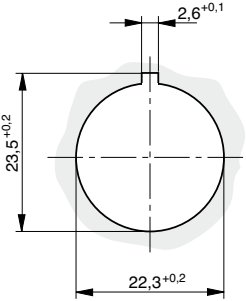

The actuators for these valves are interchangeable and can be mounted with 180° displacement on the basic valve. The actuators are not mounted upon delivery.

**Rotary lever, indexed – Type: 12T-22, 12T-30,**

**Pushbutton – Type: 13T-RF-22, 13T-RF-30**

**Mounting diameter  $\varnothing 22$  mm**

**Mounting diameter  $\varnothing 30$  mm**

**Mounting diameter  $\varnothing 22$  mm**

**Mounting diameter  $\varnothing 30$  mm**

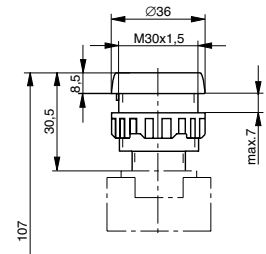
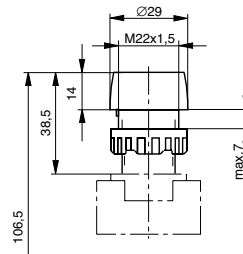
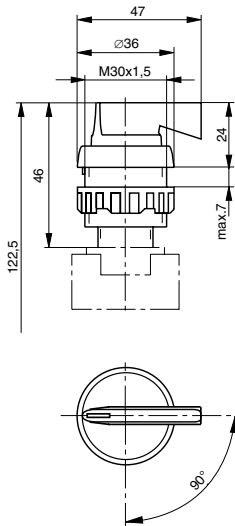
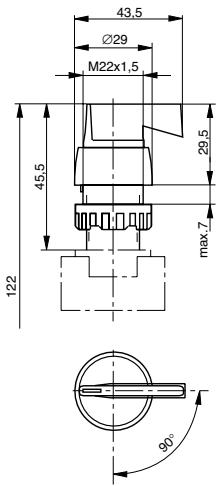

For order instructions see page 70-72, characteristics see page 44-47

Dimensions in mm

**Mushroom pushbutton – Type: 15T-RF-22, 15T-RF-30**

Mounting diameter  $\varnothing 22$  mm      Mounting diameter  $\varnothing 30$  mm

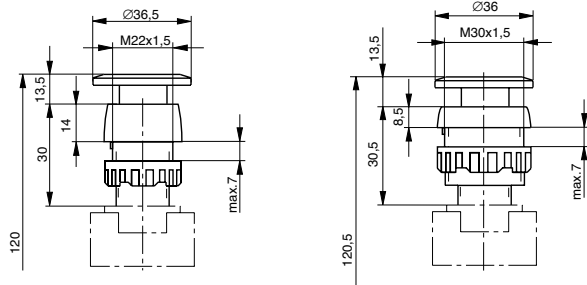

**Locking switch – Type: 16T-22, 16T-30**

Mounting diameter  $\varnothing 22$  mm      Mounting diameter  $\varnothing 30$  mm

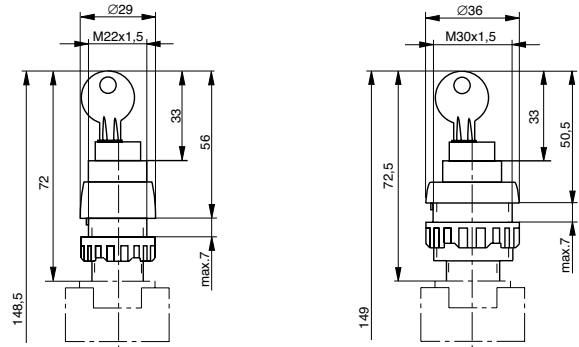

**Rotary lever with spring return – Type: 12T-RF-22, 12T-RF-30**

Mounting diameter  $\varnothing 22$  mm      Mounting diameter  $\varnothing 30$  mm

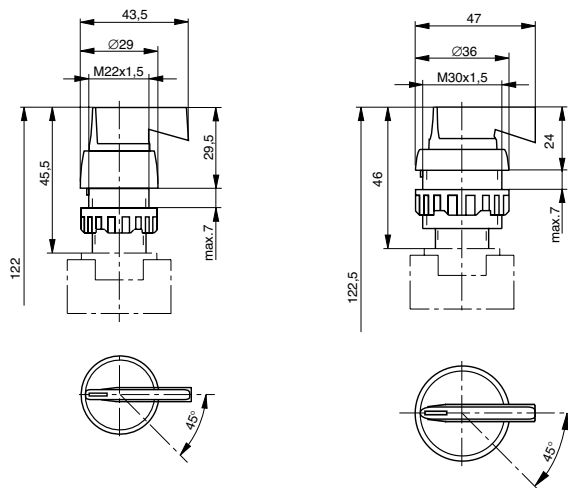

**Mushroom pushbutton emergency-Off – Type: 18T-22, 18T-30**

Mounting diameter  $\varnothing 22$  mm      Mounting diameter  $\varnothing 30$  mm

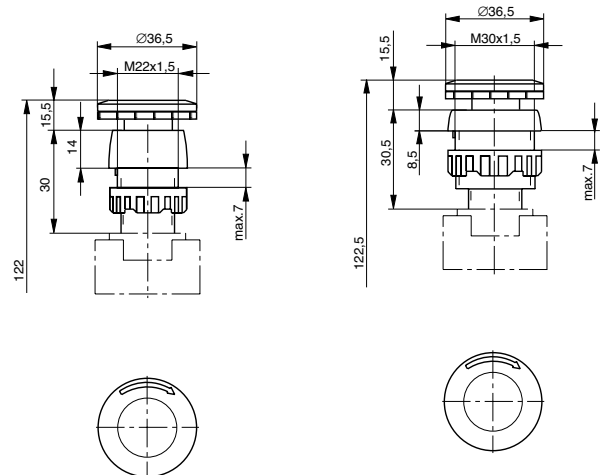

**Rotary switch – Type: 17T-22, 17T-30**

Mounting diameter  $\varnothing 22$  mm      Mounting diameter  $\varnothing 30$  mm

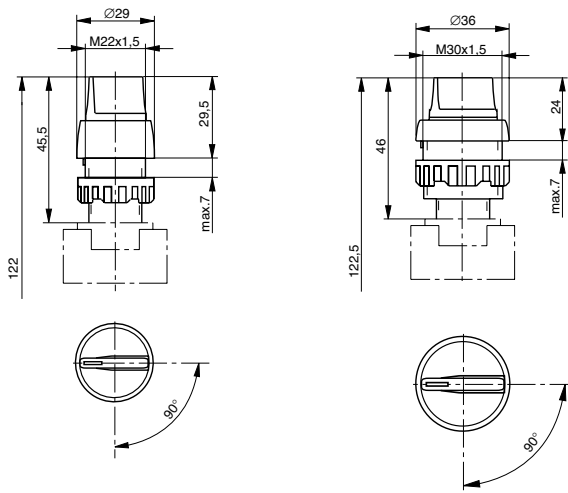

# 3/2 Way Valves Series S9

G1/4

### Actuation systems:

- Hand lever
- Pneumatic
- Electrical pilot operated
- Electrical pilot operated with external pilot air

### Versions:

- Normally closed
- Normally open
- With external pilot air
- With biased position
- Version to ATEX Standard

### Weight (mass) kg

Description	Type	Weight (mass)
Hand lever, indexed	S9 311-1/4	0.370
- with spring return	S9 311RF-1/4	0.370
Safety hand lever	S9 311S-1/4	0.370
Rotary lever, indexed	S9 312-1/4	0.370
- with spring return	S9 312RF-1/4	0.370
Pneumatic, by permanent signal	S9 361RF-1/4	0.370
Pneumatic, by impulse	S9 361-1/4	0.430
- with biased position	S9 362-1/4	0.430
Electrical, by permanent signal	S9 381(S) RF-1/4	0.500
Electrical, by impulse	S9 381(S)-1/4	0.600
- with biased position	S9 382(S)-1/4	0.600

### Hand lever actuated – Type: S9 311-1/4, S9 311RF-1/4

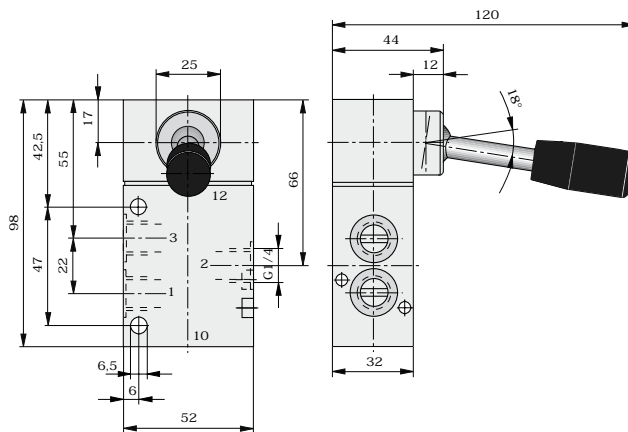

### Safety hand lever actuated – Type: S9 311S-1/4

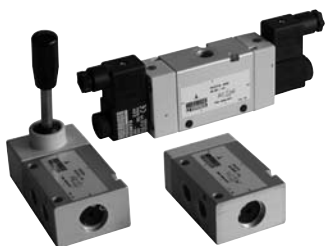
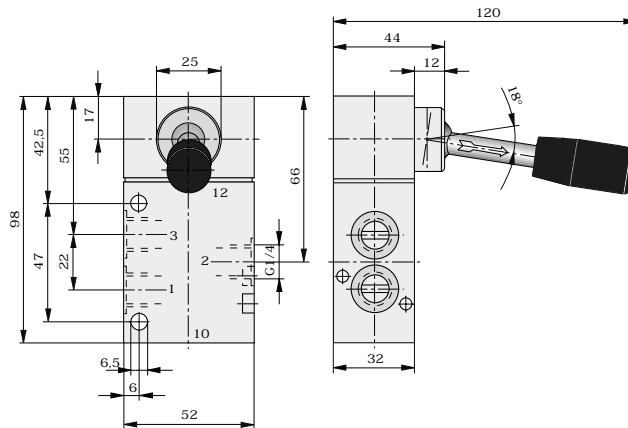

**Rotary lever actuated – Type: S9 312-1/4, S9 312RF-1/4**

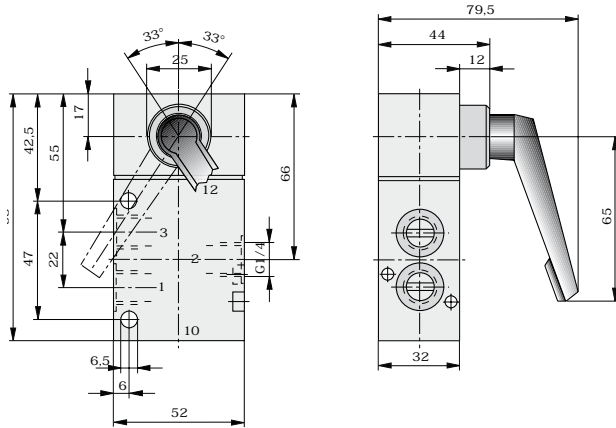

**Electrically actuated – Type: S9 381(S)-1/4, S9 382(S)-1/4, S9 381(S)RF-1/4**

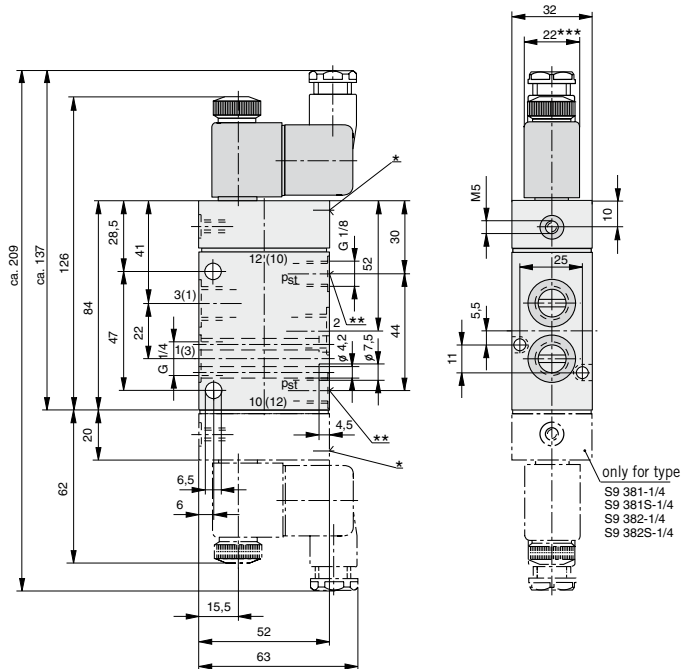

**Pneumatically actuated – Type: S9 361-1/4, S9 362-1/4, S9 361RF-1/4**

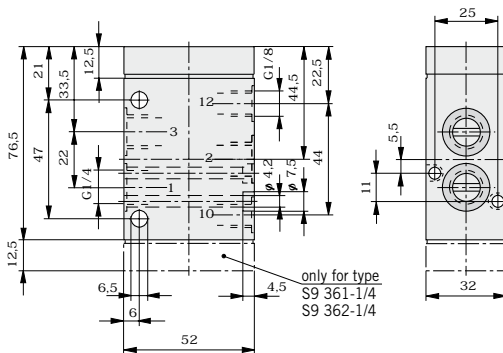

- \* Manual override
- \*\* Operating pressure supply  $p_{st}$  only for type S9 381S
- \*\*\* Solenoid width = 30 mm on low wattage coil version

**Note:**  
The “normally open“ valve S9 381S-RF-1/4 cannot be used on a P-supply manifold.

**Solenoid for use in EX areas  
Dimensions**

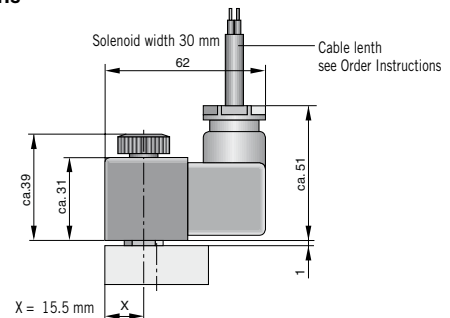

For more information on valves to ATEX standards see page 46, 47, 72

For order instructions see page 70-72, characteristics see page 44-47

Dimensions in mm

# 3/2 Way Valves Series S9

G1/2

### Actuation systems:

- Hand lever
- Pneumatic
- Electrical pilot operated
- Electrical pilot operated with external pilot air

### Versions:

- Normally closed
- Normally open
- With external pilot air
- With biased position
- Version to ATEX Standard

### Weight (mass) kg

Description	Type	Weight (mass)
Hand lever, indexed	S9 311-1/2	0.900
- with spring return	S9 311RF-1/2	0.900
Safety hand lever	S9 311S-1/2	0.900
Rotary lever, indexed	S9 312-1/2	0.950
-with spring return	S9 312RF-1/2	0.950
Pneumatic, by permanent signal	S9 361RF-1/2	0.700
Pneumatic, by impulse	S9 361-1/2	0.650
- with biased position	S9 362-1/2	0.650
Electrical, by permanent signal	S9 381(S) RF-1/2	0.770
Electrical, by impulse	S9 381(S)-1/2	1.008
- with biased position	S9 382(S)-1/2	1.008

### Hand lever actuated – Type: S9 311-1/2, S9 311RF-1/2

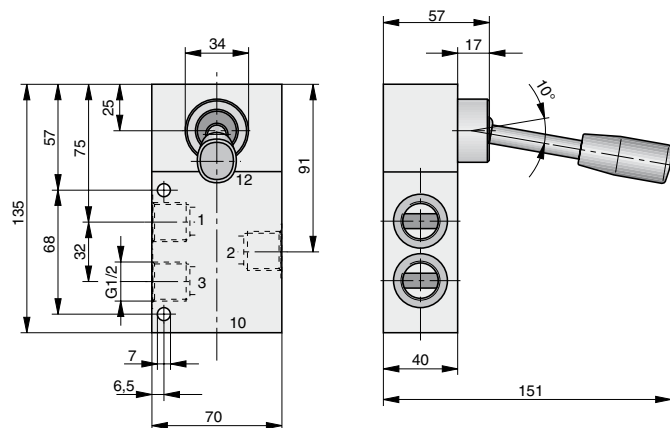

### Safety hand lever actuated – Type: S9 311S-1/2

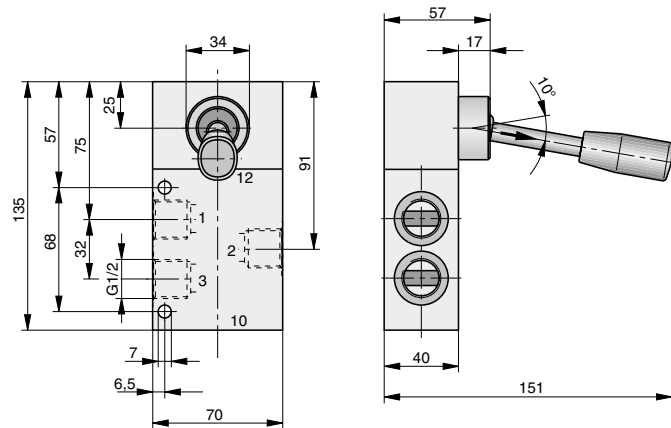



**Rotary lever actuated – Type: S9 312-1/2, S9 312RF-1/2**

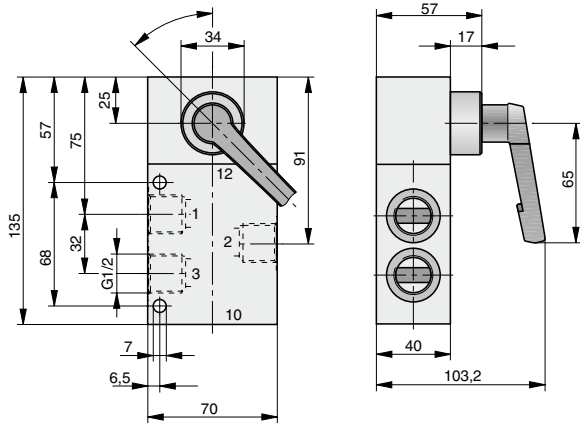

**Electrically actuated**

Type: S9 381(S)-1/2, S9 382(S)-1/2, S9 381(S)RF-1/2

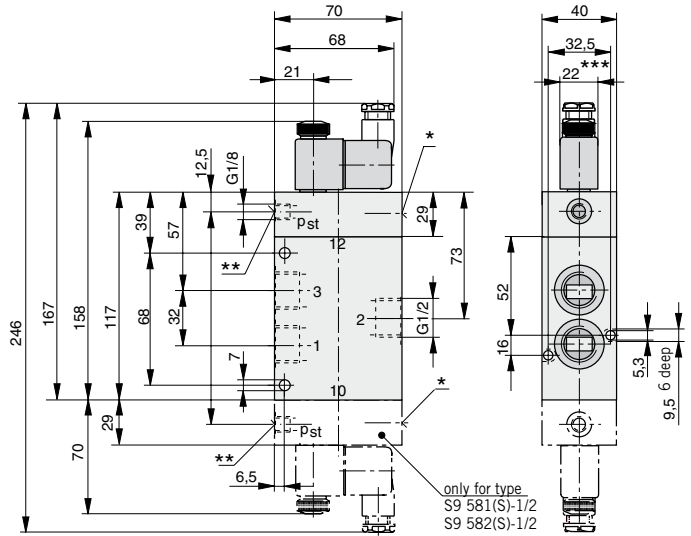

**Pneumatically actuated – Type: S9 361-1/2, S9 361RF-1/2**

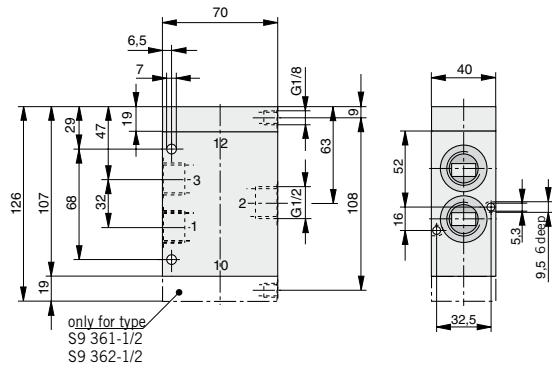

- \* Manual override
- \*\* Operating pressure supply  $p_{st}$  only for type S9 381S
- \*\*\* Solenoid width = 30 mm on low wattage coil version

**Note:**

The “normally open” valve S9 381S-RF-1/2 cannot be used on a P-supply manifold.

**Solenoid for use in EX areas  
Dimensions**

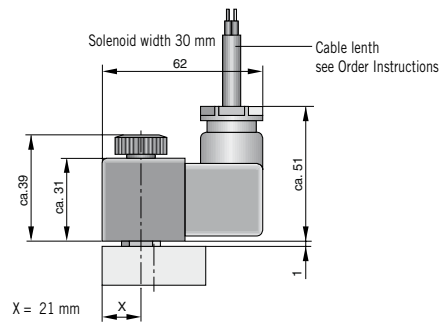

For more information on valves to ATEX standards see page 46, 47, 72

For order instructions see page 70-72, characteristics see page 44-47

Dimensions in mm

# 5/2 Way Valves Series S9

G1/8

### Actuation systems:

- Hand lever
- Safety hand lever
- Pneumatic
- Electrical pilot operated
- Electrical pilot operated with external pilot air
- Panel mounting actuators to DIN 43696

### Versions:

- With external pilot air
- With biased position
- Version to ATEX Standard

### Weight (mass) kg

Description	Type	Weight (mass)
Hand lever, indexed	S9 511-1/8	0.195
- with spring return	S9 511RF-1/8	0.195
Safety hand lever	S9 511S-1/8	0.195
Pneumatic, by permanent signal	S9 561RF-1/8	0.160
Pneumatic, by impulse	S9 561-1/8	0.170
Electrical, by permanent signal	S9 581(S)RF-1/8	0.280
Electrical, by impulse	S9 581(S)-1/8	0.415
- with biased position	S9 582-1/8	0.415

### Weight (mass) and actuating forces for valves with panel mounting

Description	Type	Actuating force (N, Nm)	Weight (mass) (kg)
Rotary lever	S9 512T-1/8	0.3	0.160
	S9 512T-RF-1/8	0.3	0.160
Pushbutton	S9 513T-RF-1/8	8.0	0.150
Mushroom pushbutton	S9 515T-RF-1/8	8.0	0.160
Locking switch	S9 516T-1/8	9.0	0.225
Rotary switch	S9 517T-1/8	0.3	0.150
Mushroom pushbutton emergency-Off	S9 518T-1/8	10.0	0.160

### Hand lever actuated – Type: S9 511-1/8, S9 511RF-1/8

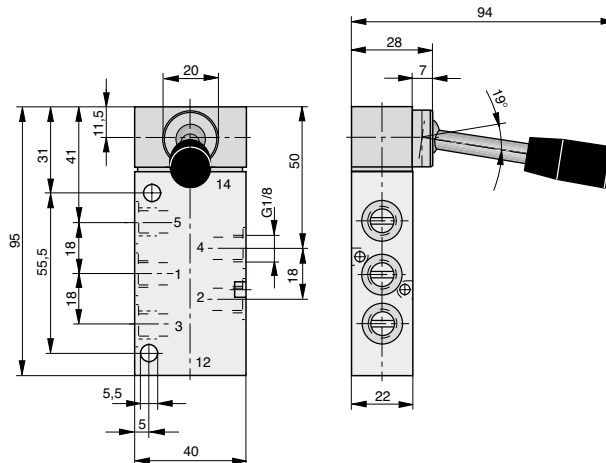

**Safety hand lever actuated – Type: S9 511S-1/8**

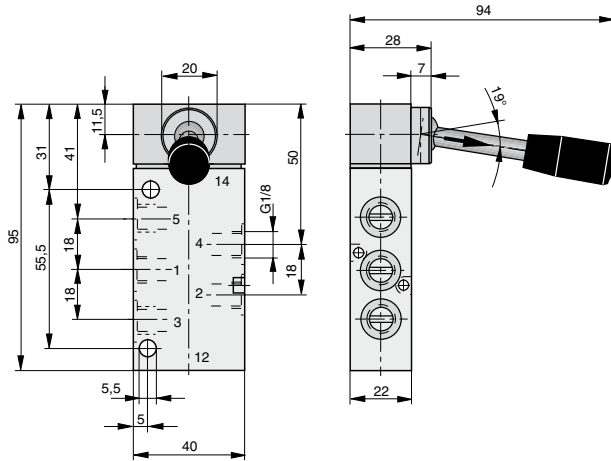

**Electrically actuated  
Type: S9 581(S)-1/8, S9 581(S)RF-1/8, S9 582-1/8**

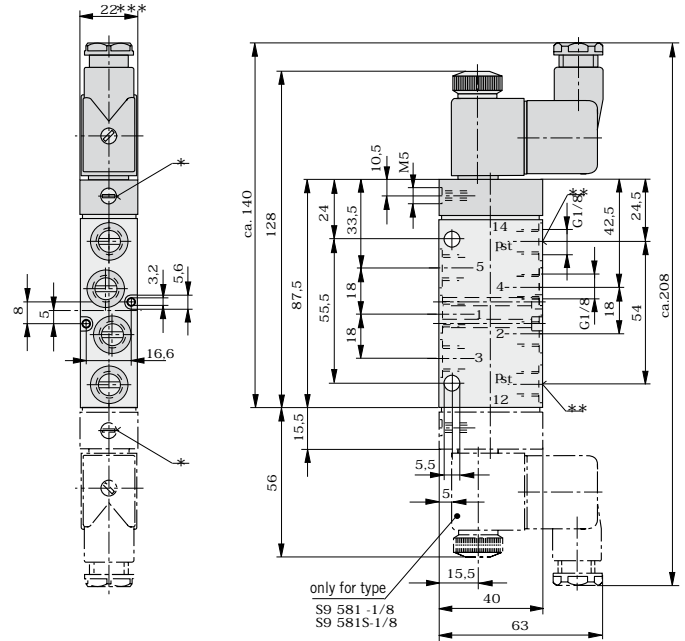

**Pneumatically actuated – Type: S9 561-1/8, S9 561RF-1/8**

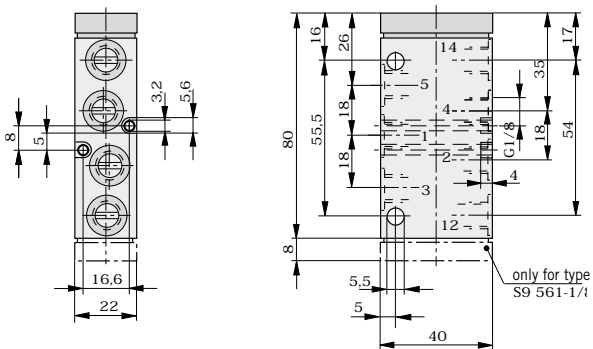

- \* Manual override
- \*\* Operating pressure supply  $p_{st}$  only for type S9 581S
- \*\*\* Solenoid width = 30 mm on low wattage coil version

**Solenoid for use in EX areas  
Dimensions**

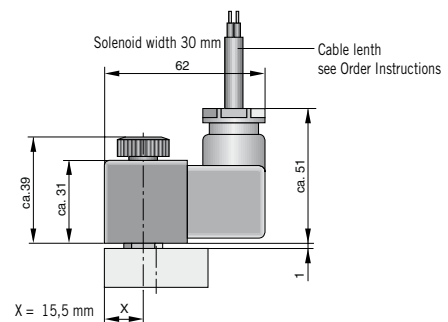

For more information on valves to ATEX standards see page 46, 47, 74

For order instructions see page 73, 74, characteristics see page 44-47

Dimensions in mm

**Basic valve for panel mounting actuators – Type: S9 590RF-1/8**

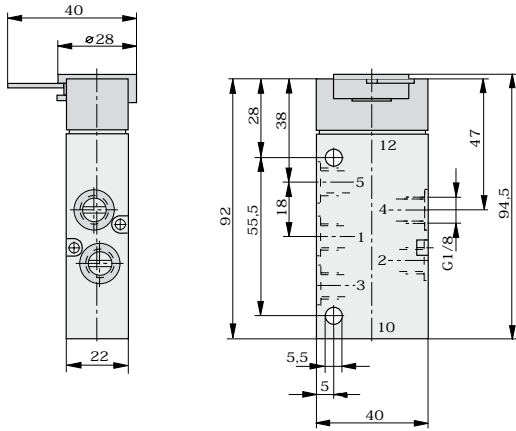

**Mounting diameter**

**Mounting diameter Ø22 mm**

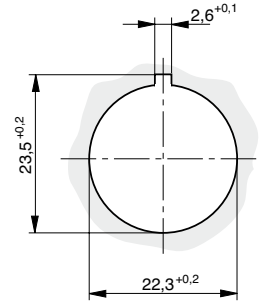

**Mounting diameter Ø30 mm**

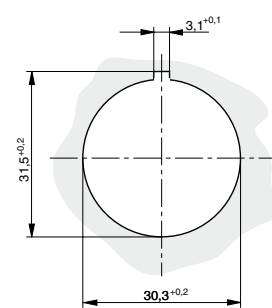

The actuators for these valves are interchangeable and can be mounted with 180° displacement on the basic valve. The actuators are not mounted upon delivery.

**Rotary lever, indexed – Type: 12T-22, 12T-30**

**Mounting diameter Ø22 mm**

**Mounting diameter Ø30 mm**

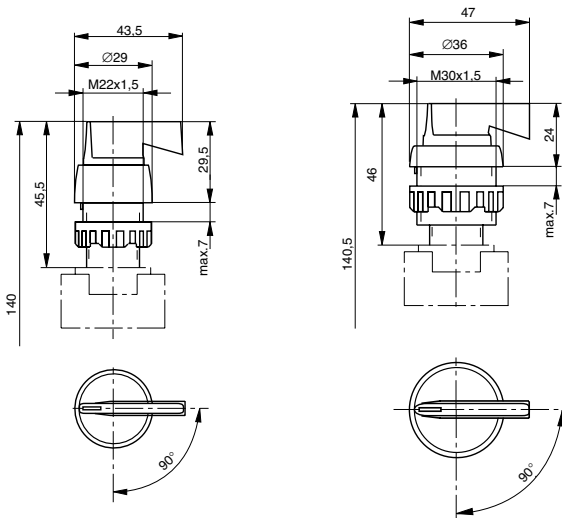

**Mushroom pushbutton – Type: 15T-RF-22, 15T-RF-30**

**Mounting diameter Ø22 mm**

**Mounting diameter Ø30 mm**

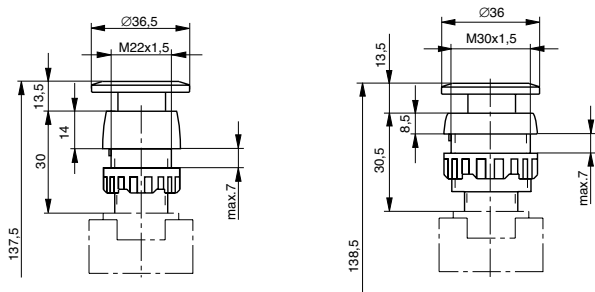

**Pushbutton – Type: 13T-RF-22, 13T-RF-30**

**Mounting diameter Ø22 mm**

**Mounting diameter Ø30 mm**

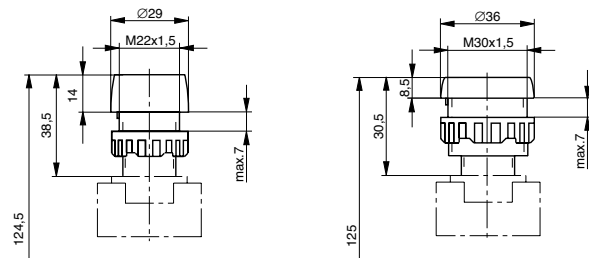

**Rotary switch – Type: 17T-22, 17T-30**

**Mounting diameter Ø22 mm      Mounting diameter Ø30 mm**

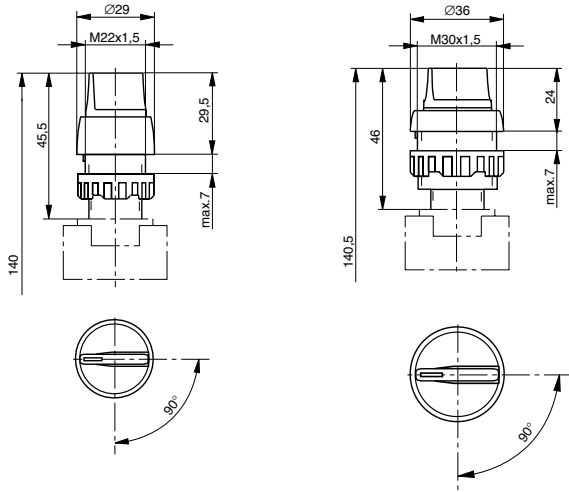

**Rotary lever with spring return – Type: 12T-RF-22, 12T-RF-30**

**Mounting diameter Ø22 mm      Mounting diameter Ø30 mm**

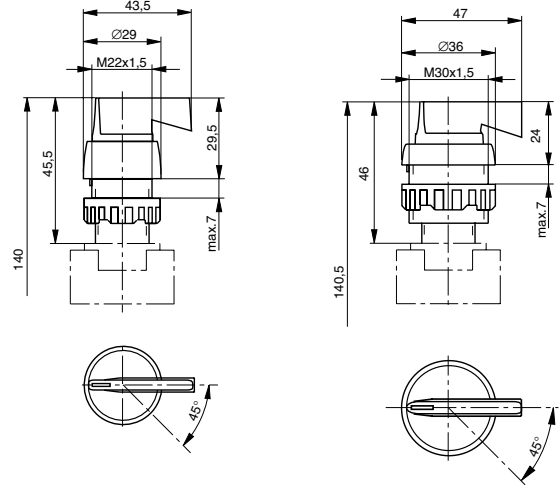

**Mushroom pushbutton emergency-Off – Type: 18T-22, 18T-30**

**Mounting diameter Ø22 mm      Mounting diameter Ø30 mm**

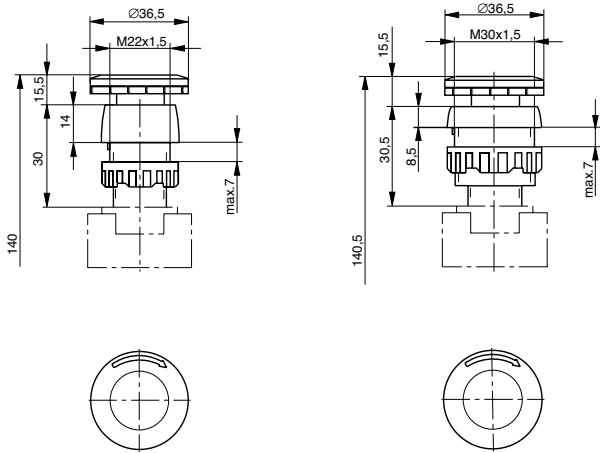

**Locking switch – Type: 16T-22, 16T-30**

**Mounting diameter Ø22 mm      Mounting diameter Ø30 mm**

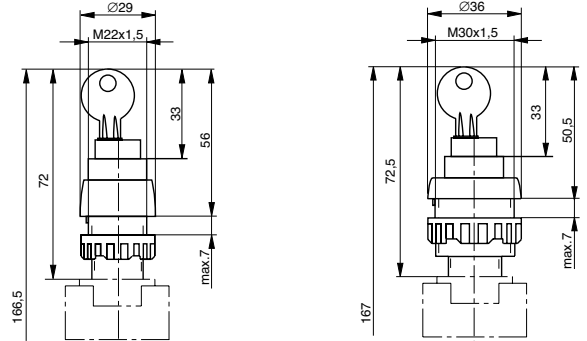

For order instructions see page 73, 74, characteristics see page 44-47

Dimensions in mm

# 5/2 Way Valves Series S9

G1/4

### Actuation systems:

- Hand lever
- Safety hand lever
- Pneumatic
- Electrical pilot operated
- Electrical pilot operated with external pilot air

### Versions

- With external pilot air
- With biased position
- Version to ATEX Standard

### Weight (mass) kg

Description	Type	Weight (mass)
Hand lever, indexed	S9 511-1/4	0.520
- with spring return	S9 511RF-1/4	0.520
Safety hand lever	S9 511S-1/4	0.520
Rotary lever, indexed	S9 512-1/4	0.520
- with spring return	S9 512RF-1/4	0.520
Pneumatic, by permanent signal	S9 561RF-1/4	0.490
Pneumatic, by impulse	S9 561-1/4	0.510
- with biased position	S9 562-1/4	0.510
Electrical, by permanent signal	S9 581(S) RF-1/4	0.600
Electrical, by impulse	S9 581(S)-1/4	0.700
- with biased position	S9 582(S)-1/4	0.700

### Hand lever actuated – Type: S9 511-1/4, S9 511RF-1/4

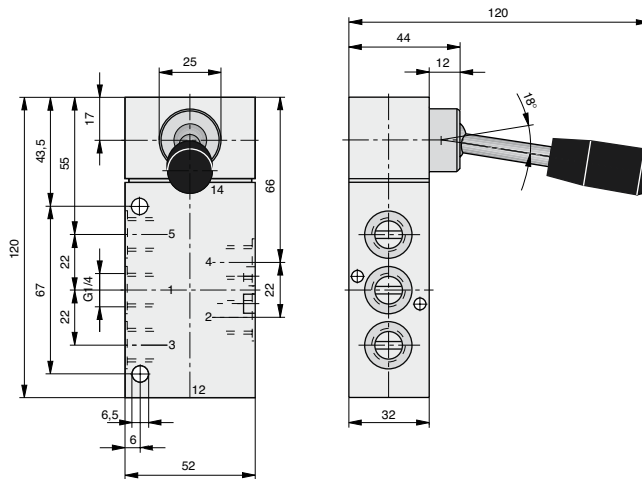

### Safety hand lever actuated – Type: S9 511S-1/4

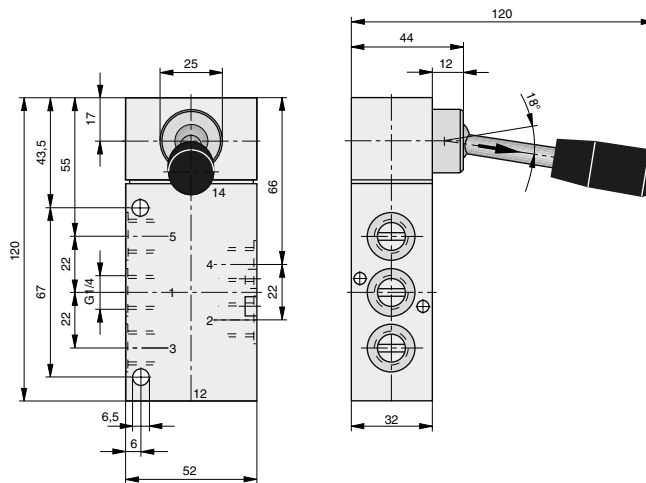

**Rotary lever actuated**  
**Type: S9 512-1/4, S9 512RF-1/4**

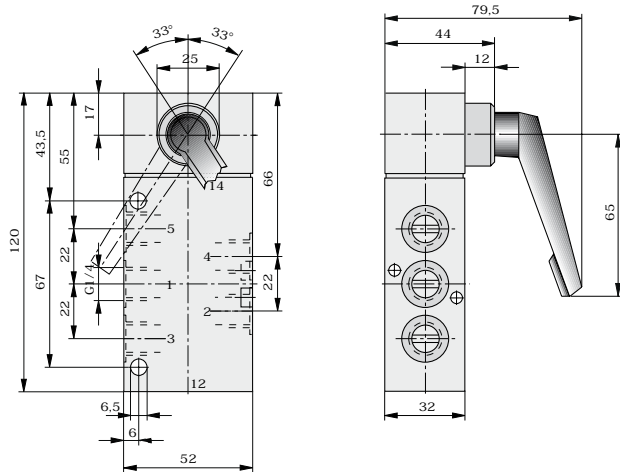

**Pneumatically actuated**  
**Type: S9 561-1/4, S9 562-1/4, S9 561RF-1/4**

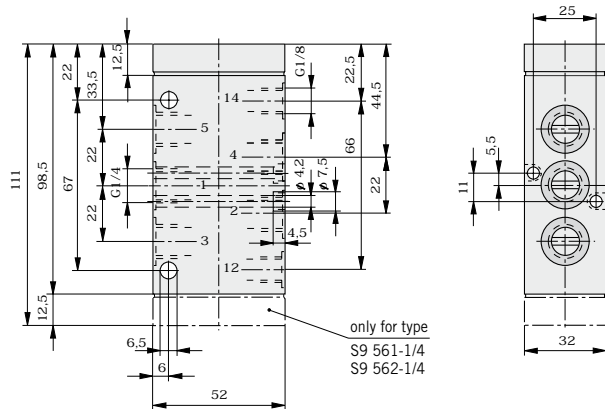

**Electrically actuated**  
**Type: S9 581(S)-1/4, S9 582(S)-1/4, S9 581(S)RF-1/4**

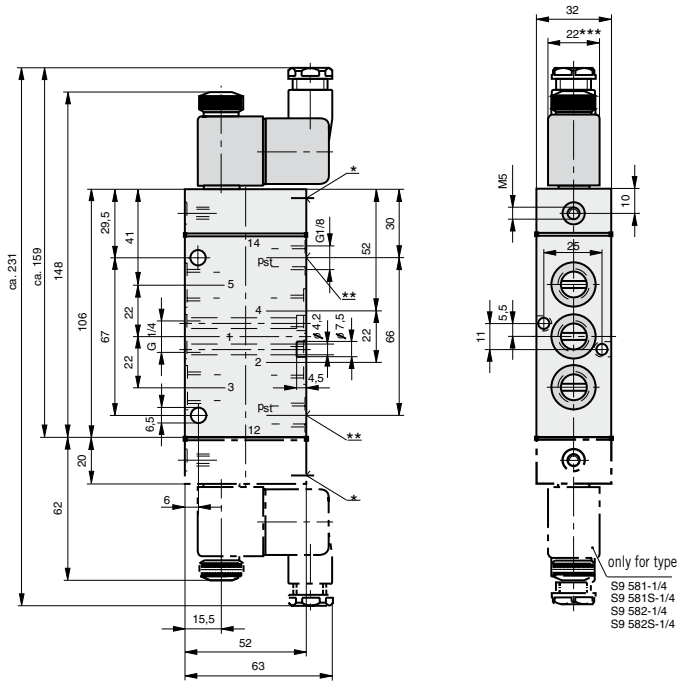

- \* Manual override
- \*\* Operating pressure supply  $p_{st}$  only for type S9 581S
- \*\*\* Solenoid width = 30 mm on low wattage coil version

**Solenoid for use in EX areas**  
**Dimensions**

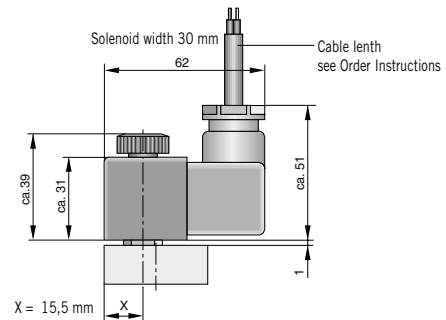

For more information on valves to ATEX standards see page 46, 47, 74

For order instructions see page 73, 74, characteristics see page 44-47

Dimensions in mm

# 5/2 Way Valves Series S9

G1/2

**Actuation systems:**

- Hand lever
- Safety hand lever
- Pneumatic
- Electrical pilot operated

**Versions:**

- With external pilot air
- With biased position
- Version to ATEX Standard

**Weight (mass) kg**

Description	Type	Weight (mass)
Hand lever, indexed	S9 511-1/2	0.120
- with spring return	S9 511RF-1/2	0.120
Safety hand lever	S9 511S-1/2	0.120
Rotary lever, indexed	S9 512-1/2	0.120
- with spring return	S9 512RF-1/2	0.120
Pneumatic, by permanent signal	S9 561RF-1/2	0.800
Pneumatic, by impulse	S9 561-1/2	0.900
- with biased position	S9 562-1/2	0.900
Electrical, by permanent signal	S9 581(S) RF-1/2	1.000
Electrical, by impulse	S9 581(S)-1/2	1.045
- with biased position	S9 582-1/2	1.045

**Hand lever actuated – Type: S9 511-1/2, S9 511RF-1/2**

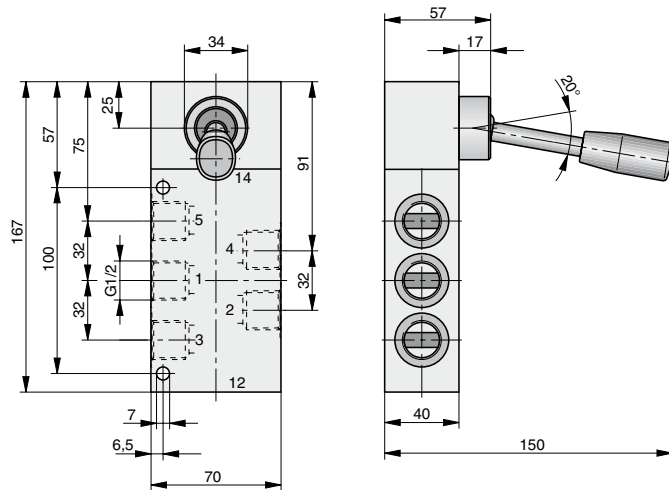

**Safety hand lever actuated – Type: S9 511S-1/2**

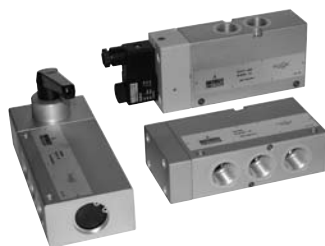
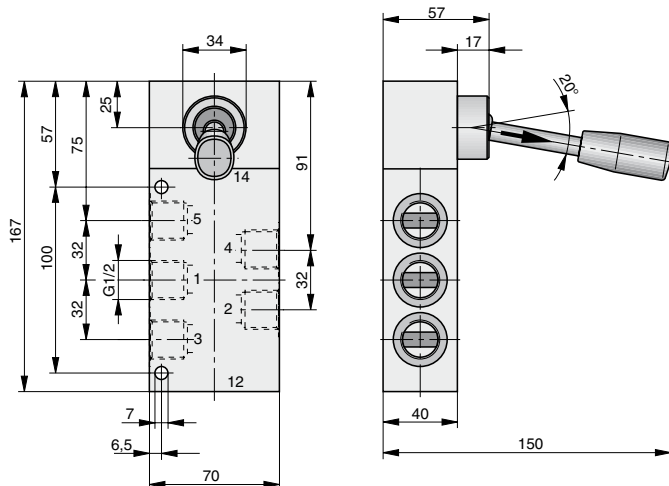



**Rotary lever actuated – Type: S9 512-1/2, S9 512RF-1/2**

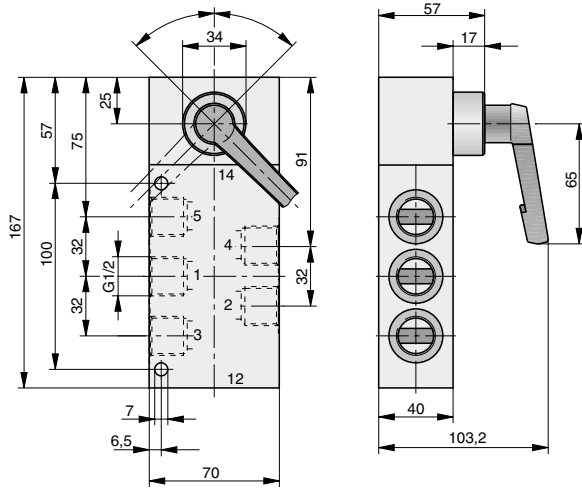

**Pneumatically actuated  
Type: S9 561-1/2, S9 561RF-1/2, S9 562-1/2**

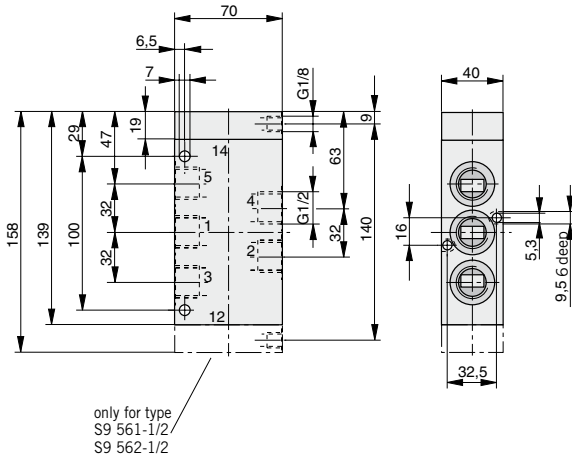

**Electrically actuated  
Type: S9 581(S)-1/2, S9 582-1/2, S9 581(S)RF-1/2**

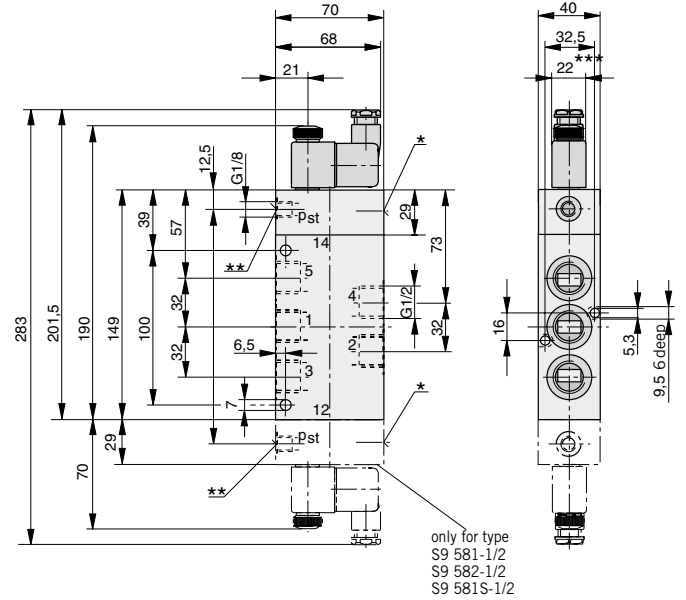

- \* Manual override
- \*\* Operating pressure supply  $p_{st}$  only for type S9 581S
- \*\*\* Solenoid width is 30 mm on low wattage coil version

**Solenoid for use in EX areas  
Dimensions**

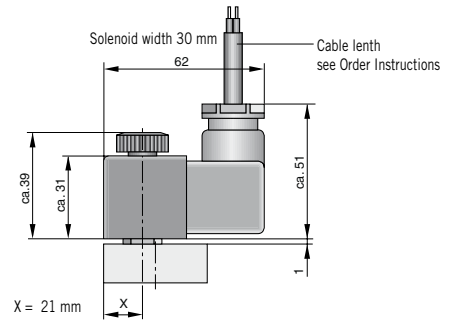

For more information on valves to ATEX standards see page 46, 47, 74

For order instructions see page 73,74, characteristics see page 44-47

Dimensions in mm

# 5/3 Way Valves Series S9

G1/8

### Actuation systems:

- Hand lever
- Safety hand lever
- Pneumatic
- Electrical pilot operated

### Versions:

- With external pilot air
- Version to ATEX Standard

### Weight (mass) kg

Description	Type *	Weight (mass)
Hand lever	S9 511.-1/8	0,195
- with spring return	S9 511RF.-1/8	0,195
Safety hand lever	S9 511S.-1/8	0,195
Pneumatic, by permanent signal	S9 561RF.-1/8	0,180
Electrical, by permanent signal	S9 581RF.-1/8	0,425
Electrical, by permanent signal	S9 581S-RF.-1/8	0,425

\* Type code for middle position functions

G = middle position closed

E = middle position exhausted

B = middle position pressurized

### Hand lever actuated – Type: S9 511.-1/8, S9 511RF.-1/8

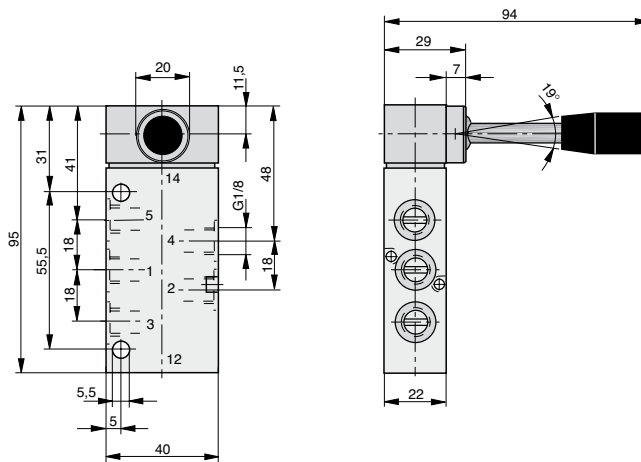

### Safety hand lever actuated – Type: S9 511S.-1/8

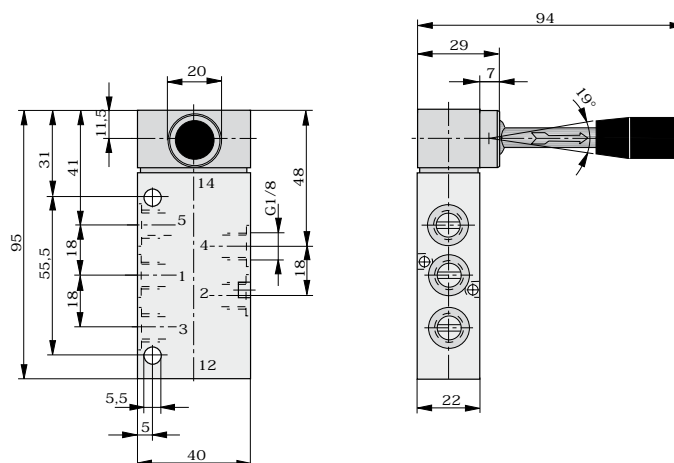

**Pneumatically actuated – Type: S9 561RF-1/8**

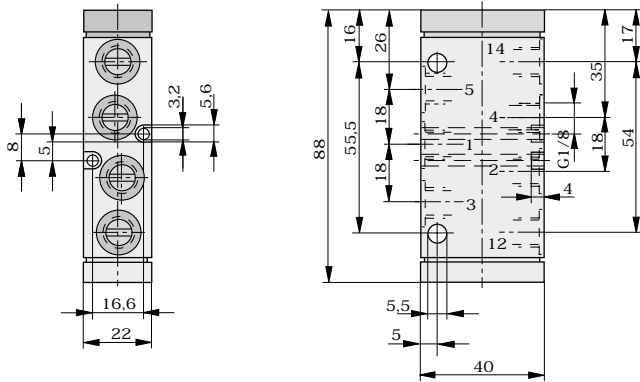

**Electrically actuated – Type: S9 581(S)-RF-1/8**

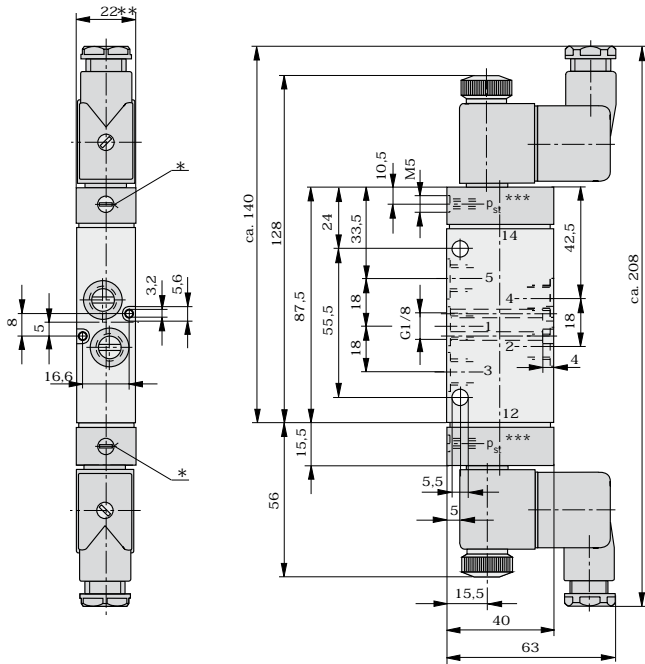

- \* Manual override
- \*\* Solenoid width = 30 mm on low wattage coil version
- \*\*\* Operating pressure supply  $p_{st}$  only for type S9 581S

**Solenoid for use in EX areas  
Dimensions**

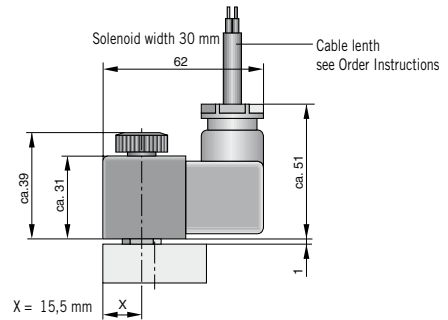

For more information on valves to ATEX standards see page 46, 47, 77

For order instructions see page 75-77, characteristics see page 44-47

Dimensions in mm

# 5/3 Way Valves Series S9

G1/4

### Actuation systems:

- Hand lever
- Safety hand lever
- Pneumatic
- Electrical pilot operated

### Versions:

- Version to ATEX Standard

### Weight (mass) kg

Description	Type *	Weight (mass)
Hand lever, indexed	S9 511.-1/4	0.520
- with spring return	S9 511RF.-1/4	0.530
Safety hand lever	S9 511S.-1/4	0.520
Rotary lever, indexed	S9 512.-1/4	0.520
-with spring return	S9 512RF.-1/4	0.530
Pneumatic, by permanent signal	S9 561RF.-1/4	0.530
Electrical, by permanent signal	S9 581RF.-1/4	0.700

\* Type code for middle position functions

G = middle position closed

E = middle position exhausted

B = middle position pressurized

### Hand lever actuated – Type: S9 511.-1/4, S9 511RF.-1/4

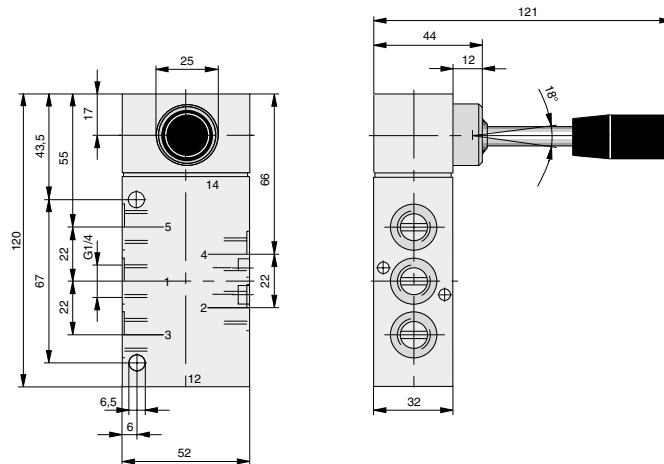

### Safety hand lever actuated – Type: S9 511S.-1/4

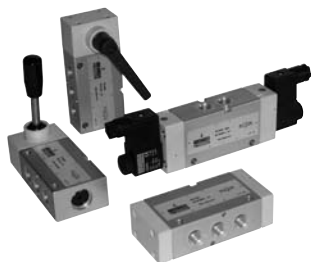
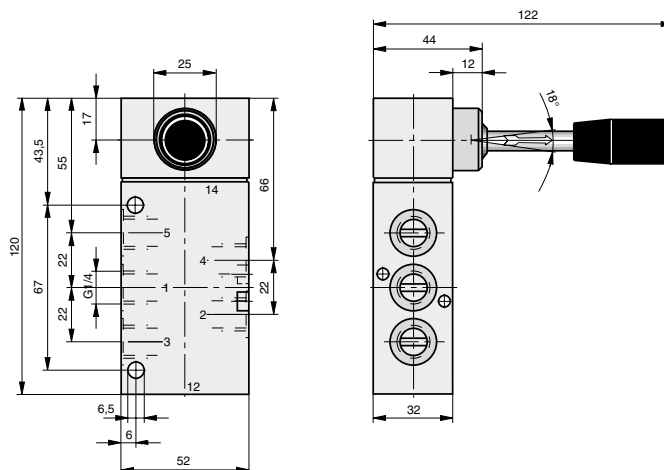

Rotary lever actuated – Type: S9 512.-1/4, S9 512RF.-1/4

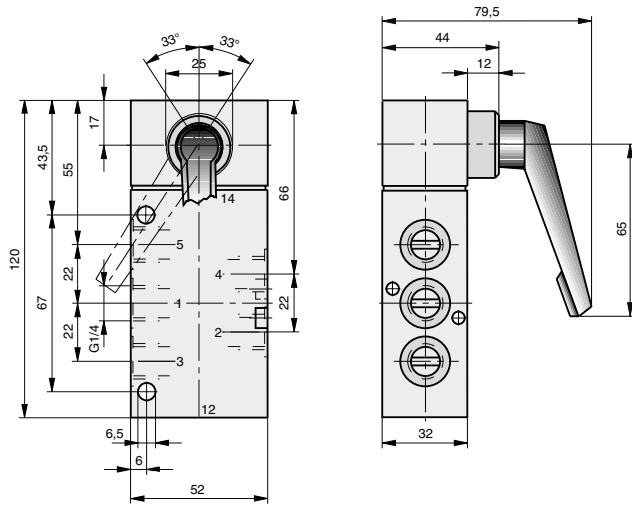

Electrically actuated – Type: S9 581RF.-1/4

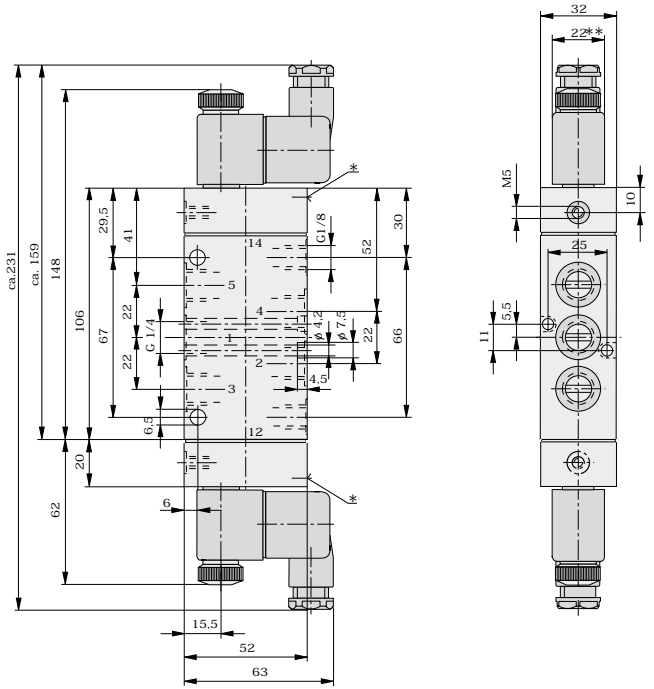

Pneumatically actuated – Type: S9 561RF.-1/4

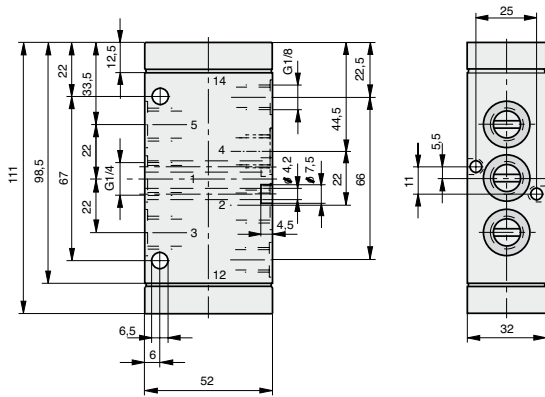

- \* Manual override
- \*\* Solenoid width is 30 mm on low wattage coil version

**Solenoid for use in EX areas  
Dimensions**

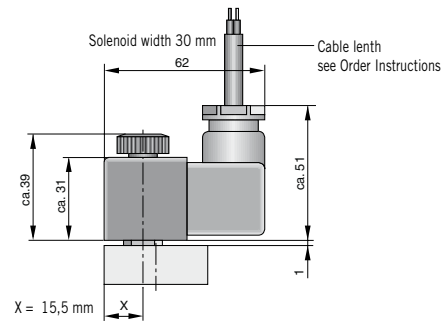

For more information on valves to ATEX standards see page 46, 47, 77

For order instructions see page 75-77, characteristics see page 44-47

Dimensions in mm

# 5/3 Way Valves Series S9

G1/2

### Actuation systems:

- Hand lever
- Safety hand lever
- Pneumatic
- Electrical pilot operated

### Versions:

- Version to ATEX Standard

### Weight (mass) kg

Description	Type *	Weight (mass)
Hand lever, indexed	S9 511.-1/2	1.200
- with spring return	S9 511RF.-1/2	1.200
Safety hand lever	S9 511S.-1/2	1.200
Rotary lever, indexed	S9 512.-1/2	1.200
- with spring return	S9 512RF.-1/2	1.200
Pneumatic, by permanent signal	S9 561RF.-1/2	0.900
Electrical, by permanent signal	S9 581RF.-1/2	1.045

\* Type code for middle position functions  
 G = middle position closed  
 E = middle position exhausted  
 B = middle position pressurized

### Hand lever actuated – Type: S9 511.-1/2, S9 511RF.-1/2

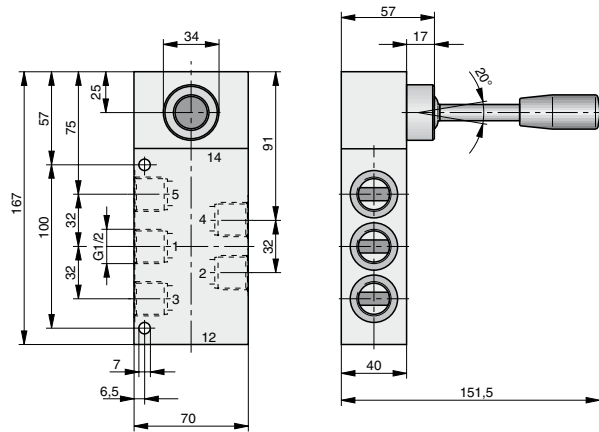

### Safety hand lever actuated – Type: S9 511S.-1/2

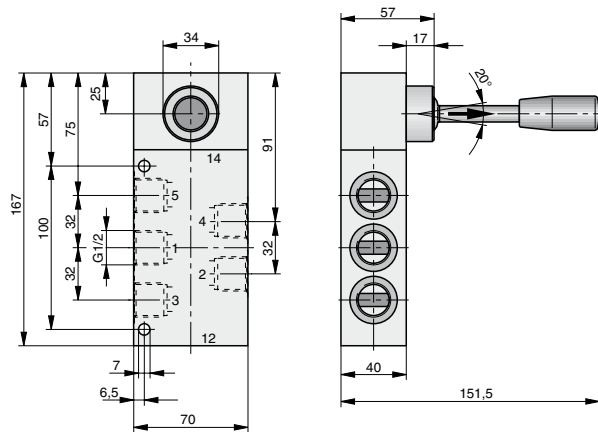

Rotary lever actuated – Type: S9 512.-1/2, S9 512RF.-1/2

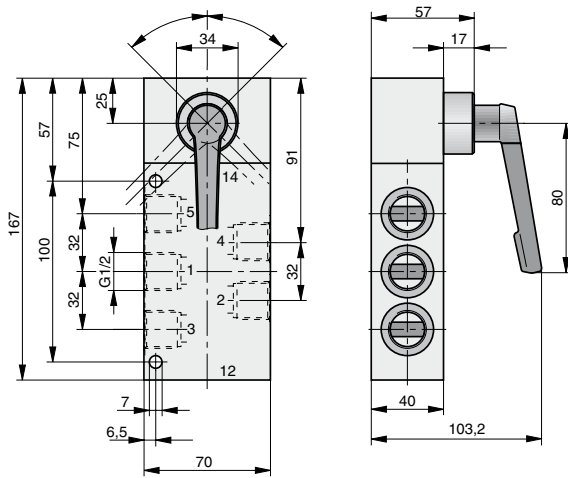

Electrically actuated – Type: S9 581RF.-1/2

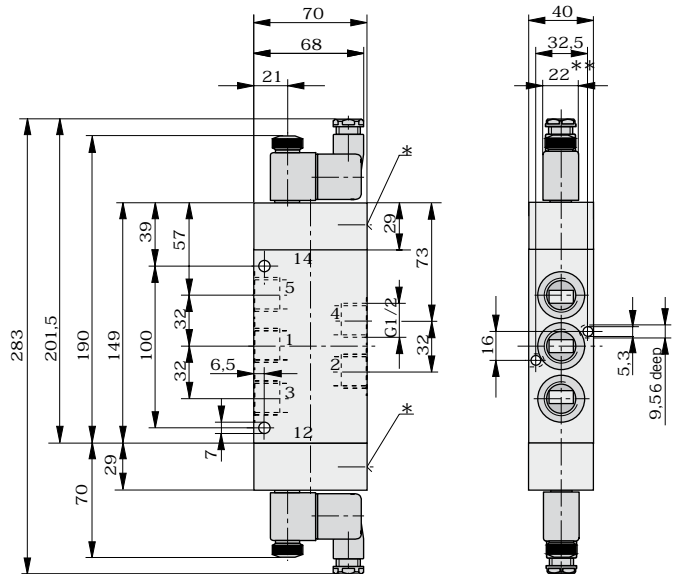

Pneumatically actuated – Type: S9 561RF.-1/2

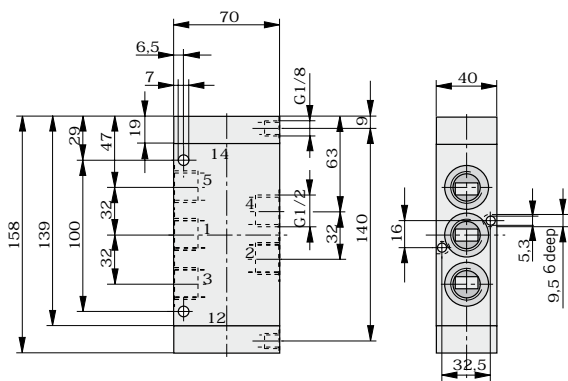

- \* Manual override
- \*\* Solenoid width is 30 mm on low wattage coil version

**Solenoid for use in EX areas  
Dimensions**

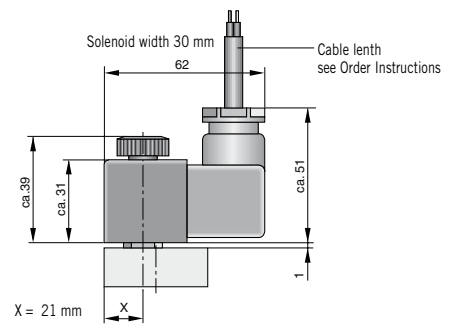





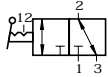
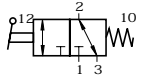
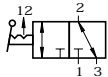
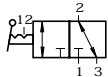
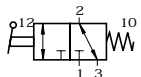
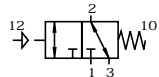
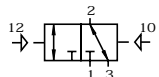
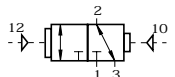
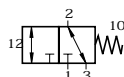

For more information on valves to ATEX standards see page 46, 47, 77

For order instructions see page 75-77, characteristics see page 44-47

Dimensions in mm

### 3/2 Way Valves – Standard versions

Actuation System	Symbol	Mounting Ø (mm)	Order Instructions		Page
			Type	Order No.	
Hand lever, indexed			S9 311-1/8	PA 10293	48
			S9 311-1/4	PA 12708	52
			S9 311-1/2	PA 16404	54
Hand lever, spring return			S9 311RF-1/8	PA 10294	48
			S9 311RF-1/4	PA 12709	52
			S9 311RF-1/2	PA 16405	54
Hand lever secured in 2 switching positions			S9 311S-1/4	PA 12710	52
			S9 311S-1/2	PA 16406	54
Rotary lever, indexed			S9 312-1/4	PA 12711	53
			S9 312-1/2	PA 16407	45
Rotary lever, spring return			S9 312RF-1/4	PA 12712	53
			S9 312RF-1/2	PA 16408	55
Pneumatic, by permanent signal			S9 361RF-1/8	PA 10295	49
			S9 361RF-1/4	PA 12713	53
			S9 361RF-1/2	PA 16409	55
Pneumatic, by impulse			S9 361-1/8	PA 10296	49
			S9 361-1/4	PA 12714	53
			S9 361-1/2	PA 16410	55
Pneumatic, by impulse, with biased position			S9 362-1/4	PA 12715	53
			S9 362-1/2	PA 16411	55
Basic valve for panel mounting			S9 390RF-1/8	PA 10307	50
Rotary lever, indexed		22	12T-22	KX 9355	50
		30	12T-30	KX 9314	
Rotary lever, spring return		22	12T-RF-22	KX 9356	51
		30	12T-RF-30	KX 9315	
Pushbutton		22	13T-RF-22	KX 9357	50
		30	13T-RF-30	KX 9316	
Mushroom pushbutton		22	15T-RF-22	KX 9358	51
		30	15T-RF-30	KX 9317	
Locking switch		22	16T-22	KX 9359	51
		30	16T-30	KX 9318	



Actuation System	Symbol	Mounting Ø (mm)	Order Instructions		Page	
			Type	Order No.		
Rotary switch		22	17T-22	KX 9360	51	
		30	17T-30	KX 9319		
Mushroom pushbutton emergency-Off		22	18T-22	KX 9361	51	
		30	18T-30	KX 9320		
Electrical by permanent signal			S9 381RF-1/8-NC-..	PA 10297-..33	49	
			S9 381RF-1/4-NC-..	PA 12716-..33	53	
			S9 381RF-1/2-NC-..	PA 16412-..33	55	
	with external pilot air			S9 381RF-1/8-NO-..	PA 10298-..33	49
				S9 381RF-1/4-NO-..	PA 12717-..33	53
				S9 381RF-1/2-NO-..	PA 16413-..33	55
Electrical by impulse			S9 381S-RF-1/8-..	PA 10300-..33	49	
			S9 381S-RF-1/4-..	PA 12719-..33	53	
			S9 381S-RF-1/2-..	PA 16415-..33	55	
Electrical, by impulse, with external pilot air			S9 381S-1/8-..	PA 10301-..33	49	
			S9 381S-1/4-..	PA 12720-..33	53	
			S9 381S-1/2-..	PA 16417-..33	55	
Electrical by impulse, with biased position			S9 382-1/4-..	PA 12721-..33	53	
			S9 382-1/2-..	PA 16418-..33	55	
	with external pilot air			S9 382S-1/4-..	PA 12722-..33	53
			S9 382S-1/2-..	PA 16419-..33	55	

Solenoid version	Nominal voltage	Applicable for	Key code	ATEX Type additon
Standard version	230V 50/60Hz	110 V =	61	-
	24V =	60V 50/60Hz	02	-
Low wattage version	24V =		13	-
	230V 50/60Hz		69	-
EX Area versions to ATEX standard see page 72				

**EX Area versions to ATEX Standard****Category, type of ignition protection**

Single valve: Ⓢ II 2G c T4 T135°C -10°C≤Ta≤+60°C

Solenoid/individual use: Ⓢ II 2G EEx m II T5 -20°C≤Ta≤+50°C

Solenoid/manifold mounting: Ⓢ II 2G EEx m II T5 -20°C≤Ta≤+40°C

Solenoid version	Nominal voltage	Applicable for	Key code	ATEX Type additon
Solenoid	24V =		48	ATEX
– with cable 1.2 m				
– with cable 3 m	24V =		45	ATEX
– with cable 5 m	24V =		46	ATEX
– with cable 10 m	24V =		47	ATEX
– with cable 1.2 m	24V 50/60Hz		99	ATEX
– with cable 1.2 m	110V 50/60Hz		97	ATEX
– with cable 1.2 m	230V 50/60Hz		98	ATEX

**Example for valves in ATEX-Version:**

– for valves Series S9-G1/8, S9-G1/4, S9-G1/2

Please add behind the Standard Order No. "ATEX"

**Type: S9 381RF-1/8-NC-4633****Order No. PA10297-4633ATEX**

### Order Instructions – 5/2 Way Valves – Standard versions

Actuation System	Symbol	Mounting Ø (mm)	Order Instructions		Page
			Type	Order No.	
Hand lever, indexed			S9 511-1/8	PA 10308	56
			S9 511-1/4	PA 12671	60
			S9 511-1/2	PA 16367	62
Hand lever, spring return			S9 511RF-1/8	PA 10309	56
			S9 511RF-1/4	PA 12672	60
			S9 511RF-1/2	PA 16366	62
Hand lever secured in 2 switching positions			S9 511S-1/8	PA 10368	57
			S9 511S-1/4	PA 12673	60
			S9 511S-1/2	PA 16368	62
Rotary lever, indexed			S9 512-1/4	PA 12674	61
			S9 512-1/2	PA 16378	63
Rotary lever, spring return			S9 512RF-1/4	PA 12675	61
			S9 512RF-1/2	PA 16379	63
Pneumatic, by permanent signal			S9 561RF-1/8	PA 10310	57
			S9 561RF-1/4	PA 12676	61
			S9 561RF-1/2	PA 16165	63
Pneumatic, by impulse			S9 561-1/8	PA 10311	57
			S9 561-1/4	PA 12677	61
			S9 561-1/2	PA 16166	63
Pneumatic, by impulse, with biased position			S9 562-1/4	PA 12678	61
			S9 562-1/2	PA 16167	63
Basic valve for panel mounting			S9 590RF-1/8	PA 10320	58
Rotary lever, indexed		22	12T-22	KX 9355	58
		30	12T-30	KX 9314	
Rotary lever, spring return		22	12T-RF-22	KX 9356	59
		30	12T-RF-30	KX 9315	
Pushbutton		22	13T-RF-22	KX 9357	58
		30	13T-RF-30	KX 9316	
Mushroom pushbutton		22	15T-RF-22	KX 9358	58
		30	15T-RF-30	KX 9317	
Locking switch		22	16T-22	KX 9359	59
		30	16T-30	KX 9318	

### Order Instructions – 5/2 Way Valves – Standard versions

Actuation System	Symbol	Mounting Ø (mm)	Order Instructions		Page
			Type	Order No.	
Rotary switch		22	17T-22	KX 9360	58
		30	17T-30	KX 9319	
Mushroom pushbutton Emergency-Off		22	18T-22	KX 9361	59
		30	18T-30	KX 9320	
Electrical, by permanent signal			S9 581RF-1/8-..	PA 10312-..33	57
			S9 581RF-1/4-..	PA 12679-..33	61
			S9 581RF-1/2-..	PA 16171-..33	63
with external pilot air			S9 581S-RF-1/8-..	PA 10314-..33	57
			S9 581S-RF-1/4-..	PA 12681-..33	61
			S9 581S-RF-1/2-..	PA 16174-..33	63
Electrical, by impulse			S9 581-1/8-..	PA 10313-..33	57
			S9 581-1/4-..	PA 12680-..33	61
			S9 581-1/2-..	PA 16172-..33	63
with external pilot air			S9 581S-1/8-..	PA 10315-..33	57
			S9 581S-1/4-..	PA 12682-..33	61
			S9 581S-1/2-..	PA 16175-..33	63

Solenoid version	Nominal voltage	Applicable for	Key code	ATEX Type additon
Standard version	230V 50/60Hz	110 V =	61	-
	24V =	60V 50/60Hz	02	-
Low wattage version	24V =		13	-
	230V 50/60Hz		69	-

#### EX Area versions to ATEX Standard

##### Category, type of ignition protection

Single valve: Ⓜ II 2G c T4 T135°C -10°C ≤ Ta ≤ +60°C

Solenoid/individual use: Ⓜ II 2G EEx m II T5 -20°C ≤ Ta ≤ +50°C

Solenoid/manifold mounting: Ⓜ II 2G EEx m II T5 -20°C ≤ Ta ≤ +40°C

Solenoid version	Nominal voltage	Applicable for	Key code	ATEX Type additon
Solenoid	24V =		48	ATEX
- with cable 1.2 m	24V =		45	ATEX
- with cable 3 m	24V =		46	ATEX
- with cable 5 m	24V =		47	ATEX
- with cable 10 m	24V =		99	ATEX
- with cable 1.2 m	24V 50/60Hz		97	ATEX
- with cable 1.2 m	110V 50/60Hz		98	ATEX
- with cable 1.2 m	230V 50/60Hz			ATEX

#### Example for valves in ATEX-Version:

- for valves Series S9-G1/8, S9-G1/4, S9-G1/2

Please add behind the Standard Order No. "ATEX"

**Type: S9 581RF-1/8-4633**

**Order No. PA10312-4633ATEX**

**Order Instructions – 5/3 Way Valves – Standard versions**

Actuation System	Symbol	Order Instructions		Page
		Type	Order No.	
Hand lever, secured in 3 operating positions		S9 511G-1/8	PA 10321	64
		S9 511G-1/4	PA 12687	66
		S9 511G-1/2	PA 16369	68
		S9 511E-1/8	PA 10322	64
		S9 511E-1/4	PA 12688	66
		S9 511E-1/2	PA 16370	68
		S9 511B-1/8	PA 10323	64
		S9 511B-1/4	PA 12689	66
		S9 511B-1/2	PA 16371	68
Hand lever, spring return to middle position		S9 511RFG-1/8	PA 10324	64
		S9 511RFG-1/4	PA 12690	66
		S9 511RFG-1/2	PA 16372	68
		S9 511RFE-1/8	PA 10325	64
		S9 511RFE-1/4	PA 12691	66
		S9 511RFE-1/2	PA 16373	68
		S9 511RFB-1/8	PA 10326	64
		S9 511RFB-1/4	PA 12692	66
		S9 511RFB-1/2	PA 16374	68
Hand lever, secured in 3 operating positions		S9 511SG-1/8	PA 10327	64
		S9 511SG-1/4	PA 12693	66
		S9 511SG-1/2	PA 16375	68
		S9 511SE-1/8	PA 10328	64
		S9 511SE-1/4	PA 12694	66
		S9 511SE-1/2	PA 16376	68
		S9 511SB-1/8	PA 10329	64
		S9 511SB-1/4	PA 12695	66
		S9 511SB-1/2	PA 16377	68
Rotary lever, indexed in 3 operating positions		S9 512G-1/4	PA 12696	67
		S9 512G-1/2	PA 16380	69
		S9 512E-1/4	PA 12697	67
		S9 512E-1/2	PA 16381	69
		S9 512B-1/4	PA 12698	67
		S9 512B-1/2	PA 16382	69

Actuation System	Symbol	Order Instructions		Page	
		Type	Order No.		
Rotary lever, spring return to middle position		S9 512RFG-1/4	PA 12699	67	
		S9 512RFG-1/2	PA 16383	69	
		S9 512RFE-1/4	PA 12700	67	
		S9 512RFE-1/2	PA 16384	69	
		S9 512RFB-1/4	PA 12701	67	
		S9 512RFB-1/2	PA 16385	69	
Pneumatic, by permanent signal		S9 561RFG-1/8	PA 10330	65	
		S9 561RFG-1/4	PA 12702	67	
		S9 561RFG-1/2	PA 16168	69	
	spring return to middle position		S9 561RFE-1/8	PA 10331	65
			S9 561RFE-1/4	PA 12703	67
			S9 561RFE-1/2	PA 16169	69
		S9 561RFB-1/8	PA 10332	65	
		S9 561RFB-1/4	PA 12704	67	
		S9 561RFB-1/2	PA 16170	69	
Electrical by permanent signal		S9 581RFG-1/8-..	PA 10333-..33	65	
		S9 581RFG-1/4-..	PA 12705-..33	67	
		S9 581RFG-1/2-..	PA 16176-..33	69	
	spring return to middle position		S9 581RFE-1/8-..	PA 10334-..33	65
			S9 581RFE-1/4-..	PA 12706-..33	67
			S9 581RFE-1/2-..	PA 16177-..33	69
		S9 581RFB-1/8-..	PA 10335-..33	65	
		S9 581RFB-1/4-..	PA 12707-..33	67	
		S9 581RFB-1/2-..	PA 16178-..33	69	

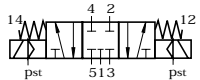
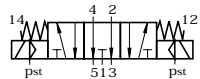
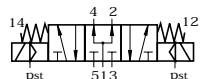

For complete Type- and Order No. - see page 77

Actuation System	Symbol	Order Instructions		Page
		Type	Order No.	
Electrical by permanent signal		S9 581S-RFG-1/8-..	PA 10377-..33	65
		S9 581S-RFG-1/4-..	PA 12925-..33	67
spring return to middle position		S9 581S-RFE-1/8-..	PA 10379-..33	65
		S9 581S-RFE-1/4-..	PA 12923-..33	67
with external pilot air		S9 581S-RFB-1/8-..	PA 10378-..33	65
		S9 581S-RFB-1/4-..	PA 12924-..33	67

Solenoid version	Nominal voltage	Applicable for	Key code	ATEX Type additon
Standard version	230V 50/60Hz	110 V =	61	-
	24V =	60V 50/60Hz	02	-
Low wattage version	24V =		13	-
	230V 50/60Hz		69	-

#### EX Area versions to ATEX Standard

##### Category, type of ignition protection

Single valve: Ⓜ II 2G c T4 T135°C -10°C ≤ Ta ≤ +60°C

Solenoid/individual use: Ⓜ II 2G EEx m II T5 -20°C ≤ Ta ≤ +50°C

Solenoid/manifold mounting: Ⓜ II 2G EEx m II T5 -20°C ≤ Ta ≤ +40°C

Solenoid version	Nominal voltage	Applicable for	Key code	ATEX Type additon
Solenoid	24V =		48	ATEX
- with cable 1.2 m				
- with cable 3 m	24V =		45	ATEX
- with cable 5 m	24V =		46	ATEX
- with cable 10 m	24V =		47	ATEX
- with cable 1.2 m	24V 50/60Hz		99	ATEX
- with cable 1.2 m	110V 50/60Hz		97	ATEX
- with cable 1.2 m	230V 50/60Hz		98	ATEX

##### Example for valves in ATEX-Version:

- for valves Series S9-G1/8, S9-G1/4, S9-G1/2

Please add behind the Standard Order No. "ATEX"

**Type: S9 581RFG-1/8-4633**

**Order No. PA10333-4633ATEX**

# 3/2, 5/2 and 5/3 Way Valves Series S9

G1/8, G1/4

### Actuation systems:

#### Pneumatic

- AND
- OR
- TIMER

### Versions:

- Freely selectable types
- See Order information
- All Timer-Versions on request

### Weight (mass) kg

Description	Weight (mass) – Connection size	
	G1/8	G1/4
3/2 Way Valve, by permanent signal	0.137	0.370
3/2 Way Valve, by impulse	0.147	0.430
5/2 Way Valve, by permanent signal	0.160	0.490
5/2 Way Valve, by impulse	0.170	0.510
5/3 Way Valve, by permanent signal	0.180	0.530

### Possible combinations:

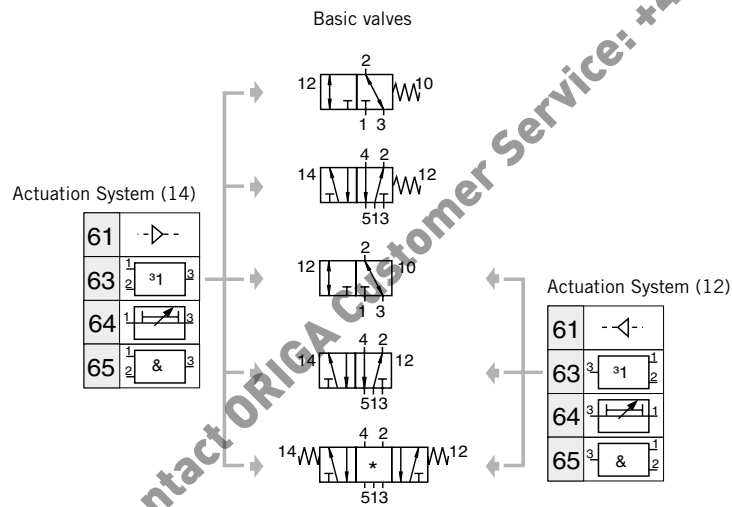

For more information on standard valves see Instructions sheets on page 44-69

- \* RFG = middle position closed
- RFE = middle position exhausted
- RFB = middle position pressurized



Dimensions in mm



**Valve Combinations with Logic Elements – 3/2, 5/2 and 5/3 Way Valves**

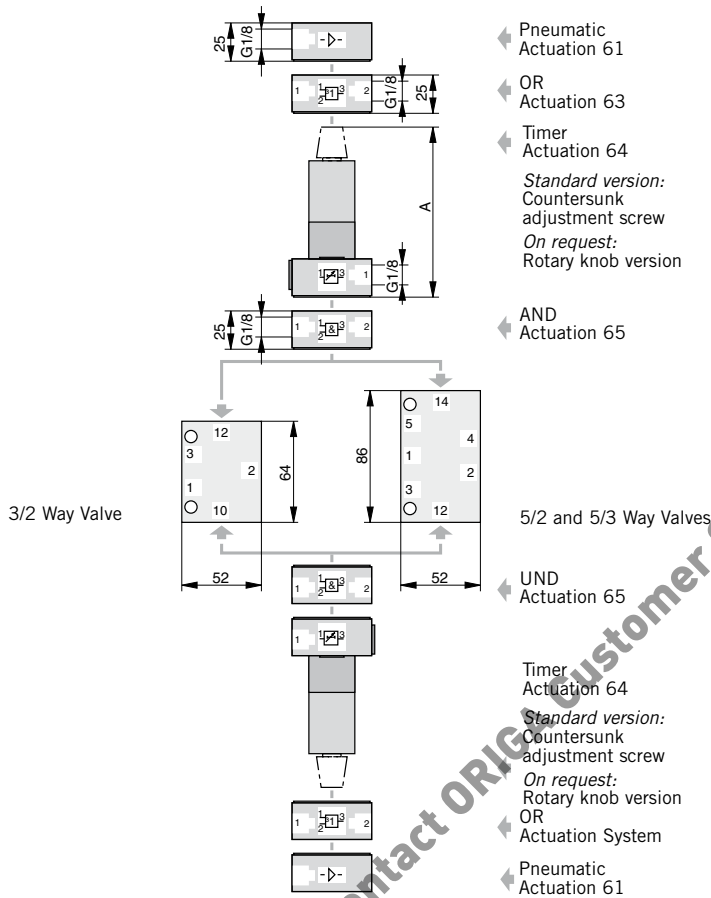

Dimension Table and adjustment ranges

Adjustment range	Dimension A [mm]
0.1 to 15	103 (133*)
0.1 to 30	117 (147*)
0.1 to 60	150 (180*)

\* Version with rotary knob (optional)

Dimension Table and adjustment ranges

Adjustment range	Dimension A [mm]
0.1 to 15	103 (133*)
0.1 to 30	117 (147*)
0.1 to 60	150 (180*)

\* Version with rotary knob (optional)

**Order Instructions**



Version	
3	3 Way Valve
5	5 Way Valve

Actuation System (14)	
61	Pneumatic
63	OR
64	Timer* – all Timer-Versions on request
65	AND

\* only with connection size G1/4

Connection size	
1/8	G1/8
1/4	G1/4

Mid position function (only with 5/3 Way Valves)	
RFG	closed
RFE	vented
RFB	pressurized

Actuation System (14)	
RF	spring return
61	pneumatic
63	OR
64	Timer* – all Timer-Versions on request
65	AND

\* only with Connection size G1/4

Dimensions in mm



## Contents

Version	Actuation	Page		
		Characteristics	Dimensions	Order Instructions Overview
3/2 Way Valves Series EV-M5 (G1/8)	electrical	82	83	83
3/2 Way Valves Series V9-G1/8	electrical	84	85	86

## Solenoid Poppet Valves

*directly actuated*

*Series EV-M5 (G1/8)*

*Series V9-G1/8*



# 3/2 Way Screw-In Valve Series EV

G1/8-M5

**Actuation System:**  
– Electrical, directly actuated

## Characteristics – Series EV

Characteristics	Symbol	Unit	Description	
<b>General Features</b>				
Actuation			Electrical directly operated	
Type			Poppet valve, normally closed	
Mounting			Screws into thread G1/8	
Tube connection			Thread	
Port size			Port 1: M5, port 2: G1/8	
Weight		kg	0.1	
Nominal diameter		mm	1	
Installation			in any position	
Ambient temperature range	$T_{min. / max.}$	°C	-10 to +60	Note : Please consult us for operating temperatures below 0° C
Medium temperature range	$T_{min. / max.}$	°C	-10 to +60	
Medium			Filtered compressed air (30µ)	
Lubrication			With or without oil mist lubrication (We recommend the use of mineral oil type VG 32 to ISO 3448)	
<b>Pneumatic Characteristics</b>				
Nominal pressure	$p_{min. / max.}$	bar	6	
Operating pressure range	$p_{min. / max.}$	bar	0 – 10	
Nominal flow	$Q_N$	l/min	30	
<b>Actuation</b>				
Electrical			Direct	
Voltage type			Alternating current (50/60Hz)	Direct current
Nominal voltage <sup>(1)</sup>				
– Standard version	$U_n$	V	230 ±10%	24 ±10% other voltages on request
– Low wattage version	$U_n$	V	230 ±10%	24 ±10%
<b>Initial power consumption</b>				
– Standard version		VA (W)	11	4.8
– Low wattage version		VA (W)	7.8	2.7
<b>Continuous consumption</b>				
– Standard version		VA (W)	8.5	4.8
– Low wattage version		VA (W)	4.9	2.7
Duty cycle	ED	%	100	
Electrical protection			IP 65 to DIN 40050 (applies only to solenoid with plug)	
Connection			Plug to DIN EN 175301-803 form B – industrial standard, Low wattage version form A	

<sup>(1)</sup> see Order Instructions



**3/2 Way Valve – Type: EV 381RF-M5**

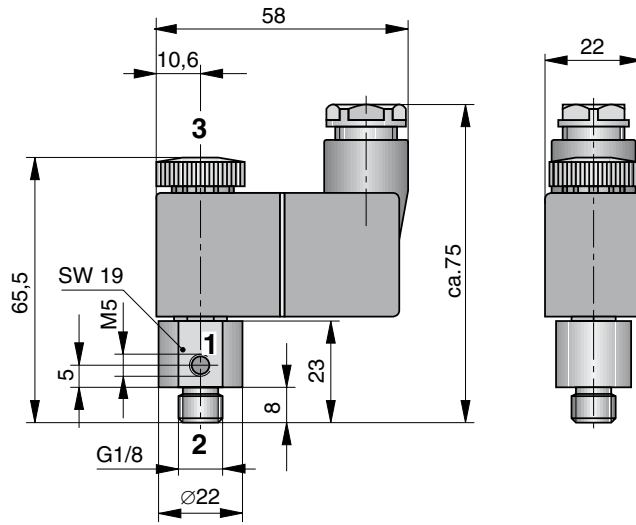

**Order Instructions – 3/2 Way Screw-In Valve – Series EV**

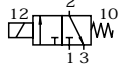
Actuation	Symbol	Order Instructions	
		Type	Order No.
Electrical, by permanent signal		EV 381RF-M5-..	PD25076-...33

Solenoid version	Nominal voltage	Key code
Cast encapsulated housing	24V =	02
	230V 50/60Hz	61
	Other voltages on request	

Dimensions in mm

# 3/2 Way Valves Series V9

NW 1.3 and 2.5

**Actuation System:**  
– Electrically actuated,  
directly actuated

**Versions:**  
Threaded version  
– Normally closed  
– Normally open  
– With manual override

**P-moulding mounting:**  
– See Order Instructions



## Characteristics – Series V9-G1/8

Characteristics	Symbol	Unit	Description		
General Features					
Type			Poppet valve		
Mounting			2 Screws M3 (NW 2.5: 2 x M4)		
Tube connection			Thread		
Thread			G1/8 – 8 deep		
Weight		kg	NW 1.3: 0.140 NW 2.5: 0.320		
Installation			In any position		
Ambient temperature range (1)	T <sub>min. / max.</sub>	°C	-10 +60	Note : Please consult us for operating temperatures below 0° C	
Medium temperature range (1)	T <sub>min. / max.</sub>	°C	-10 +70		
Medium			Filtered compressed air		
Lubrication			With or without oil mist lubrication (We recommend the use of mineral oil type VG 32 to ISO 3448)		
Pneumatic Characteristics					
Nominal pressure	p <sub>min. / max.</sub>	bar	6		
Operating pressure range	p <sub>min. / max.</sub>	bar	NW 1.3: 0–10 NW 2.5: 0-7		
Nominal flow	Q <sub>N</sub>	l/min	NW 1.3: 37 NW 2.5: 150		
Actuation					
Electrical			Direct		
Voltage type			Alternating current (50/60Hz)	Direct current	
Nominal voltage					
– Standard version	U <sub>n</sub>	V	230 ±10%	24 ±10%	other voltages on request
– Low wattage version	U <sub>n</sub>	V	230 ±10% (not for V9-NW 2.5)	24 ±10% (not for V9-NW 2.5)	
Initial power consumption					
– Standard version		VA (W)	NW 1.3: 11 NW 2.5: 11.5	NW 1.3: 4.8 NW 2.5: 10	
– Low wattage version		VA (W)	7.8	2.7	
Continuous consumption					
– Standard version		VA (W)	NW 1.3: 8.5 NW 2.5: 7.5	NW 1.3: 4.8 NW 2.5: 7.5	
– Low wattage version		VA (W)	4.9	2.7	
Duty cycle	ED	%	100		
Electrical protection		IP	IP 65 to DIN 40050 (applies only to solenoid with connector)		
Connection			NW 1.3: connector to DIN EN 175301-803 form B – industrial standard NW 2.5: connector to DIN EN 175301-803 form A – industrial standard		

Type: V9 381RF-1/8NG (NO<sup>1</sup>)– NW 1.3  
 Type: V9 381H-RF-1/8NG (NO<sup>1</sup>)– NW 1.3

<sup>1</sup> not suitable for P-supply manifold mounting

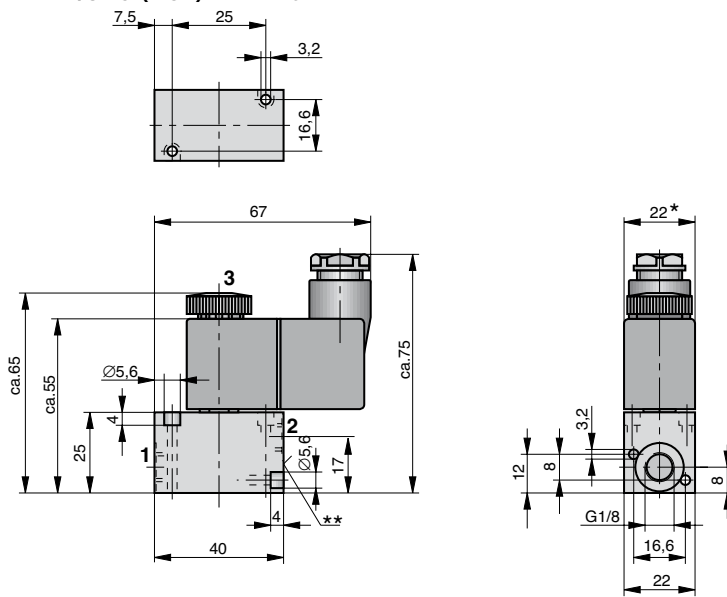

\* Low wattage version is 30 mm wide:  
 – therefore to mount these on a P-Supply Manifold, special measures are needed.  
 \*\* Manual override

Type: V9 381RF-1/8NG – NW 2.5  
 Type: V9 381H-RF-1/8NG – NW 2.5

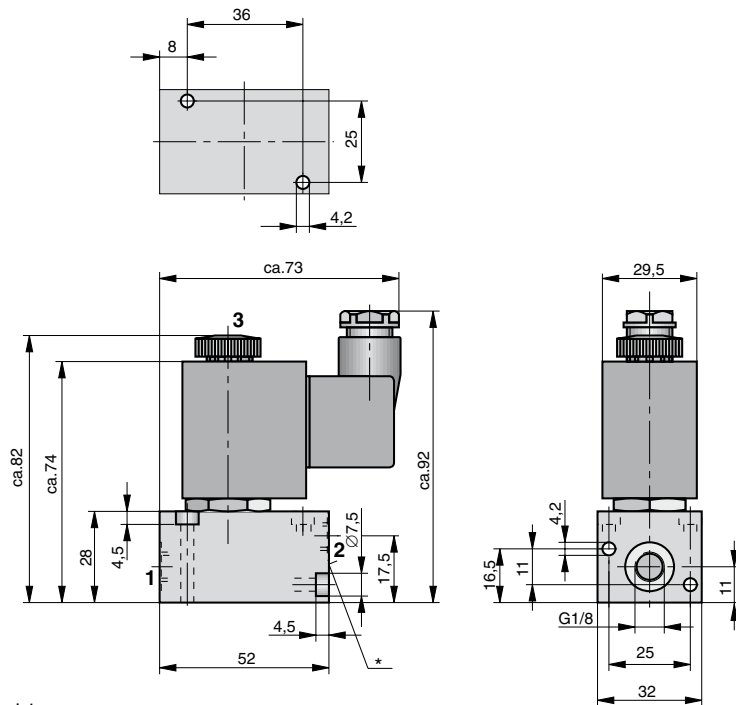

\* Manual override

For order instructions see page 86

Dimensions in mm

**Order Instructions – 3/2 Way Valves – Series V9**

Actuation System	Symbol	Nominal Size (mm)	Order Instructions		Page
			Type	Order No.	
Electrical, by permanent signal		NW 1.3	V9 381RF-1/8-NC-..	PA 10362-..33	84, 85
		NW 2.5	V9 381RF-1/8-NC-..	PA 10369-..33	84, 85
		NW 1.3	V9 381H-RF-1/8-NC-..	PA 10363-..33	84, 85
		NW 2.5	V9 381H-RF-1/8-NC-..	PA 10370-..33	84, 85
		NW 1.3	V9 381H-RF-1/8-NO-..	PA 10367-..33	84, 85

Solenoid version	Nominal voltage	Applicable for	Key code
Standard version	230V 50/60Hz	110 V =	61
	24V =	60V 50/60Hz	02
Low wattage version	24V =		13
	230V 50/60Hz		69
Other voltages on request			

**Order Instructions – Accessories for P-Supply Manifold Mounting**

Description	for NW	Order No.
P-Manifold PL-1/8-..	1.3	PD32763-....*
P-Manifold PLK-1/8-..	1.3	PD37174-....*
P-Manifold PL-1/4-..	2.5	PD32765-....*
P-Manifold PLK-1/4-..	2.5	PD32175-....*

\* Complete order no. with no. of valve

The delivery includes:

P-Manifold complete incl. mounting kit



## Contents

Version	Actuating electrical over	Page		
		Characteristics	Dimension Table	Order Instructions
Valve Islands with Multipole Connector	Sub-D plug industrial connector	88	89, 90	91
Accessories		–	–	92

## Valve Islands

*Series IM20-G1/8*

*Series IM20-G1/4*

Not for new design - Please contact ORIGA Customer Service: +49 1805 432 777

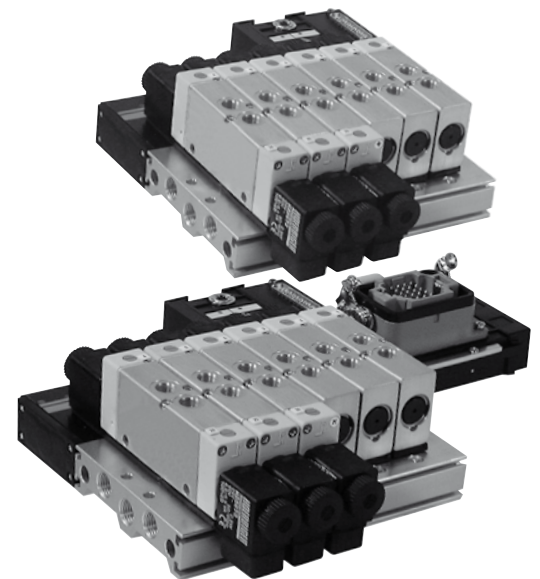

### Valve Islands with Multipole Connector

Characteristics	Symbol	Unit	Description
General Features			
Type			IM20-1/8 IM20-1/4
Mounting			4 Screws – see drawing 4 Screws – see drawing
Connection size			
– air supply and exhaust			G1/4 both sides G3/8 both sides
– valve outlets			G1/8 G1/4
Size for valve positions			22 33
Installation			In any position
Ambient and medium temperature range	$T_{min}$ $T_{max}$	°C °C	–10 +50 Note: Please consult us for operating temperatures below 0° C
Medium			Filtered compressed air
Lubrication			With or without oil mist lubrication (We recommend the use of mineral oil type VG 32 to ISO 3448)
Material			
– Base plate			Al
– Valve housing			Al
– Seals			NBR
Durability of valves			10 x 10 <sup>6</sup> operations
No. of valves positions			4 – 6 – 8 – 10 – 12 – 14 – 16 <sup>(1)</sup>
No. of switching outputs			max. 24
No. of sensor inputs			max. 32
Pneumatic characteristics			
Nominal pressure	$p_n$	bar	6
Operating pressure range	$p_{min}$	bar	2.5
	$p_{max}$	bar	10
Nominal flow	$Q_n$	l/min	500 1300 <sup>(2)</sup>
Actuation			
Electrical			By control system
Voltage type			Direct current
Nominal voltage	$U_n$	V	24 ±10%
Power consumption		W	2.5
Mass/ground			Minuspol
Electrical protection		IP	IP65 (applies only to the electrically part)
– Input clamps		IP	IP20
– Input plug		IP	IP65
Connection			
– Multipole Connector			25-pin sub-D connector or 24-pin industrial connector
– Sensor inputs			Ladder clamps or M8 x 14-pin connectors
Status indication			LED
Protective circuit			Integrated

<sup>(1)</sup> other numbers of valves can be fitted via the use of blanking plates.

<sup>(2)</sup> Version “middle position vented” 1000 l/min

**Multipole Island with sub-D-multipole connector 25pole (or heavy industrial connector) and 16 M8 4-pin feedback inputs with 44pin sub-D connector**

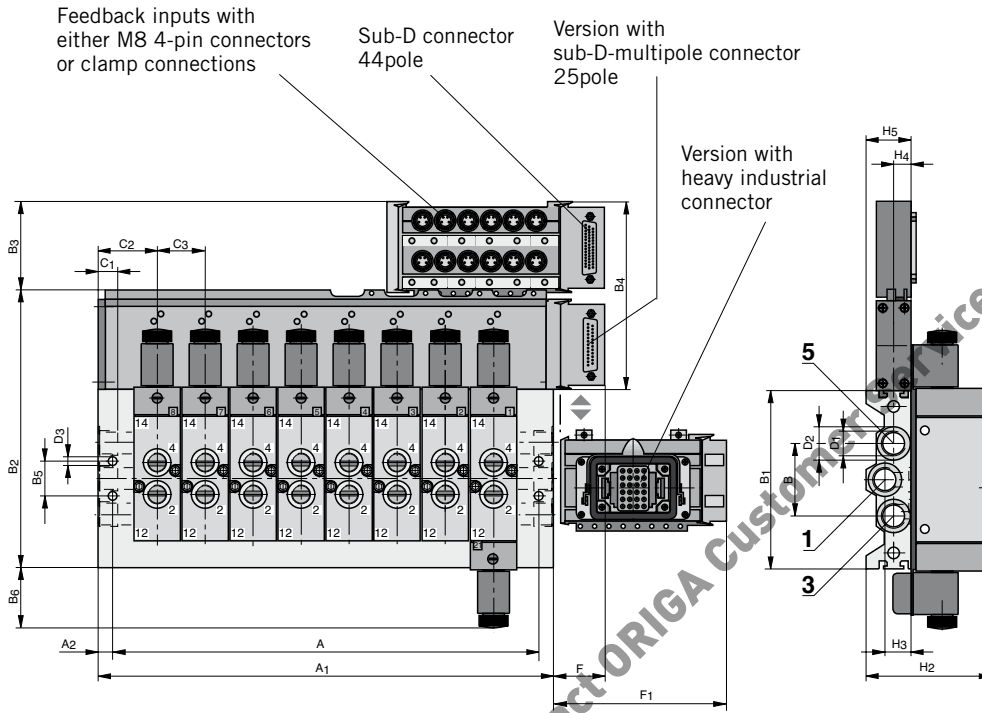

**Dimension Table (mm)**

Valve Islands	Dimension											
	A	A <sub>1</sub>	A <sub>2</sub>	B	B <sub>1</sub>	B <sub>2</sub>	B <sub>3</sub>	B <sub>4</sub>	B <sub>5</sub>	B <sub>6</sub>	B <sub>7</sub>	C <sub>1</sub>
IM20-1/8	17	30	6	43	99	166	62.5	132	20.5	42.5	60	11
	+ x C <sub>3</sub> + x C <sub>3</sub>											

Valve Islands	Dimension										
	C <sub>2</sub>	C <sub>3</sub>	D <sub>1</sub>	ØD <sub>2</sub>	ØD <sub>3</sub>	F	F <sub>1</sub>	H <sub>2</sub>	H <sub>3</sub>	H <sub>4</sub>	H <sub>5</sub>
IM20-1/8	26	23	G1/4	19x0.2	5.5	40	126	68	12	9	25

x C<sub>3</sub>= Dimension C<sub>3</sub> multiplied with number of valves

For order instructions see page 91, 135

Dimensions in mm

# Valve Islands with Multipole Connection Series IM20

G1/8

Multipole islands can be equipped with following valves.

- 5/2 Way Valves with springreturn
- 5/2 Way Impulse Valves
- 5/3 Way Valves with spring return to middle position
- middle position closed
- middle position exhausted
- middle position pressurized

**Versions:**

- Connection with sub-D connector
- Connection with heavy industrial connector
- With or without sensor inputs
- With multi-connection for sensor inputs (via 44pole sub-D connector)

**Accessories See page 92**

- Cable with sub-D plug
- Heavy industrial connector
- Straight plug M8 4pole

Connection with sub-D connector

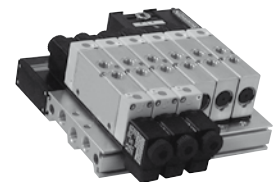

Connection with heavy industrial connector

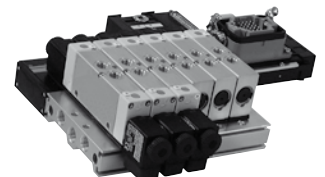

# Valve Islands with Multipole Connection Series IM20

G1/4

Multipole islands can be equipped with following valves:

- 5/2 Way Valves with spring return
- 5/2 Way Impulse Valves
- 5/3 Way Valves with spring return to middle position
  - middle position closed
  - middle position exhausted
  - middle position pressurized

### Versions:

- Connection with sub-D connector
- Connection with heavy duty industrial connector
- With or without sensor inputs
- With multi-connection for sensor inputs (via 44-pin sub-D connector)

### Accessories See page 92

- Cable with sub-D plug
- Heavy duty industrial connector
- Straight M8 4-pin connector

Connection with sub-D connector

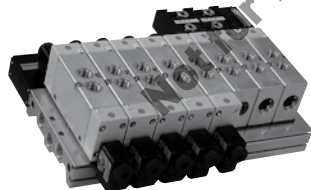

Connection with heavy duty industrial connector



Multipole Island with 25-pin sub-D connector (or heavy duty industrial connector) and 16 M8 4-pin feedback inputs with 44-pin sub-D connector

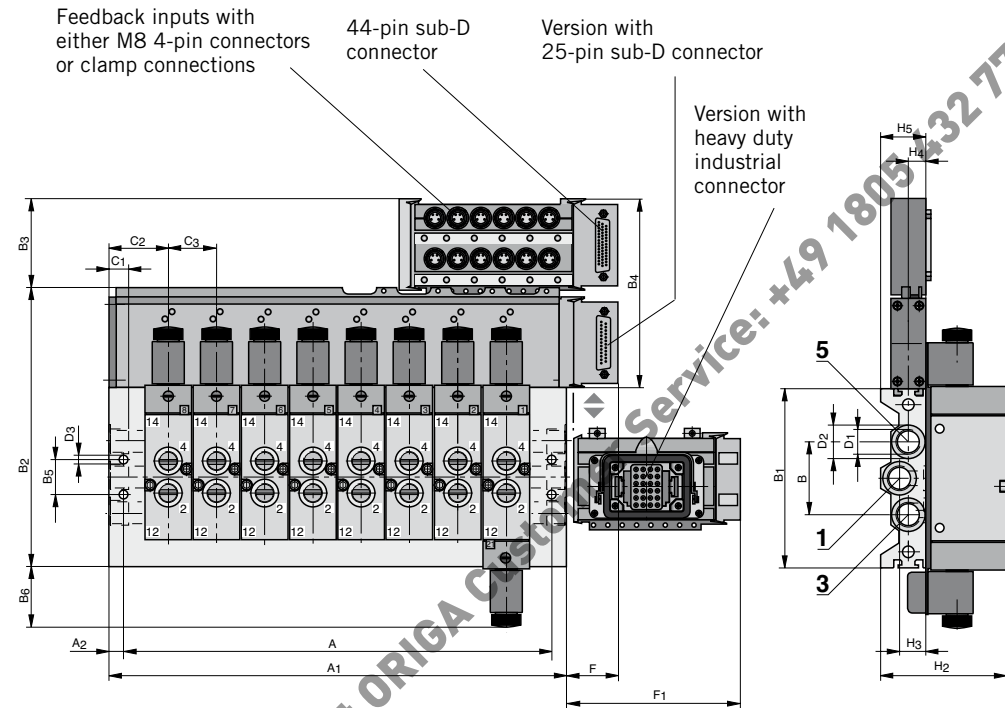

### Dimension Table (mm)

Valve Islands	Dimension											
	A	A <sub>1</sub>	A <sub>2</sub>	B	B <sub>1</sub>	B <sub>2</sub>	B <sub>3</sub>	B <sub>4</sub>	B <sub>5</sub>	B <sub>6</sub>	B <sub>7</sub>	C <sub>1</sub>
IM20-1/4	17	30	6	50	123	190	62.5	132	24	42.5	73.5	12
	+ x C <sub>3</sub>		+ x C <sub>3</sub>									

Valve Islands	Dimension										
	C <sub>2</sub>	C <sub>3</sub>	D <sub>1</sub>	ØD <sub>2</sub>	ØD <sub>3</sub>	F	F <sub>1</sub>	H <sub>2</sub>	H <sub>3</sub>	H <sub>4</sub>	H <sub>5</sub>
IM20-1/4	31	33	G3/8	23x0.5	6.2	40	126	86	18.5	12	31

x C<sub>3</sub>= Dimension C<sub>3</sub> multiplied by number of valves

For order instructions see page 91, 135

Dimensions in mm

**Order Instructions – Valve Islands**

**Example:**  
 Valve Islands with Multipole Connector, M8 assembled with:  
 1 item 5/2 Way Valves S9 581-1/8  
 7 item 5/2 Way Valves S9 581RF-1/8

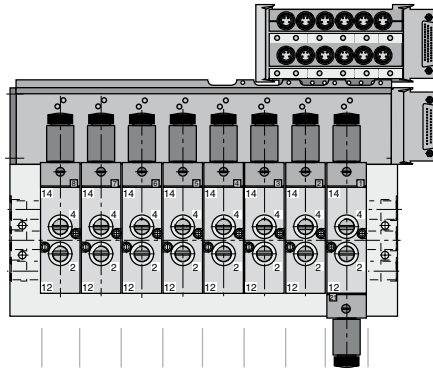

	Ident-No.										Electrical connection	Valves	Valve position												Input module	Number of inputs	Flow divider	Position of channel divider		
	1	2	3	4	5	6	7	8	9	10			11	12																
Example	P	A	1	0	3	8	1	D	S	0	8	M	M	M	M	M	M	J												

For order, please use the neutral order form on page 135

Valve Islands – Sizes	
PA	Type: IM20-1/8
10381	Connections: G1/8: valve outlets G1/4: base plate
PA12867	Type: IM20-1/4
	Connections: G1/4: valve outlets G3/8: base plate

Electrical Connection	
Multipol-Version	
DS	with sub-D-Connection
HI	with industrial connector

Valves	
04	to 4 valves
06	5 and 6 valves
08	7 and 8 valves
10	9 and 10 valves
12	11 and 12 valves
14	13 and 14 valves
16	15 and 16 valves

Important: Please specify the code for the desired valve types

Input Modules	
K	Pins IP20
S	M8 IP65 connector
04-08-12	Number of inputs
16-20-24	
28-32	

Dual Pressure Operating	
J	with channel divider in port 1
01 – 11	Position of channel divider to valve position

Ordering Code for Valves and Cover Plates		
Code	Symbol	Description
A	–	Cover plate on valve
M		5/3 Way Solenoid Valve, permanent signal with spring return Type: S9 581RF-..
J		5/3 Way Solenoid Valve, Impulse version Type: S9 581RF-..
G		5/3 Way Solenoid Valve, spring return to middle position, middle position closed Type: S9 581RFG-..
B		5/3 Way Solenoid Valve, spring return to middle position, middle position pressurized Type: S9 581RFB-..
E		5/3 Way Solenoid Valve, spring return to middle position, middle position exhausted Type: S9 581RFE-..

## Accessories for Valve Islands IM20

with Multipole Connector

- Cable with sub-D plug
- Heavy duty industrial connector
- Straight plug M8 4pole

### Cable with sub-D plug

Number of poles	Cable length	Order Instructions		Figure
		Type	Order No.	
25	1.0 m	GSK-25-1	KL9012	
25	3.0 m	GSK-25-3	KL9013	
25	5.0 m	GSK-25-5	KL9014	
44	5.0 m	GSK-44-5	KL9005	

### Heavy duty industrial connector with cable

Number of poles	Cable length	Order Instructions		Figure
		Type	Order No.	
24	5.0 m	K-IST-24	KL9003	

### Straight plug M8 for inputs

Number of poles	Use	Order Instructions		Figure
		Type	Order No.	
4	for own packing	K-M8-4	KL9011	

Not for new design - Please contact ORIGA Customer Service: +49 1805 432 717

## Contents

Version	Connection	Page	
		Dimension Table	Order Instructions
P-Manifolds	G1/8	92	92
	G1/4	93	93
	G1/2	94	94
RPS-Manifolds	G1/8	95	95
	G1/4	95	95

## P- and RPS- Supply Manifolds

*for directional valves*

*S9-G1/8*

*S9-G1/4*

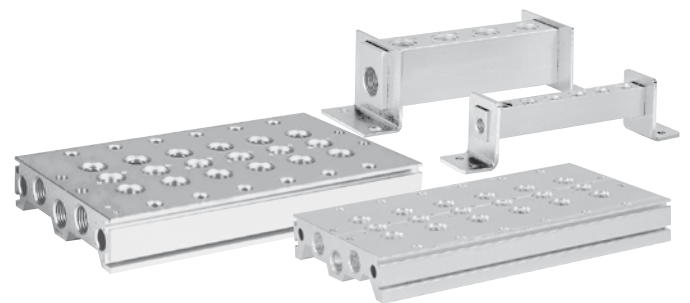

# P-Supply Manifold Series PLK, PL

for directional valves  
Series S9-G1/8

P-supply manifolds reduce and simplify tubing. They allow a clear, space-saving design.

3/2, 5/2 and 5/3 Way Valves with different types of actuation can be mounted in groups of 2-10.

Die Usage of Magnet-Impulse Valves is possible only with P-Manifold Type PL-...

**The delivery includes:**

- P-Manifold
- Mounting bracket
- Mounting Screws
- O-Rings

**Material**

Description	Material
P-Manifold	Al anodized
Mounting bracket	Steel passivated
Screws	Galvanized steel
O-Ring	NBR

P-Supply Manifold with short mounting brackets Type: PLK-1/8-..

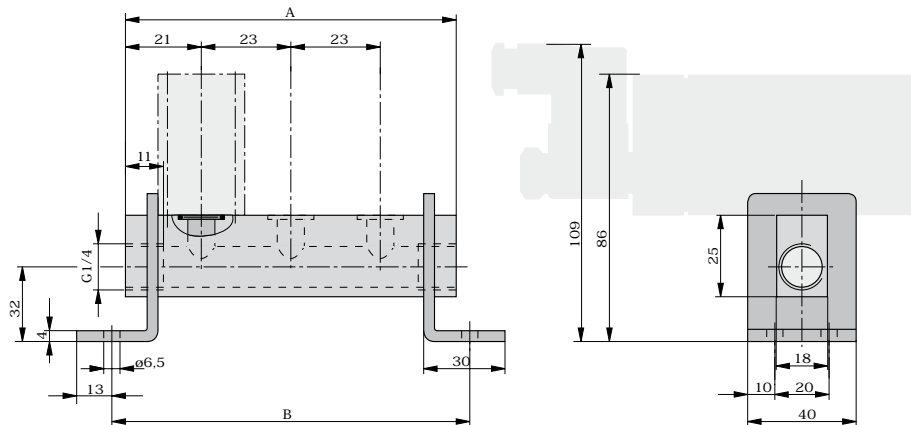

Drawing shows: PLK-1/8-3

P-Manifold with long mounting brackets Type: PL-1/8-..

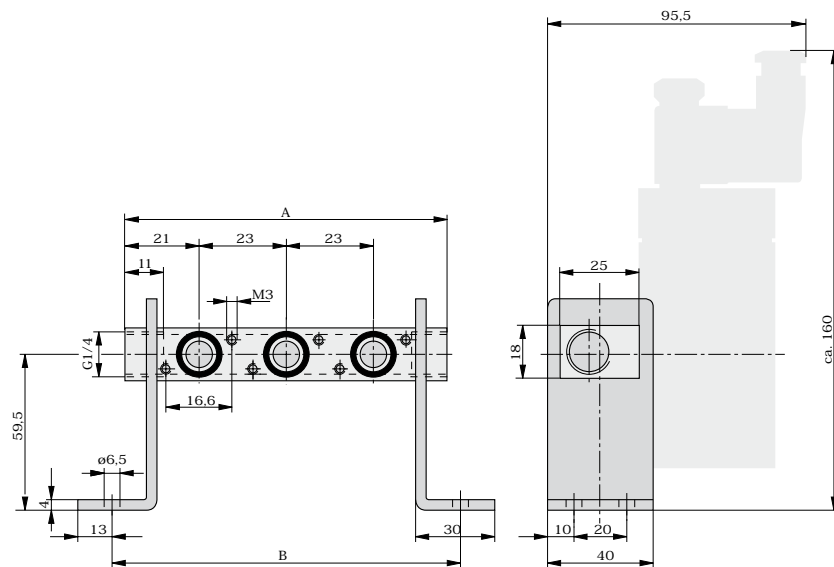

Drawing shows: PL-1/8-3



Overview for directional valves see page 70-77

Dimensions in mm



### Dimension Table (mm)

Type	Number of Valves	A	B
PLK-1/8-2	2	65	79
PL-1/8-2	2	65	79
PLK-1/8-3	3	88	102
PL-1/8-3	3	88	102
PLK-1/8-4	4	111	125
PL-1/8-4	4	111	125
PLK-1/8-5	5	134	148
PL-1/8-5	5	134	148
PLK-1/8-6	6	157	171
PL-1/8-6	6	157	171
PLK-1/8-7	7	180	194
PL-1/8-7	7	180	194
PLK-1/8-8	8	203	217
PL-1/8-8	8	203	217
PLK-1/8-9	9	226	240
PL-1/8-9	9	226	240
PLK-1/8-10	10	249	263
PL-1/8-10	10	249	263

### Order Instructions and Weight

Order In- Type	Order No.	Number of Valves	Consisting of				Weight (kg)
			Manifold	Bracket	Screws	O-Ring	
PLK-1/8-2	PD 37174-0002	2	1	2	4	2	0.28
PL-1/8-2	PD 32763-0002	2	1	2	4	2	0.28
PLK-1/8-3	PD 37174-0003	3	1	2	6	3	0.31
PL-1/8-3	PD 32763-0003	3	1	2	6	3	0.31
PLK-1/8-4	PD 37174-0004	4	1	2	8	4	0.34
PL-1/8-4	PD 32763-0004	4	1	2	8	4	0.34
PLK-1/8-5	PD 37174-0005	5	1	2	10	5	0.37
PL-1/8-5	PD 32763-0005	5	1	2	10	5	0.37
PLK-1/8-6	PD 37174-0006	6	1	2	12	6	0.40
PL-1/8-6	PD 32763-0006	6	1	2	12	6	0.40
PLK-1/8-7	PD 37174-0007	7	1	2	14	7	0.43
PL-1/8-7	PD 32763-0007	7	1	2	14	7	0.43
PLK-1/8-8	PD 37174-0008	8	1	2	16	8	0.47
PL-1/8-8	PD 32763-0008	8	1	2	16	8	0.47
PLK-1/8-9	PD 37174-0009	9	1	2	18	9	0.50
PL-1/8-9	PD 32763-0009	9	1	2	18	9	0.50
PLK-1/8-10	PD 37174-0010	10	1	2	20	10	0.53
PL-1/8-10	PD 32763-0010	10	1	2	20	10	0.53

### Accessories

Description	Order No.
Cover plate completely	PD 34694
Flow divider	PD 42483

# P-Supply Manifolds Series PLK, PL

for directional valves Series S9-G1/4

P-supply manifolds reduce and simplify tubing. They allow a clear, space-saving design. 3/2, 5/2 and 5/3 Way Valves with different types of actuation can be mounted in groups of 2-10 item. Die Usage of Magnet-Impulse Valves is possible only with P-Manifold Type PL-...

- The delivery includes:**  
 P-Manifold  
 Mounting bracket  
 Mounting Screws  
 O-Rings

Material	
Description	Material
P-Manifold	Al anodized
Mounting bracket	Steel passivated
Screws	Galvanized steel
O-Ring	NBR

P-Manifold with short mounting brackets Type: PLK-1/4-...

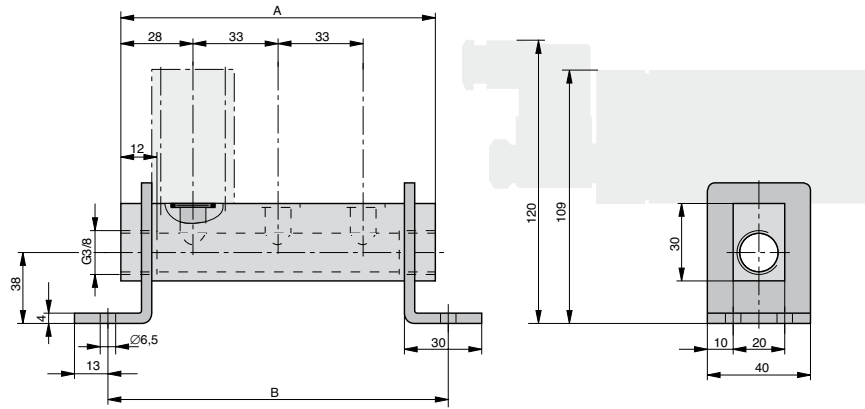

Drawing shows: PLK-1/4-3

P-Manifold with long mounting brackets Type: PL-1/4-..

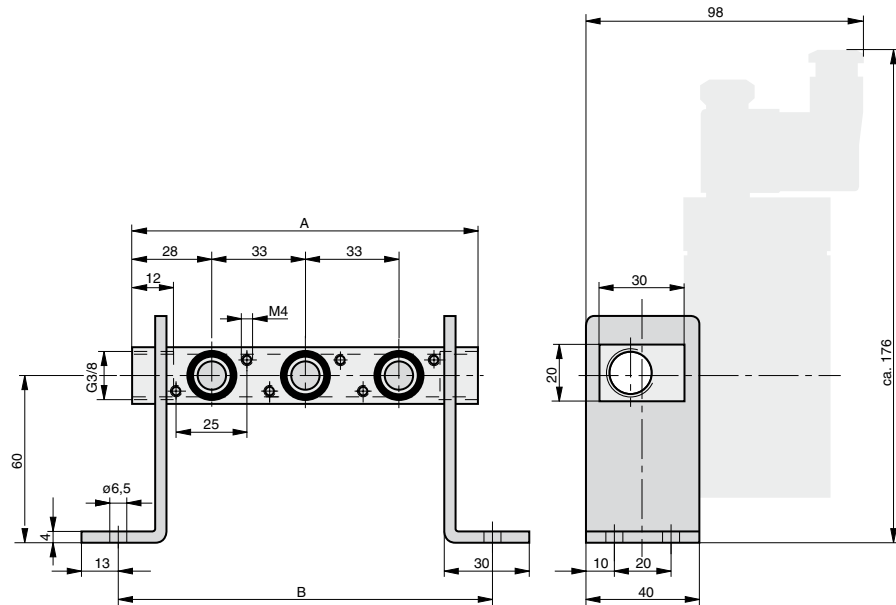

Drawing shows: PL-1/4-3



Overview for directional valves see page 70-77

Dimensions in mm

### Dimension Table (mm)

Type	Number of valves	A	B
PLK-1/4-2	2	89	99
PL-1/4-2	2	89	99
PLK-1/4-3	3	122	132
PL-1/4-3	3	122	132
PLK-1/4-4	4	155	165
PL-1/4-4	4	155	165
PLK-1/4-5	5	188	198
PL-1/4-5	5	188	198
PLK-1/4-6	6	221	231
PL-1/4-6	6	221	231
PLK-1/4-7	7	254	264
PL-1/4-7	7	254	264
PLK-1/4-8	8	287	297
PL-1/4-8	8	287	297
PLK-1/4-9	9	320	330
PL-1/4-9	9	320	330
PLK-1/4-10	10	353	363
PL-1/4-10	10	353	363

### Order Instructions and Weight

Order data		Number of valves	Consisting of				Weight (kg)
Type	Order No.		Manifold	Bracket	Ccrews	O-Ring	
PLK-1/4-2	PD 37175-0002	2	1	2	4	2	0.31
PL-1/4-2	PD 32765-0002	2	1	2	4	2	0.31
PLK-1/4-3	PD 37175-0003	3	1	2	6	3	0.35
PL-1/4-3	PD 32765-0003	3	1	2	6	3	0.35
PLK-1/4-4	PD 37175-0004	4	1	2	8	4	0.39
PL-1/4-4	PD 32765-0004	4	1	2	8	4	0.39
PLK-1/4-5	PD 37175-0005	5	1	2	10	5	0.43
PL-1/4-5	PD 32765-0005	5	1	2	10	5	0.43
PLK-1/4-6	PD 37175-0006	6	1	2	12	6	0.47
PL-1/4-6	PD 32765-0006	6	1	2	12	6	0.47
PLK-1/4-7	PD 37174-0007	7	1	2	14	7	0.51
PL-1/4-7	PD 32765-0007	7	1	2	14	7	0.51
PLK-1/4-8	PD 37175-0008	8	1	2	16	8	0.55
PL-1/4-8	PD 32765-0008	8	1	2	16	8	0.55
PLK-1/8-9	PD 37175-0009	9	1	2	18	9	0.59
PL-1/4-9	PD 32765-0009	9	1	2	18	9	0.59
PLK-1/4-10	PD 37175-0010	10	1	2	20	10	0.63
PL-1/4-10	PD 32765-0010	10	1	2	20	10	0.63

### Accessories

Description	Order No.
Cover plate completely	PD 34695
Flow divider	PD 42516

# P-Manifolds Series PL

for way valves  
Series S9-G1/2

P-supply manifolds reduce and simplify tubing. They allow a clear, space-saving design.  
3/2, 5/2 and 5/3 Way Valves with different types of actuation can be mounted in groups of 2-4 item.

### The delivery includes:

- P-Manifold
- Mounting bracket
- Mounting Screws
- O-Rings

### P-Manifold with short mounting brackets – Type: PL-1/2-..

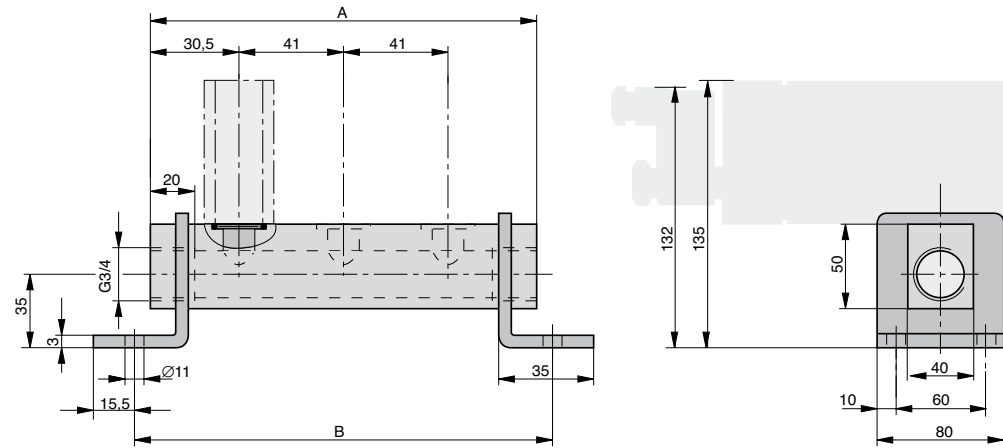

Drawing shows: PL-1/2-3

### Material

Description	Material
P-Manifold	Al anodized
Mounting bracket	Steel chromanized
Screws	Galvanized steel
O-Ring	NBR

### Dimension Table (mm)

Type	Number of valves	A	B
PL-1/2-2	2	102	122
PL-1/2-3	3	143	163
PL-1/2-4	4	184	204

### Accessories

Description	Order No.
Cover plate completely	PD 39138

### Order Instructions and Weight

Order data		Number of valves	consisting of				Weight (kg)
Type	Order No.		Manifold	Mounting bracket	Screws	O-Ring	
PL-1/2-2	PD 39016-0002	2	1	2	4	2	0.45
PL-1/2-3	PD 39016-0003	3	1	2	6	3	0.60
PL-1/2-4	PD 39016-0004	4	1	2	8	4	0.80



Overview for directional valves see page 70-77

Dimensions in mm

**RPS-manifold – Type: RPSL-S9-1/8-**

Dimension A and B see Tabelle

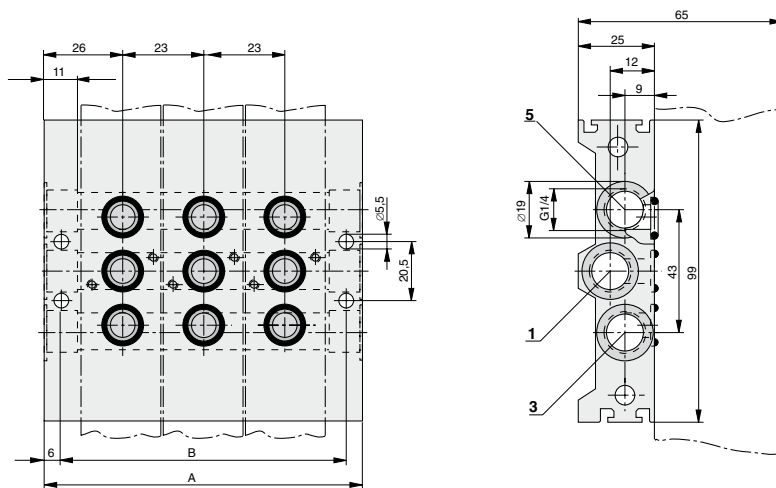

Drawing shows: RPSL-S9-1/8-3

**Dimension Table (mm)**

Type	Number of valves	A	B
RPSL-S9-1/8-2	2	75	63
RPSL-S9-1/8-3	3	98	86
RPSL-S9-1/8-4	4	121	109
RPSL-S9-1/8-5	5	144	132
RPSL-S9-1/8-6	6	167	155
RPSL-S9-1/8-7	7	190	178
RPSL-S9-1/8-8	8	213	201
RPSL-S9-1/8-9	9	236	224
RPSL-S9-1/8-10	10	259	247

**Order Instructions and Weight**

Order data		Number of valves	consisting of			Weight (kg)
Type	Order No.		Manifold	Screws	O-Ring	
RPSL-S9-1/8-2	PD 44813-0002	2	1	4	6	0.470
RPSL-S9-1/8-3	PD 44813-0003	3	1	6	9	0.570
RPSL-S9-1/8-4	PD 44813-0004	4	1	8	12	0.670
RPSL-S9-1/8-5	PD 44813-0005	5	1	10	15	0.770
RPSL-S9-1/8-6	PD 44813-0006	6	1	12	18	0.870
RPSL-S9-1/8-7	PD 44813-0007	7	1	14	21	0.970
RPSL-S9-1/8-8	PD 44813-0008	8	1	16	24	1.070
RPSL-S9-1/8-9	PD 44813-0009	9	1	18	27	1.170
RPSL-S9-1/8-10	PD 44813-0010	10	1	20	30	1.270

# RPS-Manifolds Series RPSL

for directional valves Series S9-G1/8

RPS-supply manifolds reduce and simplify tubing. They allow a clear, space-saving design.

The RPS manifolds have a common compressed air supply (P) and common vent lines (R,S).

Valves can be mounted in groups of 2-10.

– RPS-Manifolds for more valves on request

**The delivery includes:**

- RPS-supply manifold
- Mounting Screws
- O-Rings

**Material**

Description	Material
P-Manifold	Al anodized
Screws	Galvanized steel
O-Ring	NBR

**Accessories**

Description	Order No.
Cover strip completely G1/8	PD 32956
Flow divider G1/8	PD 42483

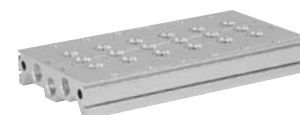

# RPS-Manifolds Series RPSL

for directional valves  
Series S9-G1/4

RPS-Supply manifolds reduce and simplify tubing. They allow a clear, space-saving design.  
The RPS manifolds have a common compressed air supply (P) and common vent lines (R,S).

Valves can be mounted in groups of 2-10.  
– RPS-Manifolds for more valves on request

**The delivery includes:**  
RPS-supply manifold  
Mounting screws  
O-Rings

## Material

Description	Material
P-Manifold	Al anodized
Screws	Galvanized steel
O-Ring	NBR

## Accessories

Description	Order No.
Cover strip completely G1/4	PD 32957
Flow divider G1/4	PD 42483

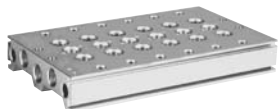

RPS-Supply Manifold – Type: RPSL-S9-1/4-..

Dimension A and B see Tabelle

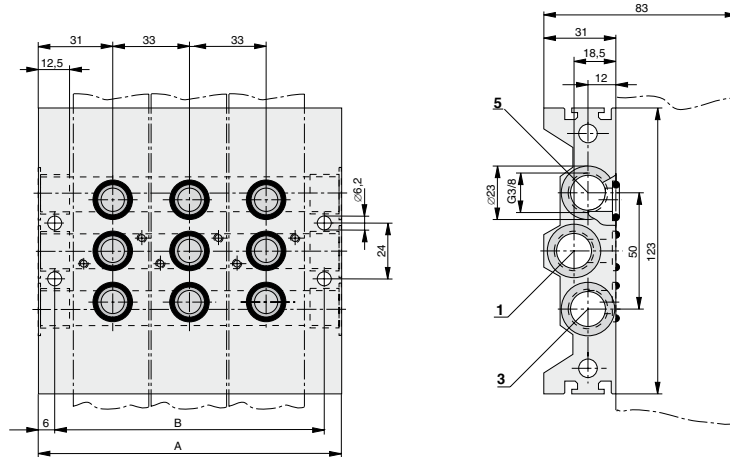

Drawing shows: RPSL-S9-1/4-3

## Dimension Table (mm)

Type	Number of valves	A	B
RPSL-S9-1/4-2	2	95	83
RPSL-S9-1/4-3	3	128	116
RPSL-S9-1/4-4	4	161	149
RPSL-S9-1/4-5	5	194	182
RPSL-S9-1/4-6	6	227	215
RPSL-S9-1/4-7	7	260	248
RPSL-S9-1/4-8	8	293	281
RPSL-S9-1/4-9	9	326	314
RPSL-S9-1/4-10	10	359	347

## Order Instructions and Weight

Order data		Number of valves	consisting of			Weight (kg)
Type	Order No.		Manifold	Screws	O-Ring	
RPSL-S9-1/4-2	PD 44814-0002	2	1	4	6	0.845
RPSL-S9-1/4-3	PD 44814-0003	3	1	6	9	1.045
RPSL-S9-1/4-4	PD 44814-0004	4	1	8	12	1.245
RPSL-S9-1/4-5	PD 44814-0005	5	1	10	15	1.445
RPSL-S9-1/4-6	PD 44814-0006	6	1	12	18	1.645
RPSL-S9-1/4-7	PD 44814-0007	7	1	14	21	1.845
RPSL-S9-1/4-8	PD 44814-0008	8	1	16	24	2.045
RPSL-S9-1/4-9	PD 44814-0009	9	1	18	27	2.245
RPSL-S9-1/4-10	PD 44814-0010	10	1	20	30	2.445

Overview for directional valves see page 70-77

Dimensions in mm

## Special Valves

*Connection size  
G1/8 to G2*

### Contents

Version	Actuation	Port size	Page		
			Characteristics	Dimensions	Order Instructions Overview
3/2, 5/2 and 5/3 Way Valves with NAMUR-connections Series S9	Electrical	G1/8 G1/4	102, 103	104-106	107
5/2 Way Valves for Two Hand Operation Series S9	Hand	G1/8 G1/4	108, 109	109	110
Time Delay Valve for 2-Hand Safety Start Valve	Pneumatic (Timer)	G1/8	108, 109	110	110
5/2 Way Oscillating Valves, Series S9	Pneumatic	G1/4	111	111	112
3/2 and 5/2 Way-Pedal actuated valve, Series F	Pedal	G1/4	113	113	114
2/2 Way Stop Valve Series ARKV	Pneumatic	G1/2 G3/4 G1 G1 1/2 G2	115	116	116



# Way Valves with NAMUR Connections

*Characteristics  
for Standard Valves*

## Series S9 – G1/8, G1/4 NAMUR

Characteristics	Symbol	Unit	Series S9	
			G1/8	G1/4
Actuation			Electrically actuated	Electrically actuated
General Features				
Type			Spoolvalve	Spoolvalve
Mounting			2 Screws M5	2 Screws M6
Tube connection			Thread/NAMUR connections	Thread/NAMUR connections
Thread			G1/8 – 7,4 deep	G1/4 – 11 deep
Weight		kg	0.245 permanent signal version	0.600 permanent signal version
		kg	0.340 impulse version	0.700 impulse version
Installation			In any position	In any position
Ambient temperature range <sup>(1)</sup>	T <sub>min. / max.</sub>	°C	-10 to +60	-10 to +60
Medium temperature range <sup>(1)</sup>	T <sub>min. / max.</sub>	°C	-10 to +60	-10 to +60
Medium			Filtered compressed air	
Lubrication			With or without oil mist lubrication (We recommend the use of mineral oil type VG 32 to ISO 3448)	
Pneumatic Characteristics				
Nominal pressure	p <sub>min. / max.</sub>	bar	6	
Operating pressure range				
– permanent signal version	p <sub>min. / max.</sub>	bar	2–10	
– impulse version	p <sub>min. / max.</sub>	bar	1.5–10	
Nominal flow	Q <sub>N</sub>	l/min	500	1300 <sup>(3)</sup>
Actuation				
Electrical			Pilot operated	
Voltage type			Alternating current (50/60Hz)	Direct current
Nominal voltage				
– Standard version	Un	V	230 ±10%	24 ±10% other voltages on request
– Low wattage version	Un	V	230 ±10%	24 ±10% other voltages on request
Initial power consumption				
– Standard version		VA (W)	8.5	2.5
– Low wattage version		VA (W)	6.6	2.1
Continuous consumption				
– Standard version		VA (W)	6.0	2.5
– Low wattage version		VA (W)	3.9	2.1
Duty cycle	ED	%	100	
Electrical protection		IP	IP 65 to DIN 40050 (applies only to solenoid with connector)	
Connection			Plug to DIN EN 175301-803 form B – industrial standard <sup>(2)</sup>	

<sup>(1)</sup> Note :  
Please consult us for operating temperatures below 0° C

<sup>(2)</sup> Low wattage version connector DIN EN 175301-803 form A

<sup>(3)</sup> Version “middle position vented“ 1000 l/min





### Series S9 – G1/8, G1/4 NAMUR

Characteristics	Symbol	Unit	Series S9 G1/8	G1/4
Actuation			Electrically actuated	Electrically actuated
General Features				
Type			Spool valve	Spool valve
Mounting			2 Screws M5	2 Screws M6
Tube connection			Thread/NAMUR connections	Thread/NAMUR connections
Weight		kg	0.245 permanent signal version	0.600 permanent signal version
			0.340 impulse version	0.700 impulse version
Installation			In any position	In any position
Ambient temperature range <sup>(1)</sup>	T <sub>min. / max.</sub>	°C	-10 to +60	-10 to +60
Medium temperature range <sup>(1)</sup>	T <sub>min. / max.</sub>	°C	-10 to +60	-10 to +60
Medium			Filtered, unlubricated compressed air – free from water and dirt to ISO 8573-1 Solids: Class 7 particle < 40µm for gas Water content: pressure dew point +3°C, Class 4, but at least 5 °C below minimum operating temperature	
Pneumatic Characteristics				
Nominal pressure	p <sub>min. / max.</sub>	bar	6	
Operating pressure range				
– permanent signal version	p <sub>min. / max.</sub>	bar	2–8	
– impulse version	p <sub>min. / max.</sub>	bar	1.5–8	
Nominal flow	Q <sub>N</sub>	l/min	500	1300 <sup>(3)</sup>
Actuation				
Electrical			Pilot operated	
Certification			EC Type Test Certificate for single valve: not required for mechanical units EC Type Test Certificate for solenoid coil: PTB-No. 03 Ex IEC 2019X and PTB 03 ATEX 2018X to T5	
Category, type of ignition protection			Single valve: Ⓢ II 2G c T4 T135°C -10°C≤Ta≤+60°C Solenoid/individual use: Ⓢ II 2G EEx m II T5 -20°C≤Ta≤+50°C Solenoid/manifold mounting: Ⓢ II 2G EEx m II T5 -20°C≤Ta≤+40°C	
Voltage type			Alternating current (50/60Hz)	Direct current
Nominal voltage	UN	V	230 ±10% 110 ±10% 24 ±10%	24 ±10% other voltages on request
Max. switching frequency		Hz	1	
Connection			G1/8, G1/4	G1/8, G1/4
Power rating at U <sub>N</sub>		VA (W)	3.1 (230V) 3.0 (110V) 2.5 (24V)	3.3 (24V)
Max. power at U <sub>N</sub> <sup>(2)</sup>		VA (W)	2.9 (230V) 2.8 (110V) 2.4 (24V)	3.0 (24V)
Electrical protection		IP	IP65 (applies only to solenoid with cable)	
Connection			Cable – cable lengths see Order Instructions	

## Way Valves with NAMUR Connections

*Characteristics for Valves in EX Areas*

<sup>(1)</sup> Note : Please consult us for operating temperatures below 0° C

<sup>(2)</sup> Maximum power if warmed up to thermal load limit

<sup>(3)</sup> Version “middle position vented“ 1000 l/min



# 3/2 Way Valves Series S9

Electrically actuated – Type: S9 381RF-1/4-NC S0

G1/4

**Actuation systems:**  
– Electrical pilot operated

**Versions:**  
– With NAMUR connections  
– Version to ATEX Standard

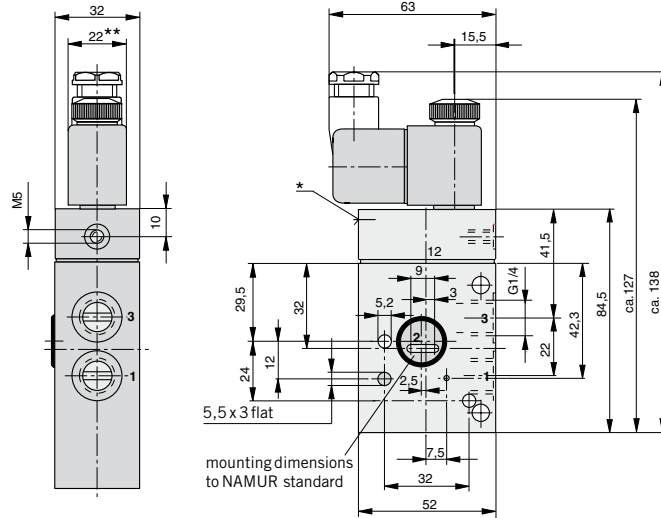

- \* Manual override
- \*\* Solenoid width = 30 mm on low wattage coil version

## Solenoid for use in EX areas Dimensions

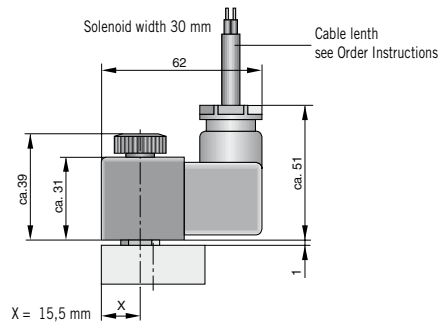

### The delivery includes:

- 1 Valve
- 2 Mounting Screws
- 1 Coding pin
- 2 O-Rings

For more information on valves to ATEX standards  
see page 46, 47, 107



Overview see page 107

Dimensions in mm

Electrically actuated – Type: S9 581...-1/8 SO

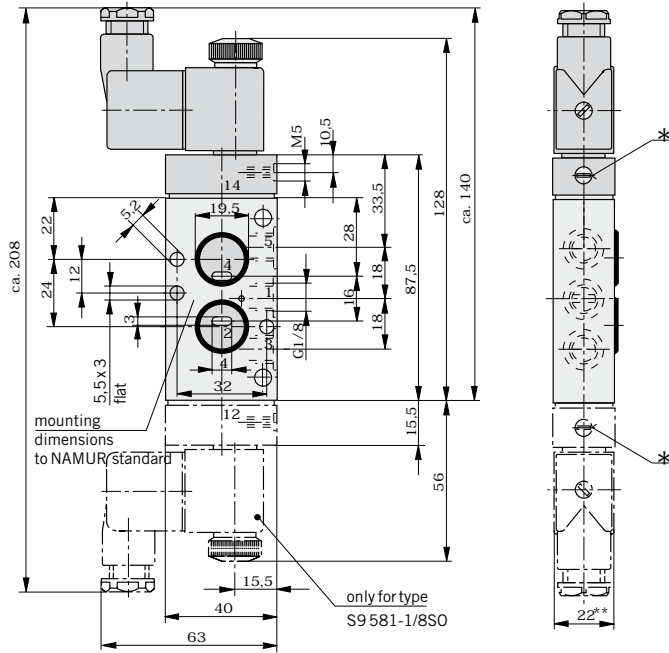

- \* Manual override
- \*\* Solenoid width = 30 mm on low wattage coil version

# 5/2 Way Valves Series S9

G1/8, G1/4

Actuation systems:  
– Electrical pilot operated

Versions:  
– With NAMUR connections  
– Version to ATEX standard

Electrically actuated – Type: S9 581...-1/4 SO

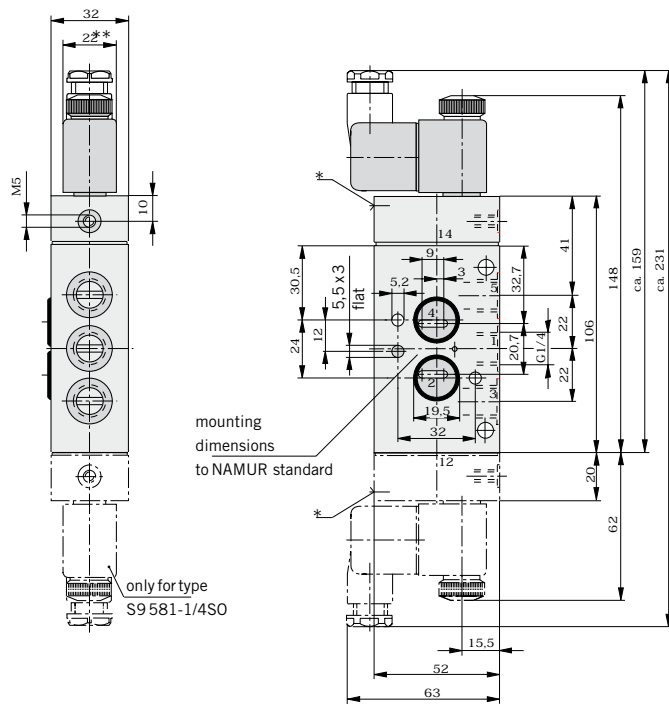

Solenoid for use in EX areas  
Dimensions

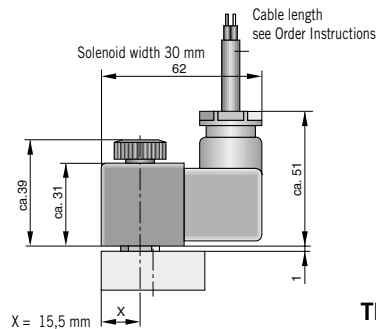

For more information on valves to ATEX standards see page 46, 47, 107

- The delivery includes:
- 1 Valve
  - 2 Mounting Screws
  - 1 Coding pin
  - 2 O-Rings

- \* Manual override
- \*\* Solenoid width = 30 mm on low wattage coil version

Overview see page 107

Dimensions in mm



# 5/3 Way Valves Series S9

G1/8, G1/4

Actuation systems:  
- Electrical pilot operated

Versions:  
- With NAMUR connections  
- Version to ATEX Standard

Electrically actuated – Type: S9 581RF.-1/8-NC SO

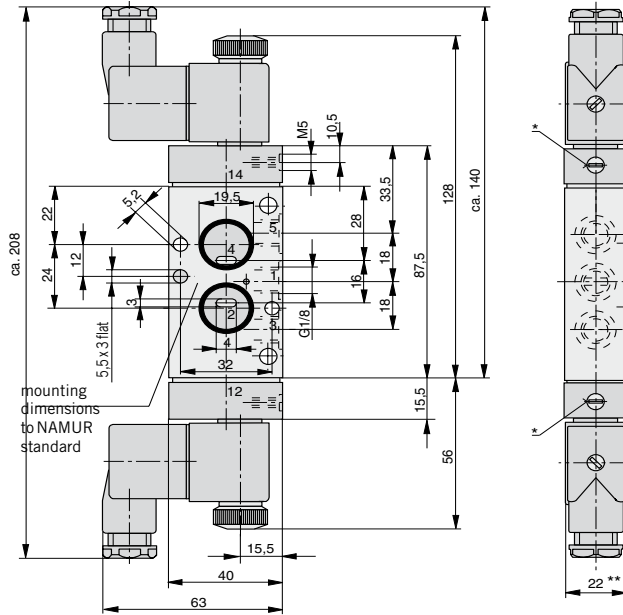

\* Manual override  
\*\* Solenoid width = 30 mm on low wattage coil version

Electrically actuated – Type: S9 581RF.-1/4-NC SO

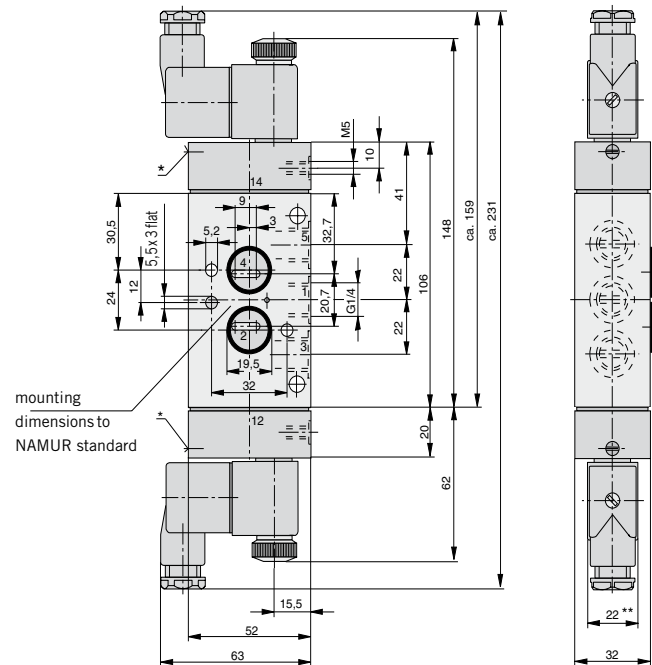

Solenoid for use in EX areas  
Dimensions

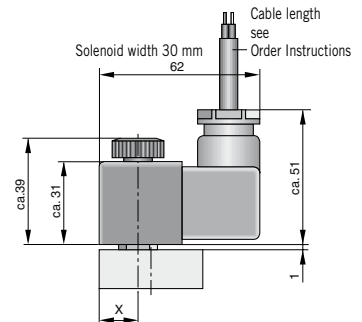

For more information on valves to ATEX standards see page 46, 47, 107

\* Manual override  
\*\* Solenoid width = 30 mm on low wattage coil version



Overview see page 107

Dimensions in mm

### Order Instructions – 3/2, 5/2 and 5/3 Way Valves – with NAMUR connections

Actuation System	Symbol	Order Instructions		Page
		Type	Order No.	
Electrical, permanent signal		S9 381RF-1/4NG SO-..	PD 33854-..33	104
Electrical, permanent signal		S9 581RF-1/8 SO-..	PD 34143-..33	105
		S9 581RF-1/4 SO-..	PD 34985-..33	105
Electrical, impulse		S9 581-1/8 SO-..	PD 34984-..33	105
		S9 581-1/4 SO-..	PD 34986-..33	105
Electrical, permanent signal spring return to middle position		S9 581RFG-1/8 SO-..	PD 40813-..33	106
		S9 581RFG-1/4 SO-..	PD 40808-..33	106
		S9 581RFE-1/8 SO-..	PD 40814-..33	106
		S9 581RFE-1/4 SO-..	PD 40618-..33	106
		S9 581RFB-1/8 SO-..	PD 40815-..33	106
		S9 581RFB-1/4 SO-..	PD 40809-..33	106

Solenoid version	Nominal voltage	Applicable for	Key code	ATEX Type additon
Standard version	230V 50/60Hz	110 V =	61	-
	24V =	60V 50/60Hz	02	-
Low wattage version	24V =		13	-
	230V 50/60Hz		69	-

#### EX Area versions to ATEX Standard

##### Category, type of ignition protection

Single valve: Ⓜ II 2G c T4 T135°C -10°C≤Ta≤+60°C

Solenoid/individual use: Ⓜ II 2G EEx m II T5 -20°C≤Ta≤+50°C

Solenoid/manifold mounting: Ⓜ II 2G EEx m II T5 -20°C≤Ta≤+40°C

Solenoid version	Nominal voltage	Applicable for	Key code	ATEX Type additon
Solenoid	24V =		48	ATEX
- with cable 1.2 m				
- with cable 3 m	24V =		45	ATEX
- with cable 5 m	24V =		46	ATEX
- with cable 10 m	24V =		47	ATEX
- with cable 1.2 m	24V 50/60Hz		99	ATEX
- with cable 1.2 m	110V 50/60Hz		97	ATEX
- with cable 1.2 m	230V 50/60Hz		98	ATEX

#### Example for valves in ATEX-Version:

- for valves Series S9-G1/8, S9-G1/4, S9-G1/2

Please add behind the standard order No. "ATEX"

**Type: S9 581RFG-1/8SO-4633**

**Order No. PA34143-4633ATEX**

# 5/2 Way Valve Series S9

G1/8, G1/4

## Actuation System: – Pneumatic for two hand operation

2 hand operated valve for pneumatically controlled machines and equipment.

The 2-handed trip valves PD37173 and PD37673 are classed as category 1 in accordance with DIN EN 954-1 (only in connection with suitable push button valves) and type IIIA in accordance with DIN EN 574.

**ISO 13851:**  
Safety of machines; two-handed controls.

**ISO 13849-1:**  
Safety of machines; safety-related parts of control systems.

**Area of application:**  
The 2-handed safety valves are intended to be used where persons carry out manual control functions in areas that are subject to accident risks. These comprise primarily equipment with pneumatic cylinders, the operation of which requires that both hands are kept away from the danger zone. The valves can also be used to prevent unintended starts of pneumatic processes.



## Characteristics – Pneumatically actuated with 2 hand operation and Time Delay Valve

Characteristics	Symbol	Unit	Description		
Version			Two Hand Operation		Time Delay Valve
Type			S9 563/65RF-1/8-SO	S9 563/65RF-1/4-SO	S9 361RF-1/8-SO
General Features					
Type			Spool valve	Spool valve	Spool valve
Mounting			2 Screws M5	2 Screws M6	2 Screws M5
Tube connection			Thread	Thread	Thread
Port size			G1/8	G1/4 (12.1 and 12.2: G1/8)	G1/8
Weight (mass)		kg	0.27	0.64	0.18
Installation			In any position		
Ambient temperature range	T <sub>min/max</sub>	°C	-10 to +60 **		
Medium temperature range	T <sub>min/max</sub>	°C	-10 to +60 **		
Medium			Filtered compressed air - free from water and dirt to ISO 8573-1 Solids: Class 6 particle <5µm for Gas gaswater content: pressure dew point +3°C, Class 4, but at least 5°C less than min. operating temperature		
Lubrication *			none or oil mist lubrication		
Pneumatic Characteristics					
Nominal pressure	p <sub>n</sub>	bar	6		
Operating pressure range	p <sub>min/max</sub>	bar	0 – 10		2-10
Nominal flow	Q <sub>N</sub>	l/min	500	1300	450
Actuation					
Pneumatic			Direct		
Actuation pressure range	p <sub>st min/max</sub>		2 – 10	3 – 10	2-10

\* We recommend the use of mineral oil type VG 32 to ISO 3448

\*\* Note: Please consult us for operating temperatures below 0° C

### Function:

The valve only switches from outlet port 4 to outlet port 2 if both signal inlets are simultaneously actuated or are actuated within 0.5 s. When the operator releases one or both control buttons, the valve switches back immediately.

In order to resume the switch function, both trip signals have to be cancelled first.

### Note:

Not applicable for operating eccentric presses and presses of similar design.

### Fitting Instructions:

If due to mechanical stopping and re-opening of the compressed air supply both control buttons are operated or possibly blocked at the same time, the 2-handed trip valve will continue the control function. The 2-handed trip valve is not suited to prevent the switching from port 4 to port 2 upon the compressed air being switched back on after it was shut off and/or permanently operated control buttons.

In order to prevent this process from happening, we advise users that it is necessary to install a time-delay valve in the supply line of one of the control buttons (line 12.1 or 12.2).

**We recommend the following time-delay valve from our range: type PD49078.**

**As push button valve we recommend the basic valve PA10307 for control panel configuration, in combination with push button KX9357.**

Characteristics of time-delay valve see table above.

Dimensions in mm

**Safety switch diagram (example)**  
**Usage of 2-hand-operation valve with necessary time delay valve**

In order to comply with safety requirements, plant and equipment with certain operating mechanisms require the installation of a time-delay valve in the pneumatic control system, as shown in the example.

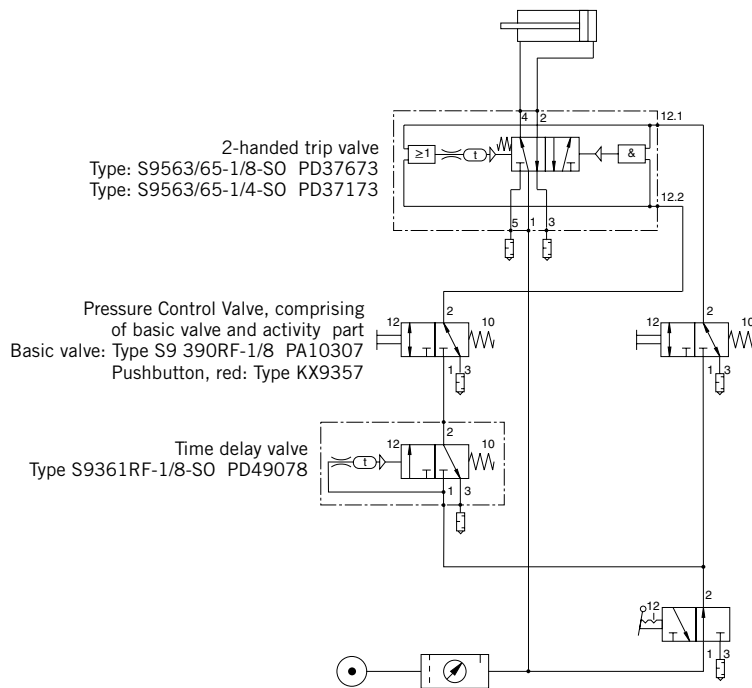

**Pneumatically actuated by 2-handed trip valve**  
**Type: S9 563/65RF-1/8-SO**

**Type: S9 563/65RF-1/4-SO**

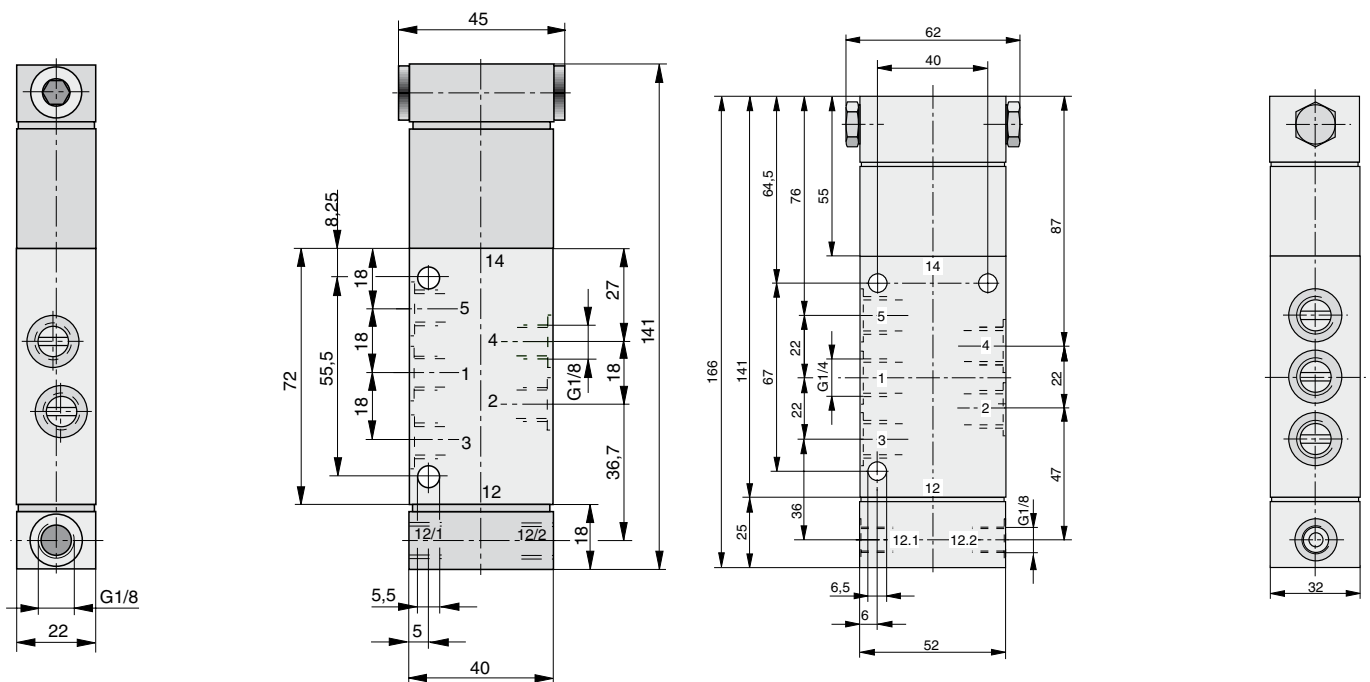

Dimensions in mm

**Time-delay valve to 2-handed trip valve**  
**Type: S9 361RF-1/8-SO**

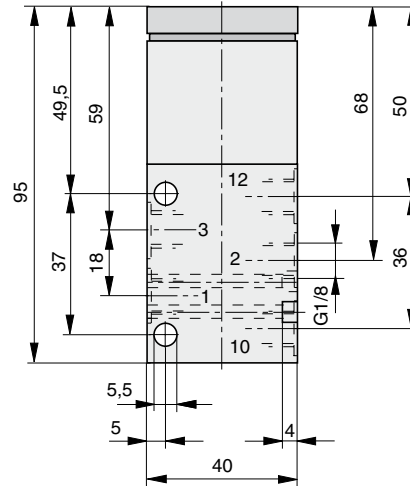
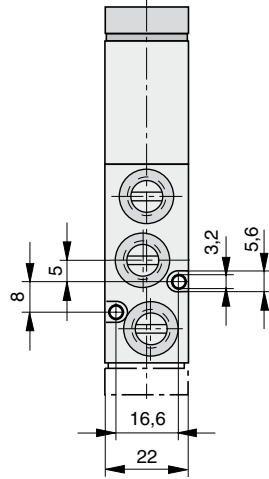

**Note:**  
 Suitable measures must be taken to protect the valves against ingress of dust and water.

**Order Instructions**

Actuation System	Symbol	Order Instructions	
		Type	Order No.
pneumatic, by 2-hand tripping		S9 563/65RF-1/8-SO	PD37673
		S9 563/65RF-1/4-SO	PD37173
Time Delay Valve for 2-Hand-safety related control		S9 361RF-1/8-SO	PD49078



### Characteristics

Characteristics	Symbol	Unit	Description
General Features			
Type			Spool valve
Mounting			2 Screws M6 (M4)
Tube connection			Thread
Connection size			G1/4, 11 deep
Weight (mass)		kg	0.65
Installation			In any position
Ambient temperature range **	$T_{min/max}$	°C	-10 to +60
Medium temperature range **	$T_{min/max}$	°C	-10 to +60
Medium			Filtered and oiled or filtered, unoled compressed air
Lubrication *			None or oil mist lubrication
Pneumatic Characteristics			
Nominal pressure	$p_n$	bar	6
Operating pressure range	$p_{min/max}$	bar	3–8
Nominal flow	$Q_N$	l/min	1300
Actuation			
Pneumatic			Direct
Actuation pressure range	$p_{st min/max}$		3–8

\* We recommend the use of mineral oil type VG 32 to ISO 3448

\*\* Note: Please consult us for operating temperatures below 0°C

## 5/2-Way Oscillating Valves Series S9

G1/4

**Actuation System:**  
–Pneumatic

The oscillating valve generates oscillating movements such as e.g. shaking, hammering, plunging, feed motions etc.

**Function:**  
If compressed air is introduced into inlet port 1, the outlet ports 4 and 2 are alternately supplied with compressed air. The speed of the operated cylinder and also the stroke frequency are adjusted with two exhaust air throttles.

### Pneumatic oscillating – Type: S9 568/68-1/4-S0

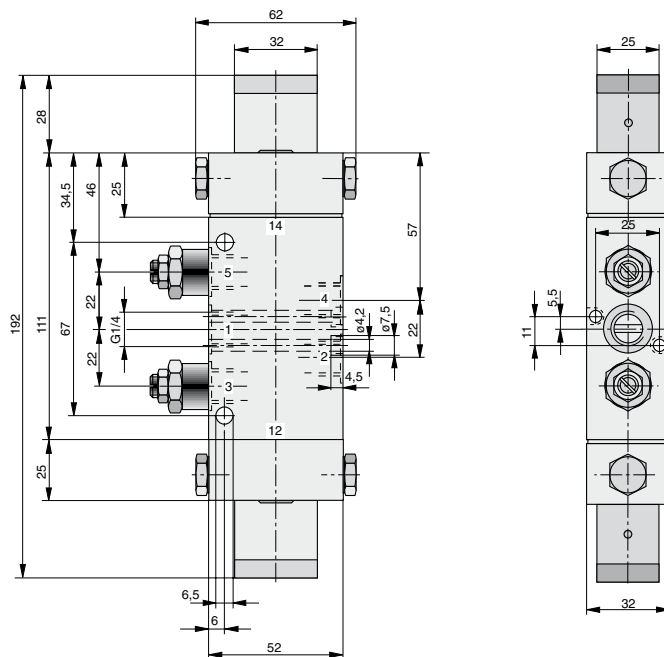

Dimensions in mm

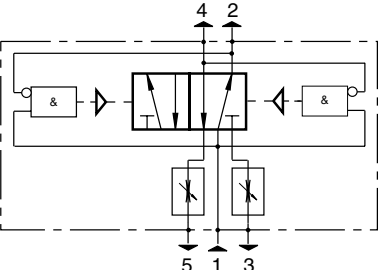

**Order Instructions**

Actuation System	Symbol	Order Instructions	
Pneumatic	 <p>The diagram shows a 5/2-way valve symbol. It consists of a central rectangular box with two vertical lines representing the valve's internal mechanism. Above the box are two ports labeled '4' and '2'. Below the box are two ports labeled '5' and '3'. Two solenoid actuators, represented by rectangles with an ampersand (&amp;) and a triangle, are connected to the valve. Two check valves, represented by rectangles with a diagonal line, are also connected to the valve. The entire symbol is enclosed in a dashed rectangular border.</p>	Type S9 568/68-1/4-S0	Order No. PD 34796

Dimensions in mm

## Characteristics

Characteristics	Symbol	Unit	Description
General Features			
Type			Poppet Valve
Mounting			4 Screws M8 <sup>(1)</sup>
Tube connection			Thread
Port size			G1/4
Weight (mass)		kg	1.5
Installation			In any position
Ambient temperature range <sup>(3)</sup>	T <sub>min/max</sub>	°C	-10 to +55
Medium temperature range <sup>(3)</sup>	T <sub>min/max</sub>	°C	-10 to +60
Medium			Filtered and oiled or filtered, unoled compressed air
Lubrication <sup>(2)</sup>			Oil mist lubrication compatible with Buna N
Pneumatic Characteristics			
Nominal pressure	p <sub>n</sub>	bar	6
Operating pressure range	p <sub>min/max</sub>	bar	0 – 10
Nominal flow	Q <sub>N</sub>	l/min	1400
Actuation			
Manual control			Direct
Stroke		mm	2
Actuation force	F <sub>b</sub>	N	ca. 30

<sup>(1)</sup> After removing the rubber footing

<sup>(2)</sup> We recommend the use of mineral oil type VG 32 to ISO 3448

<sup>(3)</sup> Note: Please consult us for operating temperatures below 0° C

## 3/2 and 5/2 Way Valves Pedal actuated Series F

G1/4

Actuation System:  
- Pedal

Connections for 3/2 way version:

Version

„Normally closed“: P, B, S

„Normally open“: P, A, R

\* Only for version “both switch positions indexed” – return is only effected after actuating the locking pedal.

**Mounting Instruction:**

Use only screw connections with max. wrench size across flats of 15.

**Connection designation:**

A = 4 Outlet

B = 2 Outlet

R = 5 Exhaust

P = 1 Air supply

S = 3 Exhaust

### Pedal actuated – Type: F331...-08..., F531...-08

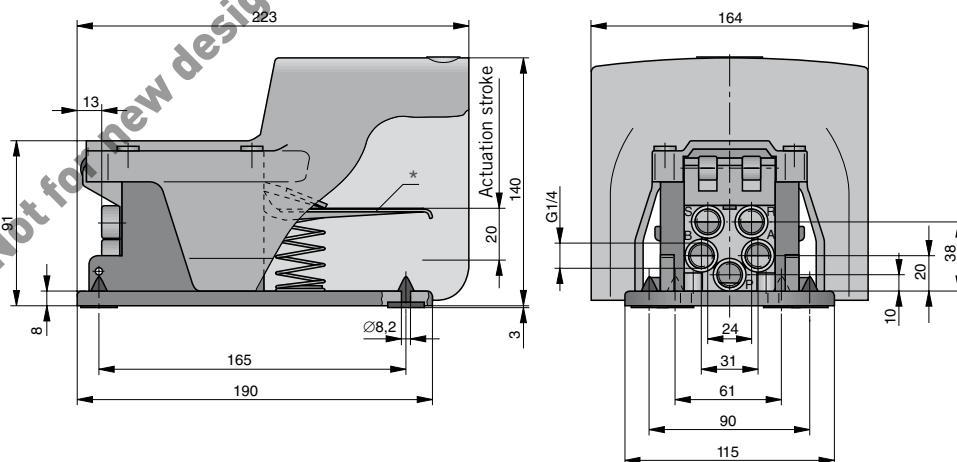

Dimensions in mm

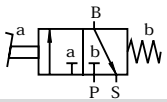
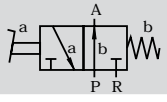
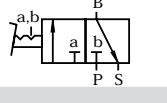
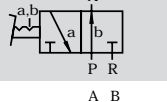
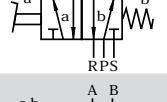
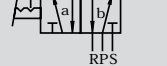

**Order Instructions – 3/2 and 5/2 Way Valves**

Actuation	Symbol	Order Instructions	
		Type	Order No.
Pedal with spring return		F 331RF-08NG*	KZ 4410
		F 331RF-08NO*	KZ 4411
Pedal without reset		F 331-08NG*	KZ 4408
		F 331-08NO*	KZ 4409
Pedal with spring return		F 531RF-08	KZ 4413
Pedal both switch positions indexed		F 531-08	KZ 4412

\* NC – Version normally closed  
 NO – Version normally open

Not for new design - Please contact ORIGA Customer Service: +49 1805 432 777

Dimensions in mm

# 2/2 Way Stop Valves Series ARKV

G1/2 to G2

Actuation System:  
- Pneumatic

## Characteristics

Characteristics	Symbol	Unit	Description				
General Features							
Description	2/2 Way Valve						
Type	Poppet valve normally closed						
Mounting	Direct in piping						
Tube connection	Thread						
Port size			G1/2	G3/4	G1	G1 1/2	G2
Weight (mass)		kg	0.745	1.115	1.365	2.695	4.290
Installation	In any position						
Ambient temperature range	$T_{min/max}$	°C	-20 to +80	Note: Please consult us for operating temperatures below 0° C			
Medium temperature range	$T_{min/max}$	°C	0 to +80				
Medium	Compressed air, neutral gases, presswater (for low flow- und valve closingspeed only)						
Actuating medium	filtered compressed air						
Pneumatic characteristics							
Nominal pressure	$p_n$	bar	6.3				
Operating pressure range	$p_{min/max}$	bar	0 – 10				
Nominal flow	$Q_N$	l/min	2200	5000	6900	22000	40000
Actuation							
Pneumatic	Direct						

### Actuating Pressure – Type: ARKV-15

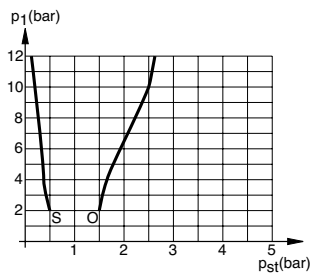

O =  $p_{st\ min}$  to open  
S =  $p_{st\ max}$  to close

### Actuating Pressure – Type: ARKV-20

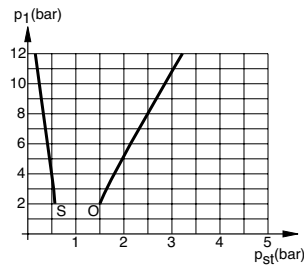

O =  $p_{st\ min}$  to open  
S =  $p_{st\ max}$  to close

### Actuating Pressure – Type: ARKV-25

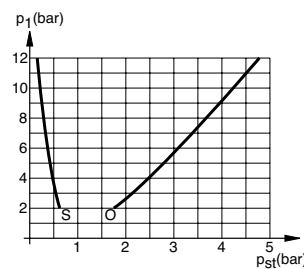

O =  $p_{st\ min}$  to open  
S =  $p_{st\ max}$  to close

### Actuating Pressure – Type: ARKV-40

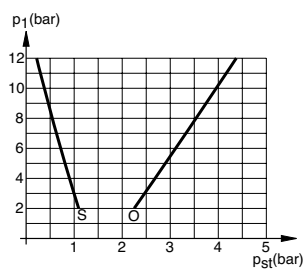

O =  $p_{st\ min}$  to open  
S =  $p_{st\ max}$  to close

### Actuating Pressure – Type: ARKV-50

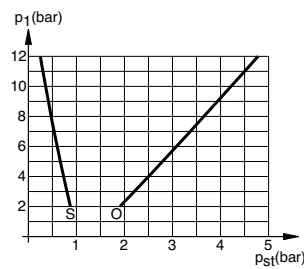

O =  $p_{st\ min}$  to open  
S =  $p_{st\ max}$  to close

Dimensions in mm

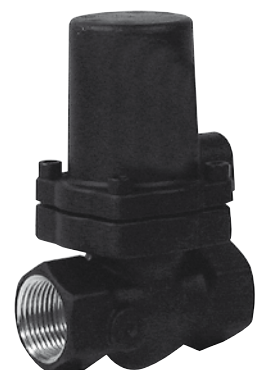

Pneumatically actuated – Type: ARKV...

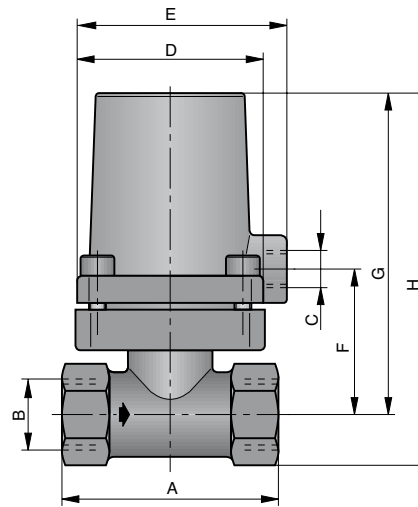

Dimension Table

Type	A	B	C	D	E	F	G	H
ARKV-15 NC	65	G1/2	G1/8	55	61	41.5	95	109.5
ARKV-20 NC	76	G3/4	G1/4	65	75	50	112	129
ARKV-25 NC	91	G1	G1/4	65	75	57	119	139
ARKV-40 NC	123	G1 1/2	G1/4	110	112	67	137	167.5
ARKV-50 NC	150	G2	G1/4	130	134	75	153	190

Order Instructions

Actuation System	Symbol	Order data	
		Type	Order No.
Pneumatic		ARKV-15 NC	PD 07334
		ARKV-20 NC	PD 07580
		ARKV-25 NC	PD 07581
		ARKV-40 NC	PD 07757
		ARKV-50 NC	PD 07765

Dimensions in mm

## Contents

Version	Actuation	Standard / Size	Page		
			Characteristics	Dimension Table	Order Instructions Overview
5/2 and 5/3 Way Valves Series S20	Pneumatic Electrical	VDMA 24563 size 01	118, 119	120	124, 125
5/2 and 5/3 Way Valves Series S20	Pneumatic Electrical	ISO 5599 size 1	118, 119	121	124, 125
5/2 and 5/3 Way Valves Series S20	Pneumatic Electrical	ISO 5599 size 2	118, 119	122	124, 125
5/2 and 5/3 Way Valves Series S20	Pneumatic Electrical	ISO 5599 size 3	118, 119	123	124, 125

## Way Valves to VDMA 24563 and ISO5599

Series S20

Not for new design - Please contact ORIGA Customer Service: +49 1805 432 711

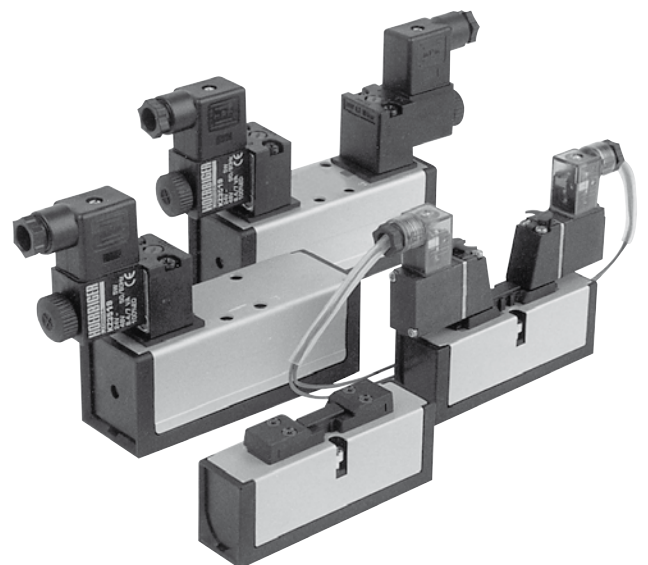

# Way Valves to VDMA 24563 and ISO5599

Series S20

## Characteristics

Characteristics	Symbol	Unit	Series S20 to VDMA 01	
Actuation			Pneumatic	Electrical
General Features				
Type			Ceramic-Spool valve	
Mounting			Via base plate to VDMA 24563	
Tube connection			Base Plate	
Port size			G1/8 or G1/4 (base plate)	
Weight				
– permanent signal		kg	0.130	0.170
– impulse version		kg	0.130	0.210
Installation			In any position	In any position
Ambient temperature range <sup>(1)</sup>	T <sub>min. / max.</sub>	°C	-10 to +60	-10 to +60
Medium temperature range <sup>(1)</sup>	T <sub>min. / max.</sub>	°C	-10 to +55	-10 to +55
Medium			Filtered compressed air	
Lubrication			With or without oil mist lubrication (We recommend the use of mineral oil type VG 32 to ISO 3448)	
Pneumatic Characteristics				
Nominal pressure	p <sub>min. / max.</sub>	bar	6	6
Operating pressure range <sup>(2)</sup>				
– permanent signal version	p <sub>min. / max.</sub>	bar	-0.9 – 10	2 – 10
– impulse version	p <sub>min. / max.</sub>	bar	-0.9 – 10	2 – 10
– with external pilot air	p <sub>min. / max.</sub>	bar	–	-0.9 – 10
Maximum flow	Q <sub>max.</sub>	l/min	1050	1050
Actuation				
Pneumatic			Direct	–
Actuation pressure range				
– permanent signal version	p <sub>min. / max.</sub>	bar	2 – 10	2 – 10
– impulse version	p <sub>min. / max.</sub>	bar	2 – 10	2 – 10
Electrical			Pilot operated	
Voltage type			AC 50/60Hz	Direct current
Nominal voltage				
– Standard version	Un	V	230 ±10%	24 ±10%
– Low wattage version	Un	V	–	–
Initial power consumption				
– Standard version		VA (W)	2	2
– Low wattage version		VA (W)	2	2
Continuous consumption				
– Standard version		VA (W)	–	–
– Low wattage version		VA (W)	–	–
Duty cycle	ED	%	100	
Electrical protection		IP	IP65 to DIN 40050 (applies only to solenoid with connector)	
Connection			Plug to DIN EN 175301-803 form C	

<sup>(1)</sup> Note:  
Please consult us for  
operating temperatures  
below 0° C

<sup>(2)</sup> 16 bar Version for  
valves to ISO 5599  
size 1, 2, 3 on request

<sup>(4)</sup> Low wattage version  
connector DIN EN  
175301-803 form A



Series S20 to ISO 5599					
Size 1		Size 2		Size 3	
Pneumatic	Electrical	Pneumatic	Electrical	Pneumatic	Electrical
Ceramic-Spool valve					
via base plate to ISO5599					
Base plate					
G1/4 (Base plate)		G3/8 (Base plate)		G1/2 (Base plate)	
0.350	0.410	0.600	0.650	1.100	1.150
0.350	0.450	0.600	0.700	1.100	1.200
In any position	In any position	In any position	In any position	In any position	In any position
-10 to +60	-10 to +60	-10 to +60	-10 to +60	-10 to +60	-10 to +60
-10 to +60	-10 to +60	-10 to +60	-10 to +60	-10 to +60	-10 to +60
Filtered compressed air					
With or without oil mist lubrication (We recommend the use of mineral oil type VG 32 to ISO 3448)					
6	6	6	6	6	6
-0.9 – 12	2 – 12	-0.9 – 12	2 – 12	-0.9 – 12	2 – 12
-0.9 – 12	2 – 12	-0.9 – 12	2 – 12	-0.9 – 12	2 – 12
–	-1 – 12	–	1 – 12	–	-1 – 12
1680	1680	4320	4320	6540	6540
Direct	–	Direct	–	Direct	–
2 – 12	2 – 10	2 – 12	2 – 10	2 – 12	2 – 10
2 – 12	2 – 10	2 – 12	2 – 10	2 – 12	2 – 10
Pilot operated					
Alternating current 50/60Hz		Direct current			
230 ±10%		24 ±10%		other voltages	
230 ±10%		24 ±10%		on request	
11		4.8			
7.8		2.7			
8.5		4.8			
4.9		2.7			
100					
IP65 to DIN 40050 (applies only to solenoid with connector)					
Plug to DIN EN 175301-803 form B – industrial standard (4)					

# 5/2 and 5/3 Way Valves Series S20

to VDMA 24563  
Size 01

**Actuation systems:**  
– Pneumatic  
– Electrical pilot operated

**Versions:**  
– With external pilot air  
– With biased position

## Weight (mass) kg

Description	Type	Weight (mass)	* Type supplements for version with middle position
Pneumatic, by permanent signal	S20 561R..-01*	0.130	G = middle position closed
Pneumatic, by impulse	S20 561-01	0.130	E = middle position exhausted
Electrical, by permanent signal	S20 581R..-01*	0.170	B = middle position pressurized
Electrical, by permanent signal	S20 581S-R..-01*	0.170	
Electrical, by impulse	S20 581-01	0.210	
– with biased position	S20 582-01	0.210	
Electrical, by impulse	S20 581S-01	0.210	

## Pneumatically actuated – Type: S20 561...-01

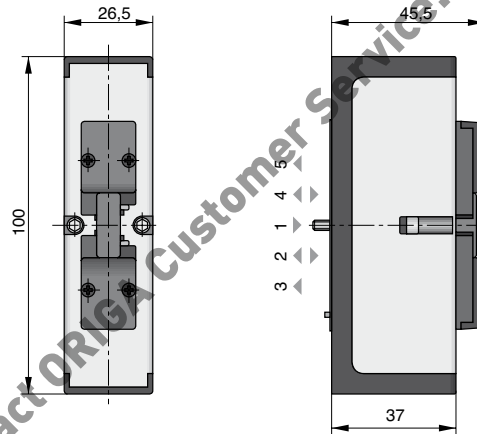

## Electrical pilot operated – Type: S20 581...-01-..., S20 582...-01-..., S20 581S...-01-..

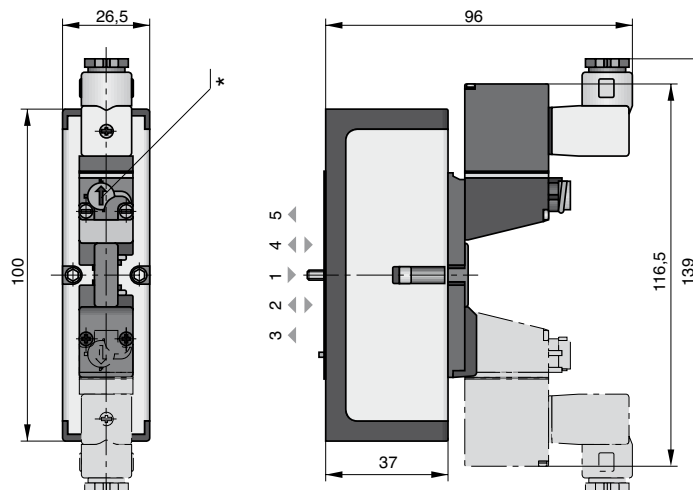

\* Manual override

**The delivery includes:**  
1 Valve with mounting screws  
1 Gasket



Overview and order instructions see page 124, 125

Dimensions in mm

**Weight (mass) kg**

Description	Type	Weight (mass)	* Type supplements for version with middle position
Pneumatic, by permanent signal	S20 561R...-1*	0.350	
Pneumatic, by impulse	S20 561-1	0.350	
Electrical, by permanent signal	S20 581R...-1*	0.410	G = middle position closed
Electrical, by permanent signal	S20 581S-R...-1*	0.410	E = middle position exhausted
Electrical, by impulse	S20 581-1	0.450	B = middle position pressurized
- with biased position	S20 582-1	0.450	
Electrical, by impulse	S20 581S-1	0.450	

# 5/2 and 5/3 Way Valves Series S20

to ISO 5599 size 1

**Actuation systems:**  
 - Pneumatic  
 - Electrical pilot operated

**Versions:**  
 - With external pilot air  
 - With biased position  
 - Low wattage version

**Pneumatically actuated – Type: S20 561...-1**

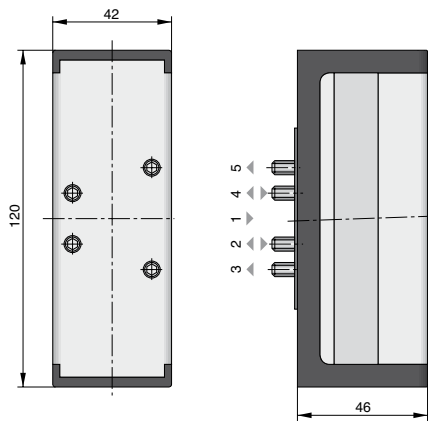

**Electrical pilot operated  
 Type: S20 581...-1..., S20 582-1..., S20 581S...-1...**

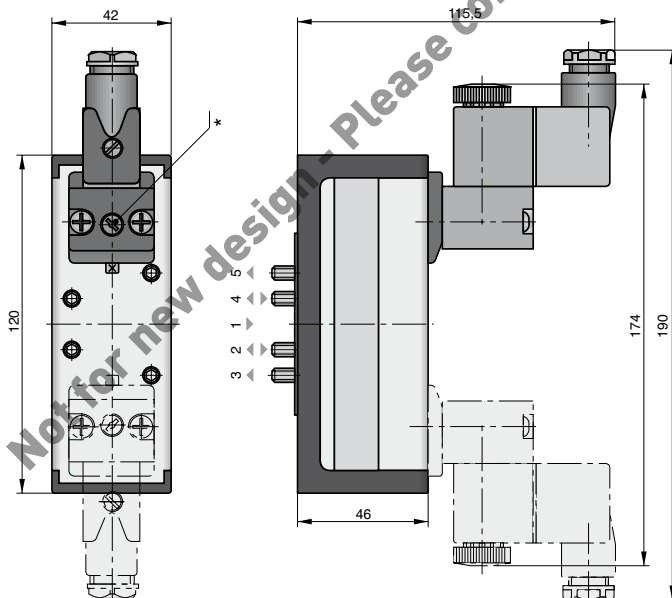

**Magnet for low wattage version**

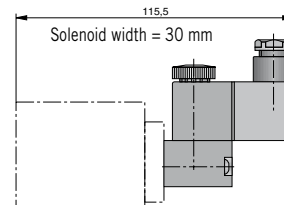

**The delivery includes:**  
 1 Valve with mounting screws  
 1 Gasket

\* Manual override

Overview and order instructions see page 124, 125

Dimensions in mm

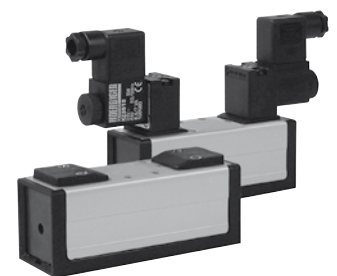

# 5/2 and 5/3 Way Valves Series S20

to ISO 5599  
size 2

**Actuation systems:**  
 - Pneumatic  
 - Electrical pilot operated

**Versions:**  
 - With external pilot air  
 - With biased position  
 - Low wattage version

### Weight (mass) kg

Description	Type	Weight (mass)	* Type supplements for version with middle position
Pneumatic, by permanent signal	S20 561R..-2*	0.600	G = middle position closed E = middle position exhausted B = middle position pressurized
Pneumatic, by impulse	S20 561-2	0.600	
Electrical, by permanent signal	S20 581R..-2*	0.650	
Electrical, by permanent signal	S20 581S-R..-2*	0.650	
Electrical, by impulse	S20 581-2	0.700	
- with biased position	S20 582-2	0.700	
Electrical, by impulse	S20 581S-2	0.700	

### Pneumatically actuated – Type: S20 561...-2

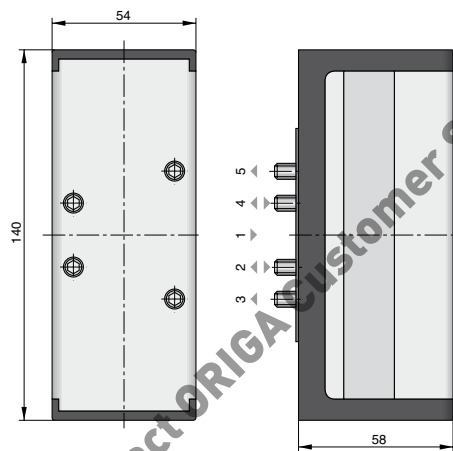

### Electrical pilot operated Type: S20 581...-2-..., S20 582-2-..., S20 581S...-2-..

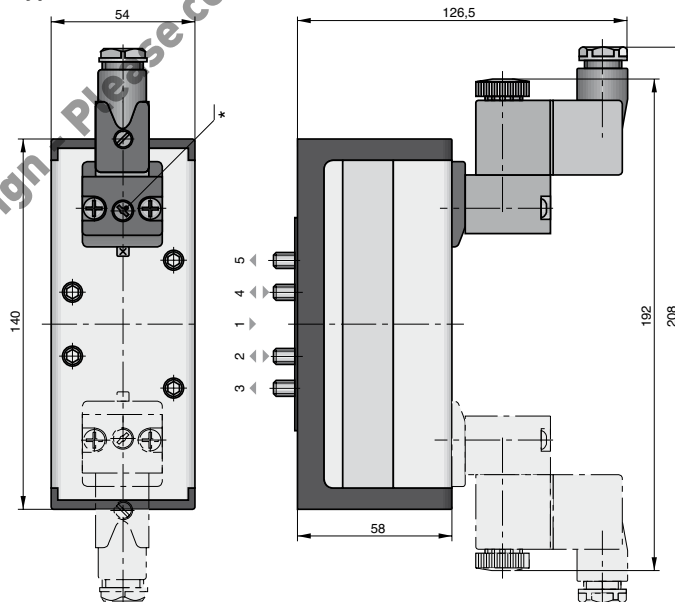

### Magnet for low wattage version

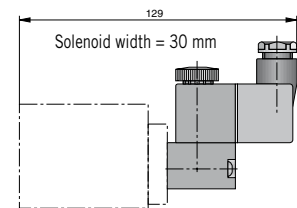

**The delivery includes:**  
 1 Valve with mounting screws  
 1 Gasket

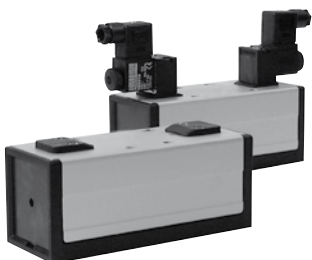

\* Manual override

Overview and order instructions see page 124, 125

Dimensions in mm

**Weight (mass) kg**

Description	Type	Weight (mass)	* Type supplements for version with middle position
Pneumatic, by permanent signal	S20 561R...-3*	1.100	G = middle position closed
Pneumatic, by impulse	S20 561-3	1.100	E = middle position exhausted
Electrical, by permanent signal	S20 581R...-3*	1.150	B = middle position pressurized
Electrical, by permanent signal	S20 581S-R...-3*	1.150	
Electrical, by impulse	S20 581-3	1.200	
– with biased position	S20 582-3	1.200	
Electrical, by impulse	S20 581S-3	1.200	

# 5/2 and 5/3 Way Valves Series S20

to ISO 5599 size 3

**Actuation systems:**

- Pneumatic
- Electrical pilot operated

**Versions:**

- With external pilot air
- With biased position
- Low wattage version

**Pneumatically actuated – Type: S20 561...-3**

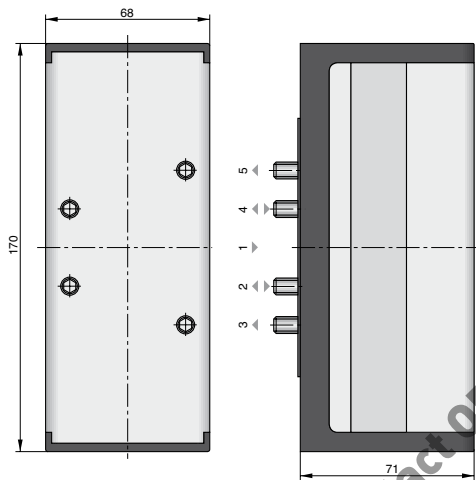

**Electrical pilot operated – Type: S20 581...-3**

**Magnet for low wattage version**

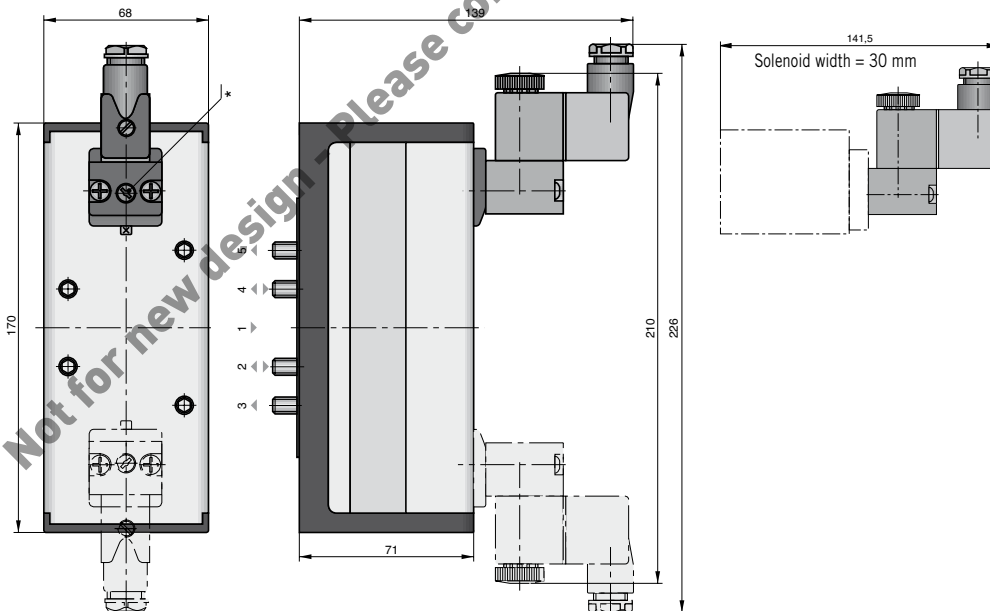

\* Manual override

Overview and order instructions see page 124, 125

Dimensions in mm

**The delivery includes:**

- 1 valve with mounting screws
- 1 Gasket

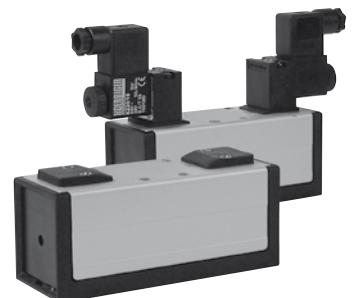

**Order Instructions – 5/2 Way Valves**

Actuation	Symbol	Standard / Size	Order Instructions		Page
			Type	Order No.	
Pneumatic by permanent signal, spring return		VDMA 24563 Gr.01	S20 561RF-01	PA 12891	120
		ISO 5599 Größe1	S20 561RF-1	PA 12869	121
		ISO 5599 size 2	S20 561RF-2	PA 16425	122
		ISO 5599 size 3	S20 561RF-3	PA 16426	123
Pneumatic by permanent signal, air spring return		VDMA 24563 Gr.01	S20 561R-01	PA 12892	120
		ISO 5599 size 1	S20 561R-1	PA 12870	121
		ISO 5599 size 2	S20 561R-2	PA 16428	122
		ISO 5599 size 3	S20 561R-3	PA 16429	123
Pneumatic by impulse		VDMA 24563 Gr.01	S20 561-01	PA 12893	120
		ISO 5599 size 1	S20 561-1	PA 12868	121
		ISO 5599 size 2	S20 561-2	PA 16422	122
		ISO 5599 size 3	S20 561-3	PA 16423	123
Pneumatic by impulse with biased position		VDMA 24563 Gr.01	S20 562-01	PA 12908	120
		ISO 5599 size 1	S20 562-1	PA 12905	121
		ISO 5599 size 2	S20 562-2	PA 12906	122
		ISO 5599 size 3	S20 562-3	PA 12907	123
Electrical by permanent signal, spring return  with external pilot air		VDMA 24563 Gr.01	S20 581RF-01-..	PA 12886-..33	120
		ISO 5599 size 1	S20 581RF-1-..	PA 12875-..33	121
		ISO 5599 size 2	S20 581RF-2-..	PA 16441-..33	122
		ISO 5599 size 3	S20 581RF-3-..	PA 16442-..33	123
		VDMA 24563 Gr.01	S20 581S-RF-01-..	PA 12896-..33	120
		ISO 5599 size 1	S20 581S-RF-1-..	PA 12882-..33	121
		ISO 5599 size 2	S20 581S-RF-2-..	PA 16456-..33	122
		ISO 5599 size 3	S20 581S-RF-3-..	PA 16462-..33	123
Electrical by permanent signal, air spring return		VDMA 24563 Gr.01	S20 581R-01-..	PA 12887-..33	120
		ISO 5599 size 1	S20 581R-1-..	PA 12876-..33	121
		ISO 5599 size 2	S20 581R-2-..	PA 16444-..33	122
		ISO 5599 size 3	S20 581R-3-..	PA 16445-..33	123
Electrical by impulse  with external pilot air		VDMA 24563 Gr.01	S20 581-01-..	PA 12888-..33	120
		ISO 5599 size 1	S20 581-1-..	PA 12874-..33	121
		ISO 5599 size 2	S20 581-2-..	PA 16438-..33	122
		ISO 5599 size 3	S20 581-3-..	PA 16439-..33	123
		VDMA 24563 Gr.01	S20 581S-01-..	PA 12898-..33	120
		ISO 5599 size 1	S20 581S-1-..	PA 12880-..33	121
		ISO 5599 size 2	S20 581S-2-..	PA 16454-..33	122
		ISO 5599 size 3	S20 581S-3-..	PA 16460-..33	123
Electrical by impulse with biased position		VDMA 24563 Gr.01	S20 582-01-..	PA 12904-..33	120
		ISO 5599 size 1	S20 582-1-..	PA 12901-..33	121
		ISO 5599 size 2	S20 582-2-..	PA 12902-..33	122
		ISO 5599 size 3	S20 582-3-..	PA 12903-..33	123

Type and additional order instructions see page 125

### Order Instructions – 5/3 Way Valves

Actuation	Symbol	Standard / Size	Order Instructions		Page		
			Type	Order No.			
Pneumatic by permanent signal, spring return to middle position		VDMA 24563 Gr. 01	S20 561RFG-01	PA 12894	120		
		ISO 5599 size 1	S20 561RFG-1	PA 12871	121		
		ISO 5599 size 2	S20 561RFG-2	PA 16431	122		
		ISO 5599 size 3	S20 561RFG-3	PA 16432	123		
		ISO 5599 size 1	S20 561RFB-1	PA 12873	121		
		ISO 5599 size 2	S20 561RFB-2	PA 16437	122		
		VDMA 24563 Gr. 01	S20 561RFE-01	PA 12895	120		
		ISO 5599 size 1	S20 561RFE-1	PA 12872	121		
		ISO 5599 size 2	S20 561RFE-2	PA 16434	122		
		ISO 5599 size 3	S20 561RFE-3	PA 16435	123		
		Electrical by permanent signal, spring return to middle position		VDMA 24563 Gr. 01	S20 581RFG-01	PA 12889-..33	120
				ISO 5599 size 1	S20 581RFG-1-..	PA 12877-..33	121
ISO 5599 size 2	S20 581RFG-2-..			PA 16447-..33	122		
ISO 5599 size 3	S20 581RFG-3-..			PA 16448-..33	123		
	ISO 5599 size 1		S20 581RFB-1-..	PA 12879-..33	121		
	ISO 5599 size 2		S20 581RFB-2-..	PA 16453-..33	122		
	with external pilot air		VDMA 24563 Gr. 01	S20 581RFE-01	PA 12890-..33	120	
			ISO 5599 size 1	S20 581RFE-1-..	PA 12878-..33	121	
ISO 5599 size 2			S20 581RFE-2-..	PA 16450-..33	122		
ISO 5599 size 3			S20 581RFE-3-..	PA 16451-..33	123		
	ISO 5599 size 1		S20 581S-RFG-01-..	PA 12900-..33	120		
	ISO 5599 size 1		S20 581S-RFG-1-..	PA 12883-..33	121		
	ISO 5599 size 2	S20 581S-RFG-2-..	PA 16457-..33	122			
	ISO 5599 size 3	S20 581S-RFG-3-..	PA 16463-..33	123			
	ISO 5599 size 1	S20 581S-RFB-1-..	PA 12885-..33	121			
	ISO 5599 size 2	S20 581S-RFB-2-..	PA 16459-..33	122			
		VDMA 24563 Gr. 01	S20 581S-RFE-01-..	PA 12899-..33	120		
		ISO 5599 size 1	S20 581S-RFE-1-..	PA 12884-..33	121		
ISO 5599 size 2		S20 581S-RFE-2-..	PA 16458-..33	122			
ISO 5599 size 3		S20 581S-RFE-3-..	PA 16464-..33	123			

Solenoid version	Nominal voltage	Applicable for	Key code
Standard version	230V 50/60Hz	110 V =	61
	24V =	60V 50/60Hz	02
Low wattage version	24V =		13
	230V 50/60Hz		69
Other voltages on request			





## Contents

Version	Standard / Size	Page	
		Dimensions	Order Instructions Overview
Single Base Plates G1/8, G1/4	VDMA 24563 size 01	128	128
Modules for Base Plate Combinations G1/8, G1/4	VDMA 24563 size 01	129	129
Single Base Plates	ISO 5599 size 1, 2, 3	130, 131	130, 131
Base Plate combinations	ISO 5599 size 1, 2, 3	132, 133	132, 133

## Single Base Plates

– to VDMA 24563,  
Size 01

– to ISO 5599  
Size 1, 2, 3

Not for new design - Please contact ORIGA Customer Service: +49 1805 222777

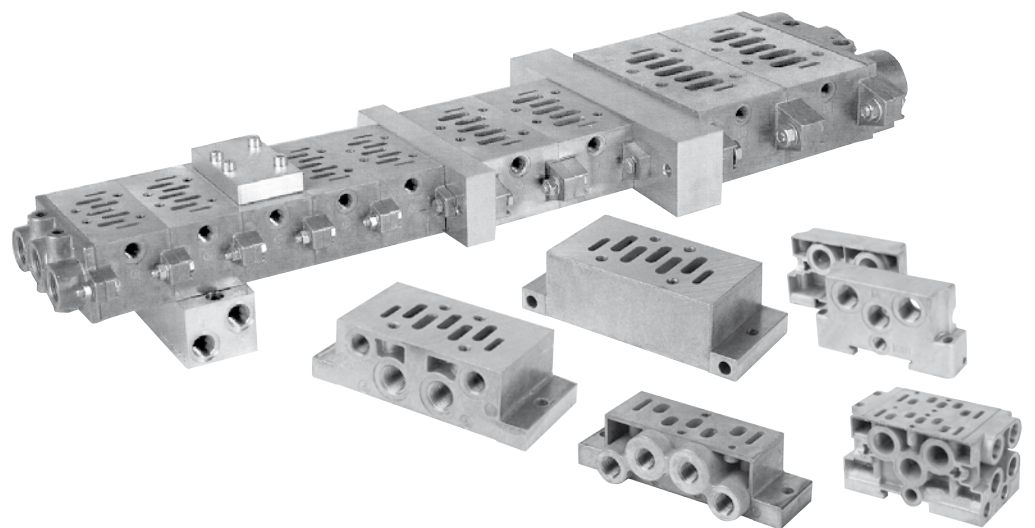

# Single Base Plates

to VDMA 24563  
Size 01, Form A

Port Size:  
G1/8  
G1/4

Single Base Plates Form A – Connection size G1/8 – Type: S20-01-1/8-A

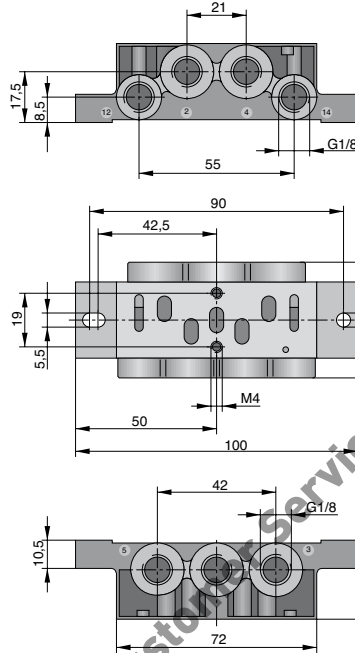

Single Base Plates Form A – Connection size G1/4 – Type: S20-01-1/4-A

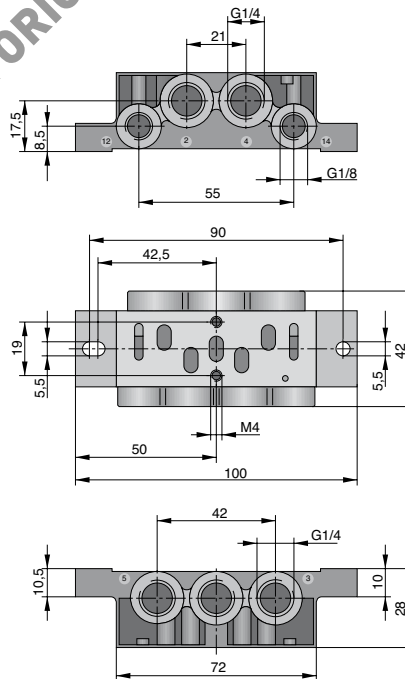

Not for new design - Please contact ORIGINAL Customer Service: +49 1805 432 777

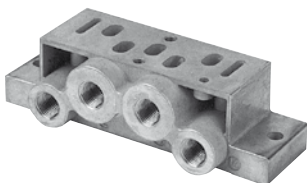

### Order Instructions

Description	Port size	Weight (kg)	Order Instructions	
			Type	Order No.
Single Base Plate	G1/8	0.070	S20-01-1/8-A	KL8004
	G1/4	0.120	S20-01-1/4-A	KL8005

Dimensions in mm

### End Plate Set Form D for Intermediate Plate

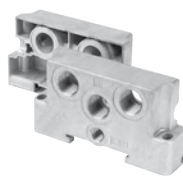
Description	Size	Weight (kg)	Order Instructions		Figure
			Type	Order No.	
End Plate set Form D	VDMA 01	0.220	S20-01-D	KL8008	

**The delivery includes:** End Plate set, completely with screws

### Intermediate Plate Form C

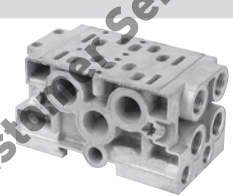
Description	Port (Port size)	Weight (kg)	Order Instructions		Figure
			Type	Order No.	
Intermediate Plate form C	VDMA 01 (G1/8)	0.080	S20-01-C	KL8006	
Intermediate Plate form C	VDMA 01 (G1/4)	0.100	S20-01-C	KL8007	

**The delivery includes:** Intermediate Plate, completely with O-Rings and screws

### Dummy plate

Description	size	Weight (kg)	Order Instructions		Figure
			Type	Order No.	
Dummy Plate	VDMA 01	0.050	S20-01-BP	KL8009	

**The delivery includes:** Dummy Plate with gasket and screws

## Modules for Base Plate Combinations

to VDMA 24563 size 01

#### Modules:

- End Plate set, Form D, for Intermediate Plate Form C
- Angle base plate, Form E, for Intermediate Plate Form C
- Accessories

#### Port Size:

- G1/8
- G1/4

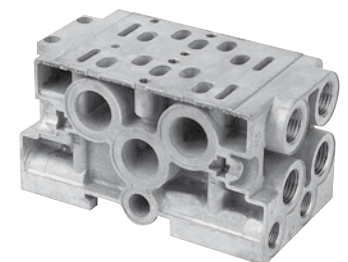

Dimensions in mm

# Base Plates

to ISO 5599  
Size 1, 2, 3

Versions:  
– Single Base Plates  
to VDMA 24345 Form A

## Single Base Plates Form A – Type: S9.-A

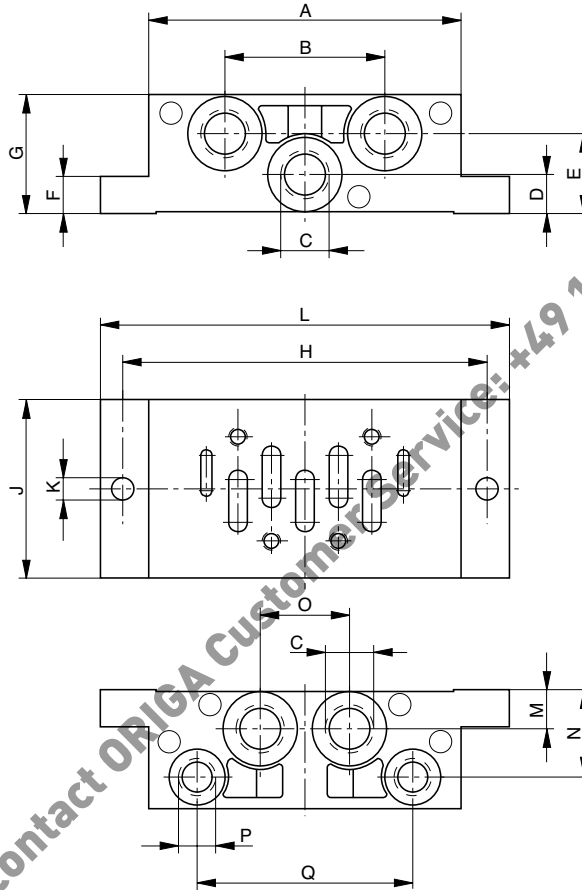

Dimension Table Single Base Plates Form A

ISO-Size	A	B	C	D	E	F	G	H
1	84	43	G1/4	10.5	21.5	10	32	98
2	95	56	G3/8	14	26	13	40	112
3	119	68	G1/2	17	17	18	32	136

ISO-Size	J	K	L	M	N	O	P	Q
1	48	5,5	110	10.5	23,5	24	G1/8	58
2	57	6,6	124	14	30	30	G1/8	74
3	71	6,6	149	17	22	32	G1/8	90

### Order Instructions Form A

ISO-Size	Weight (kg)	Order Instructions	
		Type	Order No.
1	0.160	S9-1-A	KX 9076
2	0.280	S9-2-A	KX 9433
3	0.570	S9-3-A	KX 9434

Dimensions in mm

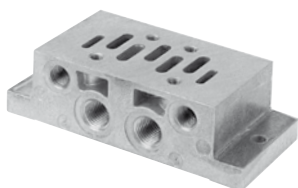

Not for new design - please contact ORIGA Customer Service: +49 1805 432 777

Single Base Plates Form B – Type: S9 --B

# Base Plates

to ISO 5599  
Size 1, 2, 3

Versions:  
– Single Base Plates  
to VDMA 24345 Form B

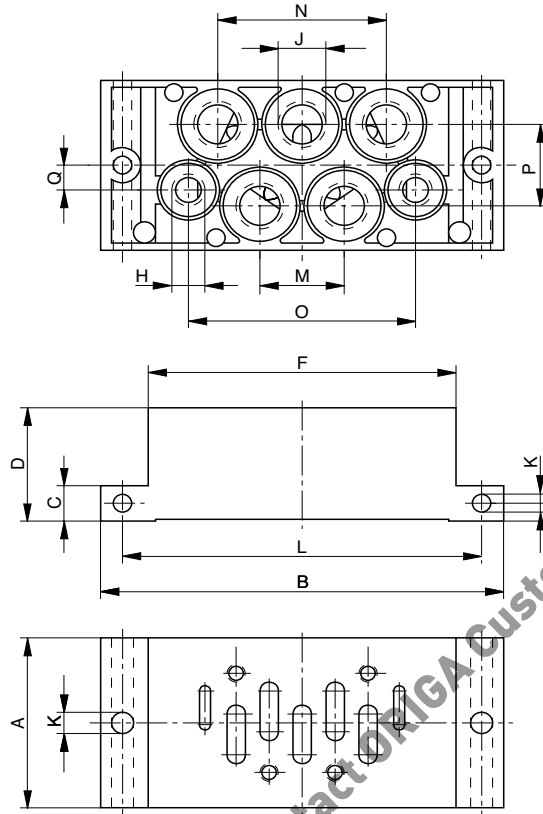

Dimension Table Single Base Plates Form B

ISO-Size	A	B	C	D	E	F	H	J
1	46	110	10	30	5	84	G1/8	G1/4
2	56	124	13	35	6,5	95	G1/8	G3/8
3	71	149	18	32	9	119	G1/8	G1/2

ISO-Size	K	L	M	N	O	P	Q
1	5,5	98	23	46	62	23	7.5
2	6,6	112	28	56	73	27	7.5
3	6,6	136	34	68	90	35	10

Order Instructions Form B

ISO-Size	Weight (kg)	Order Instructions	
		Type	Order No.
1	0.370	S9-1-B	KX 9077
2	0.590	S9-2-B	KX 9436
3	0.900	S9-3-B	KX 9437

Dimensions in mm

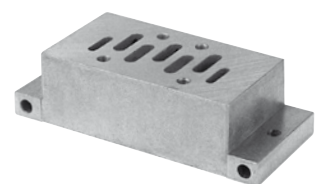

# Modules for Base Plate Combinations

to ISO 5599  
Size 1, 2, 3

- Versions to VDMA 24345
- End Plate set, Form D, for Intermediate Plate, Form C
  - Intermediate Plate, Form C
  - Angle Base Plates Form E for for Intermediate Plate Form C
  - Accessories

## End Plate Set Form D for Intermediate Plate – Order Instructions and Weight

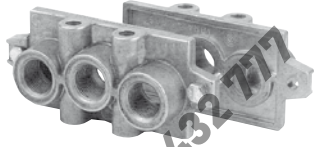
ISO-Size	Weight (kg)	Order Instructions		Figure
		Type	Order No.	
1	0.210	S9-1-D	KX 9078	
2	0.360	S9-2-D	KX 9421	
3	0.680	S9-3-D	KX 9422	

The delivery includes: End Plate Set, completely with screws

## Intermediate Plate Form C – Order Instructions and Weight

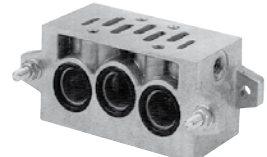
ISO-Size	Weight (kg)	Order Instructions		Figure
		Type	Order No.	
1	0.240	S9-1-C	KX 9079	
2	0.360	S9-2-C	KX 9419	
3	0.700	S9-3-C	KX 9420	

The delivery includes: Intermediate Plate, completely with O-rings and screws

## Angle Base Plate Form E for Intermediate Plate Form C

Dimension Table

Figure

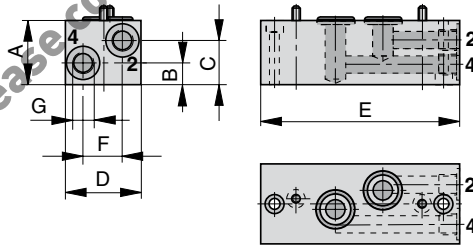

## Order Instructions and Dimension Table (mm)

Order Instructions		ISO-Size	A	B	C	D	E	F	G
Type	Order No.								
S9-1-E	KX 9081	1	37	12	25	42	110	22	G1/4
-	-	2	-	-	-	-	-	-	-
S9-3-E	KX 9425	3	45	17	29	70	190	36	G1/2

The delivery includes: Angle Base Plate, completely with O-rings and screws

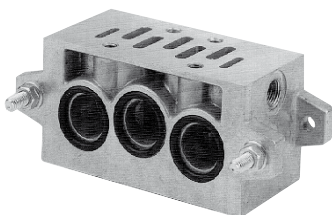

Dimensions in mm

**Adapter Plate for Linkage of ISO-Sizes 1, 2, 3 – Dimension Table and Order Instructions**

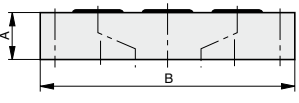
Order Instructions		for ISO Size	A	B	Width	Figure
Type	Order No.					
S9-1-2-KP	KX 9430	1 to 2	20	135	45	
S9-2-3-KP	KX 9431	2 to 3	25	190	55	
S9-1-3-KP	KX 9432	1 to 3	35	190	50	

**The delivery includes:** Adapter Plate with O-Rings and washers

**Dummy Plate – Dimension Table and Order Instructions**

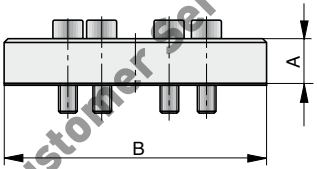
Order Instructions		for ISO Size	A	B	Width	Figure
Type	Order No.					
S9-1-BP	KX 9082	1	12	70	40	
S9-2-BP	KX 9423	2	12	90	55	
S9-3-BP	KX 9424	3	12	110	70	

**The delivery includes:** Dummy Plate with gasket and screws

**Plug – Order Instructions**

Order Instructions		for ISO Size	Figure
Type	Order No.		
S9-1-VS	KX 5789	1	
S9-2-VS	KX 9426	2	
S9-3-VS	KX 9427	3	

Not for new design - Please contact ORIGA Customer Service: +49 1805 432 777

Dimensions in mm

# Connection-platten

to ISO 5599  
size 1, 2, 3

## Versions

to VDMA 24345

- End Plate set Form D for Intermediate Plate Form C
- Intermediate Plate Form C
- Angle Base Plates Form E for Intermediate Plate Form C
- Accessories

Example of Plate Combination

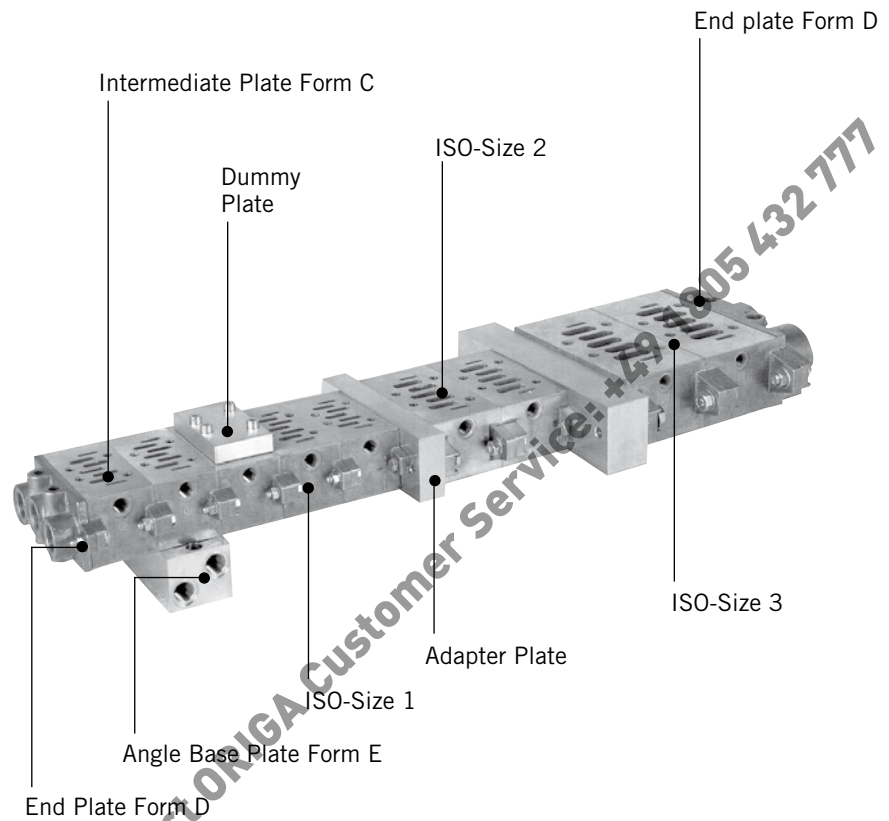



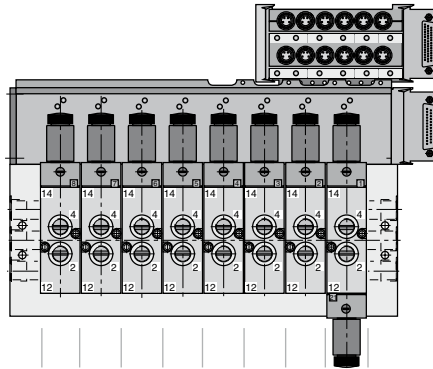

# Ordering Code

*neutral  
for Valve Islands*

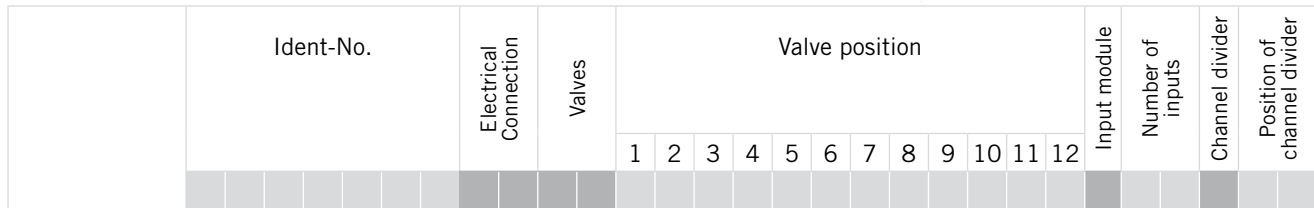

04 06 08 10 12  
even number of valve positions only

Important: Please specify the code for the desired valve types

Input Modules	
K	Pins IP20
S	Plug M8 IP65
04-08-12	Number of inputs
16-20-24	
28-32	

Dual Pressure Operating	
J	with channel divider in Connection 1 (P)
01 - 11	Position of channel divider to valve position

Valve Islands – Sizes	
PA 10381	Type: IM20-1/8 Connections: G1/8: valve outlets G1/4: base plate
PA12867	Type: IM20-1/4 Connections: G1/4: valve outlets G3/8: base plate

Electrical Connection	
Multipol-Version	
DS	with sub-D-conn.
HI	with industrial connector

Valves	
04	to 4 valves
06	5 and 6 valves
08	7 and 8 valves
10	9 and 10 valves
12	11 and 12 valves
14	13 and 14 valves
16	15 and 16 valves

Ordering Code for Valves and Cover Plates		
Code	Symbol	Description
A	–	Blanking plate on valve position
M		5/2 way solenoid valve, permanent signal with spring return Type: S9 581RF-..
J		5/2 way solenoid valve, impulse Type: S9 581RF-..
G		5/2 way solenoid valve, spring return to middle position, middle position closed Type: S9 581RFG-..
B		5/2 way solenoid valve, spring return to middle position, middle position pressurized Type: S9 581RFB-..
E		5/2 way solenoid valve, spring return to middle position, middle position exhausted Type: S9 581RFE-..





# Parker Worldwide

**AE – UAE, Dubai**  
Tel: +971 4 8127100  
parker.me@parker.com

**AR – Argentina, Buenos Aires**  
Tel: +54 3327 44 4129

**AT – Austria, Wiener Neustadt**  
Tel: +43 (0)2622 23501-0  
parker.austria@parker.com

**AT – Eastern Europe, Wiener Neustadt**  
Tel: +43 (0)2622 23501 900  
parker.easteurope@parker.com

**AU – Australia, Castle Hill**  
Tel: +61 (0)2-9634 7777

**AZ – Azerbaijan, Baku**  
Tel: +994 50 2233 458  
parker.azerbaijan@parker.com

**BE/LU – Belgium, Nivelles**  
Tel: +32 (0)67 280 900  
parker.belgium@parker.com

**BR – Brazil, Cachoeirinha RS**  
Tel: +55 51 3470 9144

**BY – Belarus, Minsk**  
Tel: +375 17 209 9399  
parker.belarus@parker.com

**CA – Canada, Milton, Ontario**  
Tel: +1 905 693 3000

**CH – Switzerland, Etoy**  
Tel: +41 (0) 21 821 02 30  
parker.switzerland@parker.com

**CL – Chile, Santiago**  
Tel: +56 2 623 1216

**CN – China, Shanghai**  
Tel: +86 21 5031 2525

**CZ – Czech Republic, Klecany**  
Tel: +420 284 083 111  
parker.czechrepublic@parker.com

**DE – Germany, Kaarst**  
Tel: +49 (0)2131 4016 0  
parker.germany@parker.com

**DK – Denmark, Ballerup**  
Tel: +45 43 56 04 00  
parker.denmark@parker.com

**ES – Spain, Madrid**  
Tel: +34 902 33 00 01  
parker.spain@parker.com

**FI – Finland, Vantaa**  
Tel: +358 (0)20 753 2500  
parker.finland@parker.com

**FR – France, Contamine s/Arve**  
Tel: +33 (0)4 50 25 80 25  
parker.france@parker.com

**GR – Greece, Athens**  
Tel: +30 210 933 6450  
parker.greece@parker.com

**HK – Hong Kong**  
Tel: +852 2428 8008

**HU – Hungary, Budapest**  
Tel: +36 1 220 4155  
parker.hungary@parker.com

**IE – Ireland, Dublin**  
Tel: +353 (0)1 466 6370  
parker.ireland@parker.com

**IN – India, Mumbai**  
Tel: +91 22 6513 7081-85

**IT – Italy, Corsico (MI)**  
Tel: +39 02 45 19 21  
parker.italy@parker.com

**JP – Japan, Tokyo**  
Tel: +(81) 3 6408 3901

**KR – South Korea, Seoul**  
Tel: +82 2 559 0400

**KZ – Kazakhstan, Almaty**  
Tel: +7 7272 505 800  
parker.easteurope@parker.com

**LV – Latvia, Riga**  
Tel: +371 6 745 2601  
parker.latvia@parker.com

**MX – Mexico, Apodaca**  
Tel: +52 81 8156 6000

**MY – Malaysia, Shah Alam**  
Tel: +60 3 7849 0800

**NL – The Netherlands, Oldenzaal**  
Tel: +31 (0)541 585 000  
parker.nl@parker.com

**NO – Norway, Ski**  
Tel: +47 64 91 10 00  
parker.norway@parker.com

**NZ – New Zealand, Mt Wellington**  
Tel: +64 9 574 1744

**PL – Poland, Warsaw**  
Tel: +48 (0)22 573 24 00  
parker.poland@parker.com

**PT – Portugal, Leca da Palmeira**  
Tel: +351 22 999 7360  
parker.portugal@parker.com

**RO – Romania, Bucharest**  
Tel: +40 21 252 1382  
parker.romania@parker.com

**RU – Russia, Moscow**  
Tel: +7 495 645-2156  
parker.russia@parker.com

**SE – Sweden, Spånga**  
Tel: +46 (0)8 59 79 50 00  
parker.sweden@parker.com

**SG – Singapore**  
Tel: +65 6887 6300

**SK – Slovakia, Banská Bystrica**  
Tel: +421 484 162 252  
parker.slovakia@parker.com

**SL – Slovenia, Novo Mesto**  
Tel: +386 7 337 6650  
parker.slovenia@parker.com

**TH – Thailand, Bangkok**  
Tel: +662 717 8140

**TR – Turkey, Istanbul**  
Tel: +90 216 4997081  
parker.turkey@parker.com

**TW – Taiwan, Taipei**  
Tel: +886 2 2298 8987

**UA – Ukraine, Kiev**  
Tel +380 44 494 2731  
parker.ukraine@parker.com

**UK – United Kingdom, Warwick**  
Tel: +44 (0)1926 317 878  
parker.uk@parker.com

**US – USA, Cleveland**  
Tel: +1 216 896 3000

**VE – Venezuela, Caracas**  
Tel: +58 212 238 5422

**ZA – South Africa, Kempton Park**  
Tel: +27 (0)11 961 0700  
parker.southafrica@parker.com

European Product Information Centre  
Free phone: 00 800 27 27 5374  
(from AT, BE, CH, CZ, DE, DK, ES, FI, FR, IE,  
IT, NL, NO, PL, PT, RU, SE, UK, ZA)

