

Modular Pneumatic Linear Drive Systems

ORIGA SYSTEM PLUS

aerospace
climate control
electromechanical
filtration
fluid & gas handling
hydraulics
pneumatics
process control
sealing & shielding



ORIGA

ENGINEERING YOUR SUCCESS.

Parker Origa Origa rodless pneumatic cylinders are the first rodless cylinders that have been approved for use in potentially explosive atmospheres in Equipment Group II, Category 2 GD.

The Cylinders are to the ATEX Certification 94/9/EG (ATEX 95) for Pneumatic Components.

For the different classifications and details please see data sheet P-1.10.020E and P-1.45.105E.

You will find further information on the ATEX Directives in our brochure P-A5P060E.

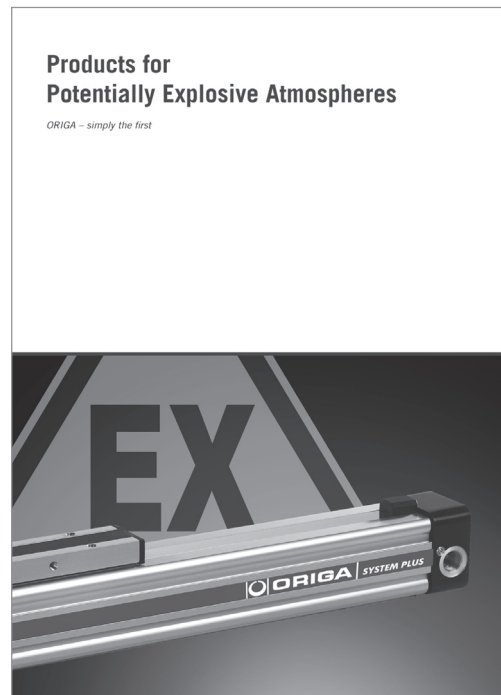

Special Versions



for use in Ex-Areas



for Clean Room Applications certified to DIN EN ISO 14644-1



Stainless steel version for special applications

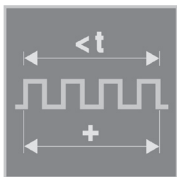

with special pneumatic cushioning system for cycle time optimization, for \varnothing 16 to 50 mm – on request



High Temperature Version for temperatures up to $+120^{\circ}\text{C}$

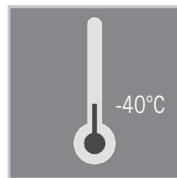

Low Temperature Version for temperatures up to -40°C



Slow Speed Version $v = 0.005 - 0.2 \text{ m/s}$

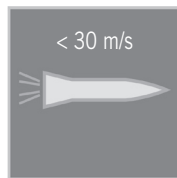

High Speed Version $v_{\text{max.}} = 30 \text{ m/s}$



Cylinders with extreme long strokes Stroke length up to 41 m

Note:
For guidance on the application of the information in this catalogue please refer to the inner back cover.

Contents Linear Drives



	Data Sheet	Page		Data Sheet	Page
Introduction – OSP Concept	P-1.01.001E	1-3	OSP – Accessories		
Modular Components Overview	P-1.01.002E	4-5	Overview	P-1.45.001E	83-84
Control Examples for OSP-P	P-1.01.002E	6	Clevis Mounting	P-1.45.002E	85-86
OSP-P Application examples	P-1.01.002E	7	End Cap Mounting	P-1.45.003E	87
			Mid-Section Support	P-1.45.004E	88
			Mountings for Linear Drives fitted with OSP-Guides	P-1.45.005E	89-97
Rodless Pneumatic Cylinders			Inversion Mounting	P-1.45.006E	99
Overview	P-1.10.001E	9-13	Adaptor Profile	P-1.45.007E	100
Series OSP-P \varnothing 10 to 80 mm	P-1.10.001E	15-21, 24	T-Slot Profile	P-1.45.008E	101
Integrated Valves VOE	P-1.10.002E	22-24	Connection Profile	P-1.45.009E	102
NEW Long-Stroke Cylinders	P-1.10.002	25-29	Duplex Connection	P-1.45.011E	103
Clean Room Cylinders	P-1.10.003E	31-34	Multiplex Connection	P-1.45.012E	104
ATEX-Version $\text{\textcircled{Ex}}$	P-1.10.020E	35-36	Magnetic Switches		
ATEX-Version $\text{\textcircled{Ex}}$ Plain Bearing Guide SLIDELINE	P-1.10.020E	35-36	– Standard Version	P-1.45.100E	105-107
Bi-parting Version	P-1.10.021E	37-38	– T-Slot Version	P-1.45.104E	108-112
			– ATEX-Version $\text{\textcircled{Ex}}$	P-1.45.105E	113-115
			Cable Cover	P-1.45.102E	108
Linear Guides			Displacement Measuring Systems		
Overview	P-1.40.001E	39-40	ORIGA SENSOFLEX		
Plain Bearing Guide SLIDELINE	P-1.40.002E	41-42	Overview	P-1.50.001E	117-118
Roller Guide	P-1.40.003E	43-46	– Series SFI-plus	P-1.50.002E	119-12
POWERSLIDE					
Aluminium-Roller Guide	P-1.40.005E	47-48			
PROLINE					
Aluminium-Roller Guide	P-1.40.005E	47-48			
– PROLINE with ACTIVE-Brake					
Recirculating Ball Bearing Guide	P-1.40.006E	49-51			
STARLINE					
– Variable Stop VS		52-54			
Recirculating Ball Bearing Guide	P-1.40.007E	55-57			
KF					
– Variable Stop VS		58-60			
Heavy Duty Guide HD	P-1.40.008E	61-63			
– Variable Stop VS		64			
NEW – Intermediate stop module ZSM		65-67			
Brakes					
Overview	P-1.42.001E	65-67			
ACTIVE-Brakes					
ACTIVE-Brake	P-1.42.002E	71-74			
– for Standard Cylinder					
Plain Bearing Guide SLIDELINE	P-1.40.002E	41-42			
– with ACTIVE-Brake					
Aluminium-Roller Guide	P-1.40.005E	47-48			
PROLINE with ACTIVE-Brake					
PASSIV-Brakes					
Multi-Brake: PASSIVE-Brake with Plain Bearing Guide SLIDELINE	P-1.42.003E	75-78			
Multi-Brake: PASSIVE-Brake with Aluminium-Roller Guide PROLINE	P-1.42.004E	79-81			

ONE CONCEPT – THREE DRIVE OPTIONS

Based on the ORIGA rodless cylinder, proven in world wide markets, Parker Origa now offers the complete solution for linear drive systems. Designed for absolute reliability, high performance, ease of use and optimised engineering the ORIGA SYSTEM PLUS satisfies even the most demanding applications.

ORIGA SYSTEM PLUS

is a totally modular concept which offers the choice of pneumatic or electric actuation, with guidance and control modules to suit the exact needs of individual installations.

The actuators at the core of the system all have a common aluminium extruded profile, with double dovetail mounting rails on three sides, these

are the principle building blocks of the system to which all modular options are directly attached.



SYSTEM MODULARITY

• Pneumatic Drive

– For all round versatility and convenience, combining ease of control and broad performance capability. Ideally suited for point-to point operations, reciprocating movements and simple traverse / transfer applications.

• Electric Screw Drive

– For high force capability and accurate path and position control.

For additional informations on electrical linear drives, please refer to catalogue P-A4P017E.

• Electric Belt Drive

– For high speed applications, accurate path and position control and longer strokes.

For additional informations on electrical linear drives, please refer to catalogue P-A4P017E.













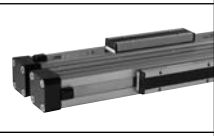

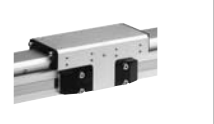
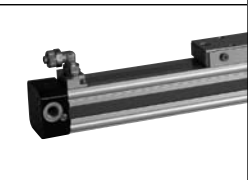





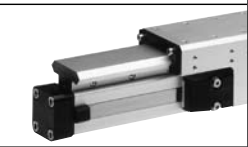
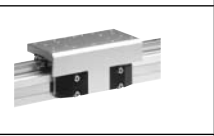
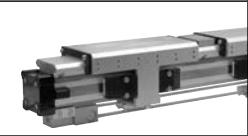

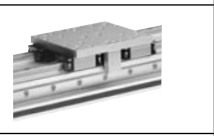
- Different guidance options provide the necessary level of precision, performance and duty for various applications.

- Compact solutions, which are simple to install and can be easily retro-fitted.

- Valves and control options can be directly mounted to the actuator system.

- Diverse mounting options to provide total installation flexibility.

* Information on electrical linear drives series OSP-E, please refer to catalogue P-A4P017E

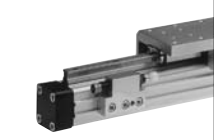
<p>Basic Linear Drive Standard Version</p> <ul style="list-style-type: none"> ● Series OSP-P ● Series OSP-E* <ul style="list-style-type: none"> Belt drive Belt drive with integrated Guides Vertical belt drive with recirculating ball bearing guide ● Series OSP-E* <ul style="list-style-type: none"> Screw drive (Ball Screw, Trapezoidal Screw) 		<p>Duplex Connection</p> <ul style="list-style-type: none"> ● Series OSP-P 	
<p>Air Connection on the End-face or both at One End</p> <ul style="list-style-type: none"> ● Series OSP-P 		<p>Multiplex Connection</p> <ul style="list-style-type: none"> ● Series OSP-P 	
<p>Long-Stroke Cylinders for strokes up to 41 m</p> <ul style="list-style-type: none"> ● Series OSP-P 		<p>Linear Guides – SLIDELINE</p> <ul style="list-style-type: none"> ● Series OSP-P ● Series OSP-E Screw drive* 	
<p>Clean Room Cylinder certified to DIN EN ISO 146644-1</p> <ul style="list-style-type: none"> ● Series OSP-P ● Series OSP-E..SB 		<p>Linear Guides – POWERSLIDE</p> <ul style="list-style-type: none"> ● Series OSP-P ● Series OSP-E Belt drive* ● Series OSP-E Screw drive* 	
<p>Products for ATEX Areas</p> <ul style="list-style-type: none"> ● Series OSP-P Rodless Cylinders 		<p>Linear Guides – PROLINE</p> <ul style="list-style-type: none"> ● Series OSP-P ● Series OSP-E Belt drive* ● Series OSP-E Screw drive* 	
<p>Products for ATEX Areas</p> <ul style="list-style-type: none"> ● Series OSP-P Rodless Cylinders with Linear Guide SLIDELINE 		<p>Linear Guides – STARLINE</p> <ul style="list-style-type: none"> ● Series OSP-P 	
<p>Bi-parting Version</p> <ul style="list-style-type: none"> ● Series OSP-P 		<p>Linear Guides – KF</p> <ul style="list-style-type: none"> ● Series OSP-P 	
<p>Integrated 3/2 Way Valves</p> <ul style="list-style-type: none"> ● Series OSP-P 		<p>Heavy Duty Linear Guides – HD</p> <ul style="list-style-type: none"> ● Series OSP-P ● Series OSP-E Screw drive* 	
<p>Clevis Mounting</p> <ul style="list-style-type: none"> ● Series OSP-P ● Series OSP-E Belt drive* ● Series OSP-E Screw drive* 		<p>Intermediate stop module – ZSM</p> <ul style="list-style-type: none"> ● Series OSP-P 	
<p>End Cap Mounting</p> <ul style="list-style-type: none"> ● Series OSP-P ● Series OSP-E Belt drive* ● Series OSP-E Screw drive* 		<p>Brakes</p> <ul style="list-style-type: none"> ● Active Brakes ● Passive Brakes 	
<p>Mid-Section Support</p> <ul style="list-style-type: none"> ● Series OSP-P ● Series OSP-E Belt drive* ● Series OSP-E Screw drive* 		<p>Magnetic Switches</p> <ul style="list-style-type: none"> ● Series OSP-P ● Series OSP-E Belt drive* ● Series OSP-E Screw drive* ● ATEX-Versions 	
<p>Inversion Mounting</p> <ul style="list-style-type: none"> ● Series OSP-P ● Series OSP-E Belt drive* ● Series OSP-E Screw drive* 		<p>SENSOFLEX-Measuring system</p> <ul style="list-style-type: none"> ● Series SFI-plus 	
<p>Variable Stop VS</p> <ul style="list-style-type: none"> ● Series OSP-P with Linear Guide STL, KF, HD 		<p>Variable Stop VS</p> <ul style="list-style-type: none"> ● Series OSP-P with Linear Guide STL, KF, HD 	

Modular Components Overview – Rodless Cylinders Series OSP-P

Linear Drives	OSP-P10	OSP-P16	OSP-P25	OSP-P32	OSP-P40	OSP-P50	OSP-P63	OSP-P80
Theoretical force at 6bar [N]	47	120	295	483	754	1178	1870	3010
Effective force at 6bar [N]	32	78	250	420	640	1000	1550	2600
Velocity v [m/s]	> 0.005	> 0.005	> 0.005	> 0.005	> 0.005	> 0.005	> 0.005	> 0.005
Magnetic piston (three sides)	X	□	□	□	□	□	□	□
Lubrication - Prelubricated	□	□	□	□	□	□	□	□
Multiple air ports (4 x 90°)	X	□	□	□	□	□	□	□
Both Air Connections at End-face	X	○	○	○	○	○	○	○
Air Connection on the End-face	X	○	○	○	○	○	○	○
Cushioning	□	□	□	□	□	□	□	□
Cushioning length[mm]	2,50	11	17	20	27	30	32	39
Stroke length [mm] ▲	1 - 6000	1 - 6000	1 - 6000	1 - 6000	1 - 6000	1 - 6000	1 - 6000	1 - 6000
Pressure range pmax [bar]	8.0	8.0	8.0	8.0	8.0	8.0	8.0	8.0
Temperature range [°C] *	-10 – + 80	-10 – + 80	-10 – + 80	-10 – + 80	-10 – + 80	-10 – + 80	-10 – + 80	-10 – + 80
Viton / chemical resistance	○	○	○	○	○	○	○	○
Stainless steel parts	○	○	○	○	○	○	○	○
Clevis Mounting	○	○	○	○	○	○	○	○
Slow speed lubrication	○	○	○	○	○	○	○	○
Duplex Connection / Multiplex Connection	X	on request	○	○	○	○	on request	on request
Tandem piston	○	○	○	○	○	○	○	○
Basic Cylinder								
F [N]	20	120	300	450	750	1200	1650	2400
Mx [Nm]	0.2	0.45	1.5	3	6	10	12	24
My [Nm]	1	4	15	30	60	115	200	360
Mz [Nm]	0.3	0.5	3	5	8	15	24	48
Slideline								
F [N]	X	325	675	925	1500	2000	2500	2500
Mx [Nm]	X	6	14	29	50	77	120	120
My [Nm]	X	11	34	60	110	180	260	260
Mz [Nm]	X	11	34	60	110	180	260	260
Proline								
F [N]	X	542	857	1171	2074	3111	X	X
Mx [Nm]	X	8	16	29	57	111	X	X
My [Nm]	X	12	39	73	158	249	X	X
Mz [Nm]	X	12	39	73	158	249	X	X
Powerslide								
F [N]	X	1400	1400 - 3000	1400 - 3000	3000	3000 - 4000	X	X
Mx [Nm]	X	14	14 - 65	20 - 65	65 - 90	90 - 140	X	X
My [Nm]	X	45	63 - 175	70 - 175	175 - 250	250 - 350	X	X
Mz [Nm]	X	45	63 - 175	70 - 175	175 - 250	250 - 350	X	X
Starline								
F [N]	X	1000	3100	3100	4000-7500	4000-7500	X	X
Mx [Nm]	X	15	50	62	150	210	X	X
My [Nm]	X	30	110	160	400	580	X	X
Mz [Nm]	X	30	110	160	400	580	X	X
– variable Stop	X	○	○	○	○	○	X	X
KF Guide								
F [N]	X	1000	3100	3100	4000-7100	4000-7500	X	X
Mx [Nm]	X	12	35	44	119	170	X	X
My [Nm]	X	25	90	133	346	480	X	X
Mz [Nm]	X	25	90	133	346	480	X	X
– variable Stop	X	○	○	○	○	○	X	X

Linear Drives	OSP-P10	OSP-P16	OSP-P25	OSP-P32	OSP-P40	OSP-P50	OSP-P63	OSP-P80
HD Heavy Duty Guide								
F [N]	X	X	6000	6000	15000	18000	X	X
Mx [Nm]	X	X	260	285	800	1100	X	X
My [Nm]	X	X	320	475	1100	1400	X	X
Mz [Nm]	X	X	320	475	1100	1400	X	X
– variable Stop	X	X	○	○	○	○	X	X
– intermediate stop module	X	X	○	X	X	X	X	X
Active Brake								
Braking force at 6 bar (brake surface dry) [N]	X	X	350	590	900	1400	2170	4000
Slideline SL / Proline PL with Brakes								
Active Brake								
SL Braking force at 6 bar (brake surface dry) [N]	X	X	325	545	835	1200	X	X
PL Braking force at 6 bar (brake surface dry) [N]	X	X	on request	on request	on request	on request	X	X
Passive Brake Multibrake								
SL Braking force at 6 bar (brake surface dry) [N]	X	X	470	790	1200	1870	2900	2900
PL Braking force at 6 bar (brake surface dry) [N]	X	X	315	490	715	1100	–	–
Magnetic Switches								
Standard Version	○	○	○	○	○	○	○	○
T-Nut Version	○	○	○	○	○	○	○	○
ATEX Version for EX- Areas (Ex)	○	○	○	○	○	○	○	○
Displacement measuring systems								
SFI-plus incremental	X	X	○	○	○	○	○	○
Integrated valves 3/2 WV NO VOE	X	X	○	○	○	○	on request	on request
Mountings								
End Cap Mounting / Mid-Section Support	○	○	○	○	○	○	○	○
Inversion Mounting	X	○	○	○	○	○	○	○
Shock absorber for intermediate positioning	X	X	on request	on request	on request	on request	X	X
Adaptor Profile / T-Nut Profile	X	○	○	○	○	○	X	X
Special Cylinders								
Special Pneumactical Cushioning System	X	on request	on request	on request	on request	on request	X	X
Clean Room Cylinders to DIN EN ISO 14644-1	X	○	○	○	X	X	X	X
Long-Stroke Cylinders (max. stroke length 41 m)	X	X	X	X	X	○	○	○
ATEX Version for EX-Areas (Ex)	○	○	○	○	○	○	○	○
Bi-parting Version	X	X	X	X	○	X	X	X
High-Speed up to 30 m/s	X	on request	on request	on request	X	X	X	X

- = Standard version
- ▲ = longer strokes on request
- * = other temperature ranges on request
- = Option
- × = not applicable

For Electric Linear Drives, Series OSP-E, see catalogue P-A4P017E

Examples

CONTROL EXAMPLES FOR OSP-P

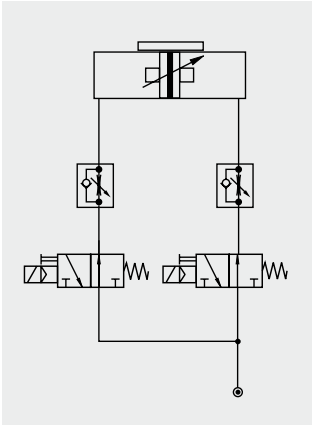

Circuit diagram for end of stroke application. Intermediate positioning is also possible.

The cylinder is controlled by two 3/2-way valves (normally open). The speed can be adjusted independently for both directions.

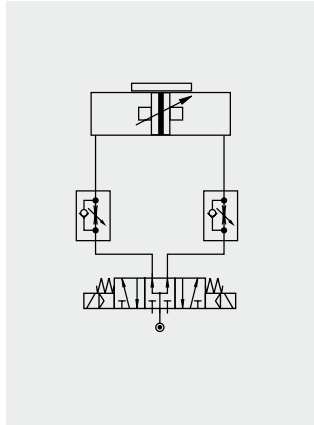

Circuit diagram for end of stroke application. Intermediate positioning is also possible.

The cylinder is controlled by a 5/3-way valve (middle position pressurized). The speed can be adjusted independently for both directions.

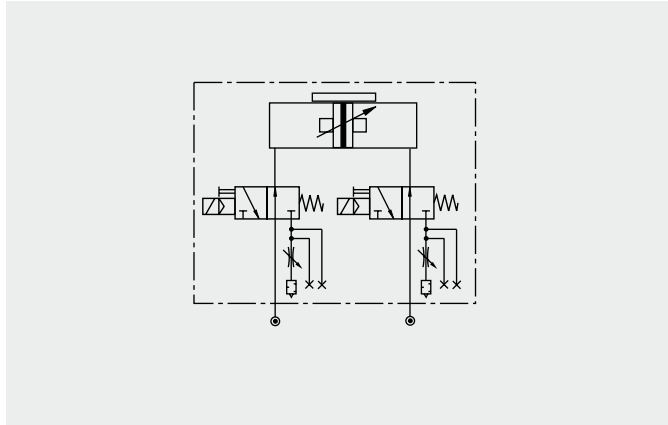

The optional integrated VOE Valves offer optimal control, and allow accurate

positioning of intermediate positions and the lowest possible speeds.

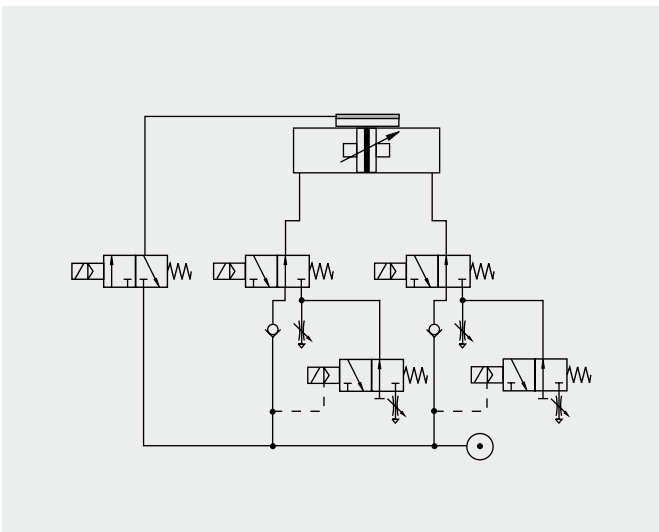

Fast/Slow speed cycle control with pneumatic brake for accurate positioning at high velocities. Additional 3/2-way valves with adjustable throttle valves at the exhaust of the standard directional control valves for two displacement

speeds in each direction of the piston's travel. The valve controlling the brake is activated after the slow speed cycle is activated

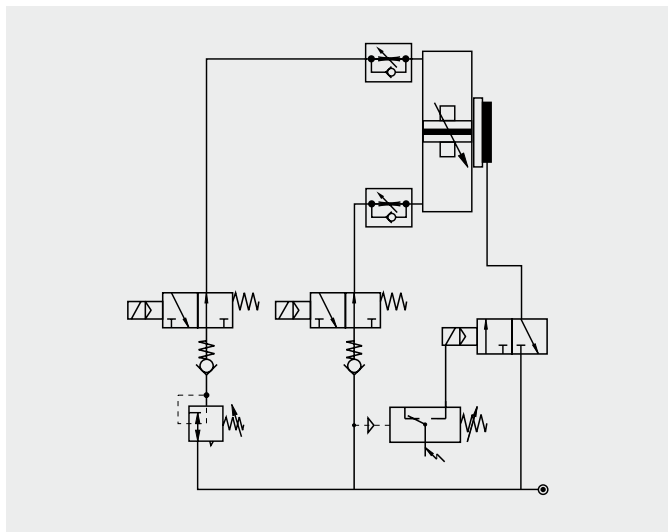

The combination of an OSP-cylinder with the passive MULTIBRAKE as shown here, allows accurate positioning and safety in case of loss of pneumatic air pressure.

OSP-P APPLICATION EXAMPLES

ORIGA SYSTEM PLUS – rodless linear drives offer maximum flexibility for any application.

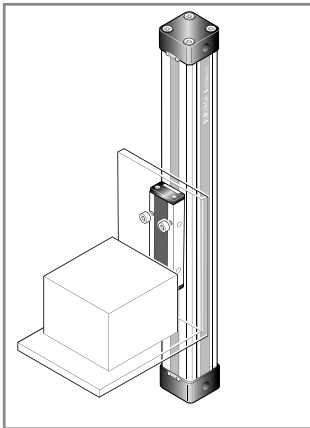

The high load capacity of the piston can cope with high bending moments without additional guides.

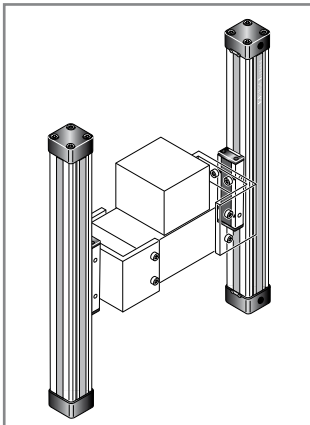
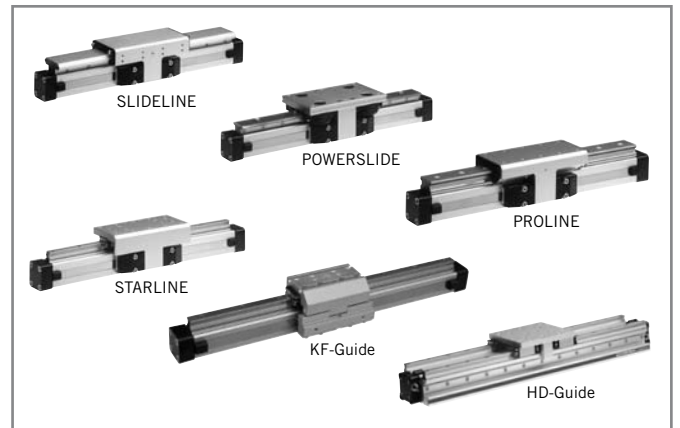

The mechanical design of the OSP-P allows synchronised movement of two cylinders.

Integrated guides offer optimal guidance for applications requiring high performance, easy assembly and maintenance free operation.

Optimal system performance by combining multi-axis cylinder combinations.

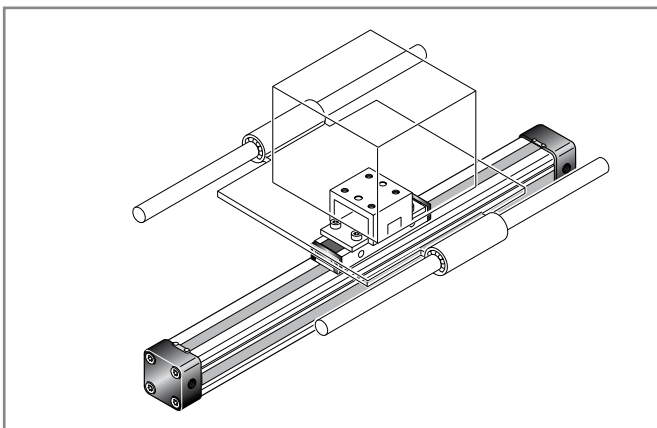

When using external guides, the clevis mounting is used to compensate for deviations in parallelism.

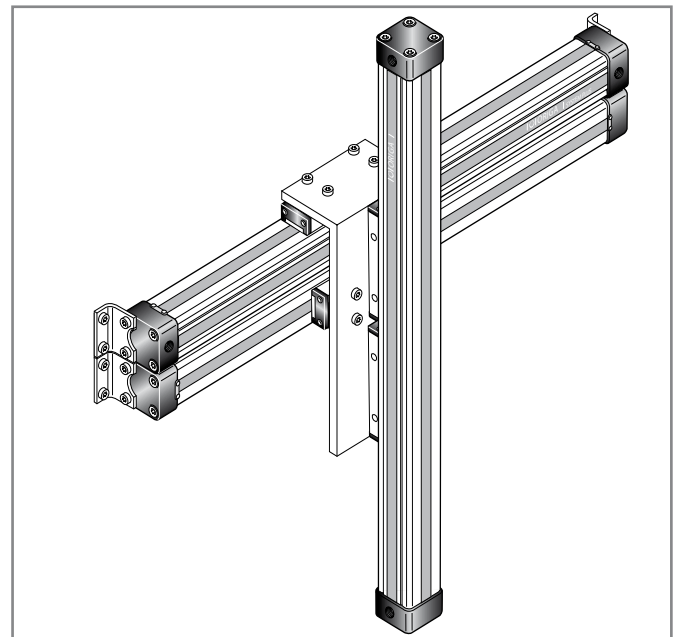

For further information and assembly instructions, please contact your local Parker Origa dealer.

Rodless Pneumatic Cylinders Series OSP-P

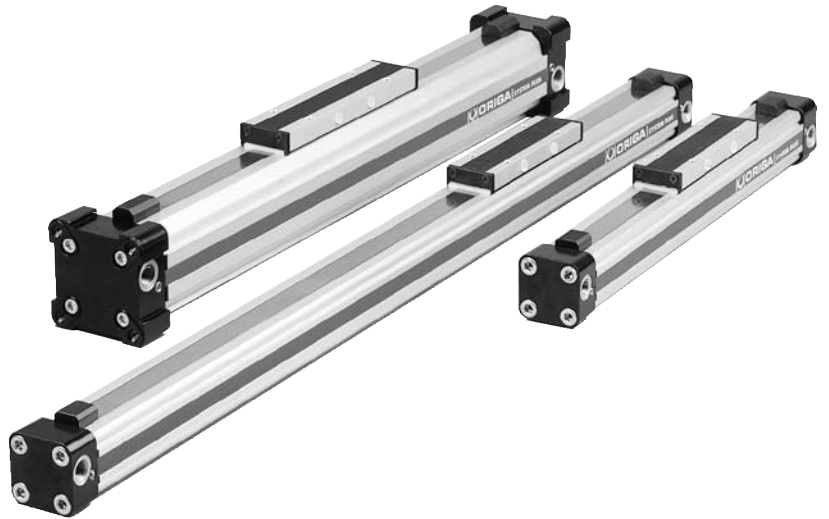

Contents

Description	Data Sheet No.	Page
Standard Cylinders		
Overview	P-1.10.001E	9-13
Technical Data	P-1.10.002E-1 to 3	15-17
Dimensions	P-1.10.002E-4 to 9	18-23
Order Instructions	P-1.10.002E-10	24
Long-Stroke Cylinders		
Technical Data	P-1.10.002E-11 to 12	25-26
Dimensions	P-1.10.002E-13 to 14	27-28
Order Instructions	P-1.10.002E-15	29
Clean Room Cylinders		
Technical Data	P-1.10.003E-1 to 2	31-32
Dimensions	P-1.10.003E-3	33
Order Instructions	P-1.10.003E-4	34
Cylinders ATEX-Version 		
Technical Data	P-1.10.020E-1	35
Dimensions	P-1.10.002E-4 to 9	16-21
Order Instructions	P-1.10.020E-2	36
Cylinders for synchronized bi-parting movements		
Technical Data	P-1.10.021E-1	37
Dimensions	P-1.10.021E-2	38
Order Instructions	P-1.10.021E-2	38

ORIGA SYSTEM PLUS

– INNOVATION FROM A PROVEN DESIGN

A completely new generation of linear drives which can be simply and neatly integrated into any machine layout.

A NEW MODULAR LINEAR DRIVE SYSTEM

With this second generation linear drive Parker Origa offers design engineers complete flexibility. The well known ORIGA cylinder has been further developed into a combined linear actuator, guidance and control package. It forms the basis for the new, versatile ORIGA SYSTEM PLUS linear drive system.

All additional functions are designed into modular system components which replace the previous series of cylinders.

MOUNTING RAILS ON 3 SIDES

Mounting rails on 3 sides of the cylinder enable modular components such as linear guides, brakes, valves, magnetic switches etc. to be fitted to the cylinder itself. This solves many installation problems, especially where space is limited.

The modular system concept forms an ideal basis for additional customer-specific functions.

Magnetic piston as standard - for contactless position sensing on three sides of the cylinder.

Corrosion resistant steel outer sealing band and robust wiper system on the carrier for use in aggressive environments.

Proven corrosion resistant steel inner sealing band for optimum sealing and extremely low friction.

Combined clamping for inner and outer sealing band with dust cover.

Stainless steel screws optional.

Low friction piston seals for optimized running characteristics

Optimized cylinder profile for maximum stiffness and minimum weight. Integral air passages enable both air connections to be positioned at one end, if desired.

End cap can be rotated to any one of the four positions (before or after delivery) so that the air connection can be in any desired position.

Install the OSP-P System to simplify design work! The files are compatible with all popular CAD systems and package hardware.

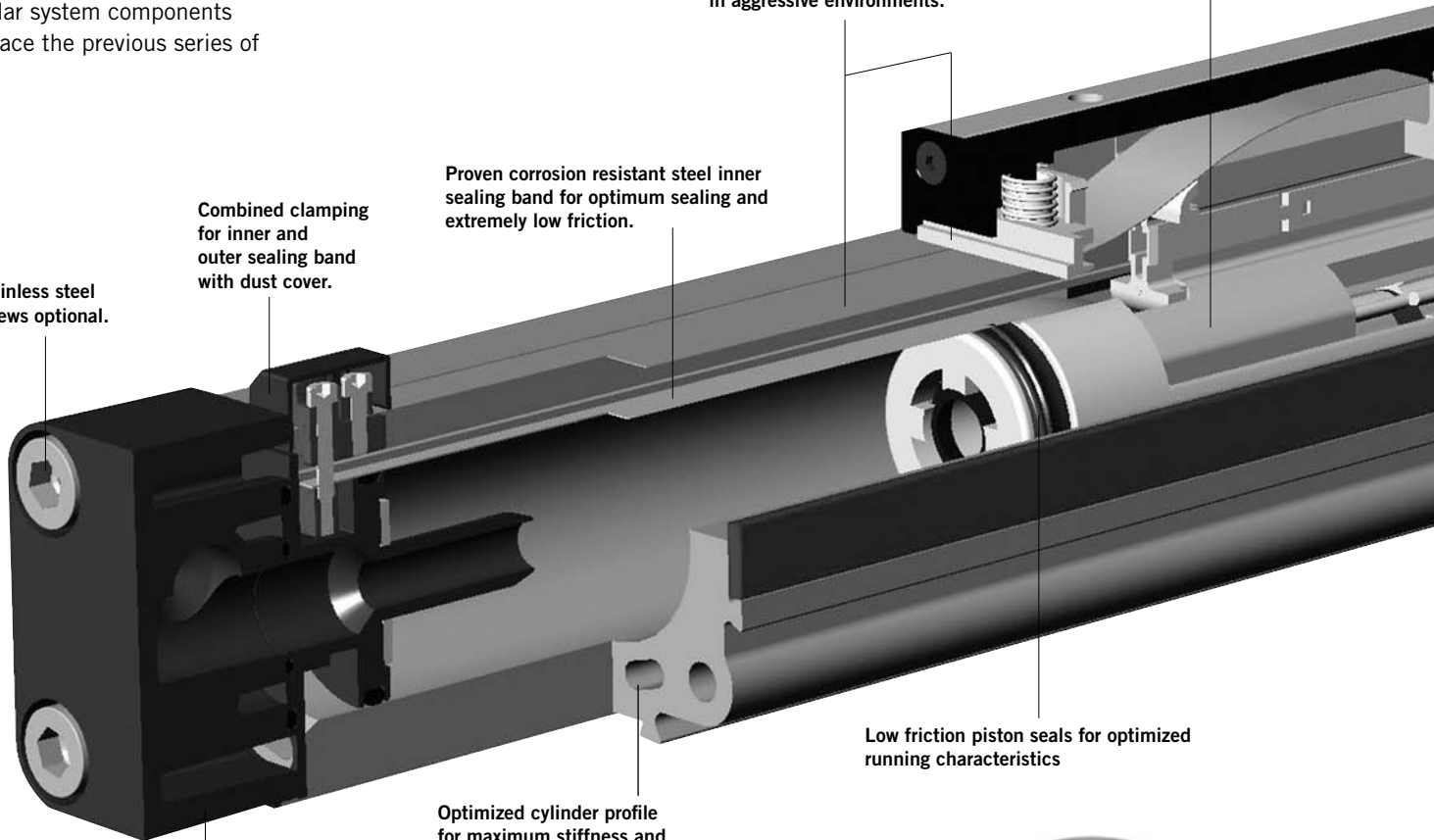

Clean Room Version
certified to DIN EN ISO 14644-1

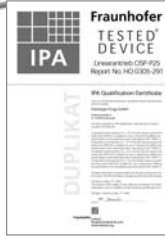

Rodless Cylinder
for synchronized bi-parting movements

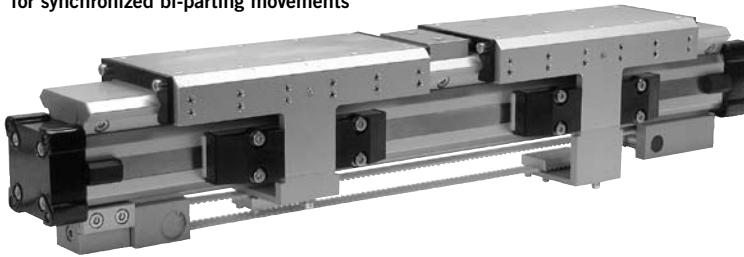

New low profile
piston/carrier design.

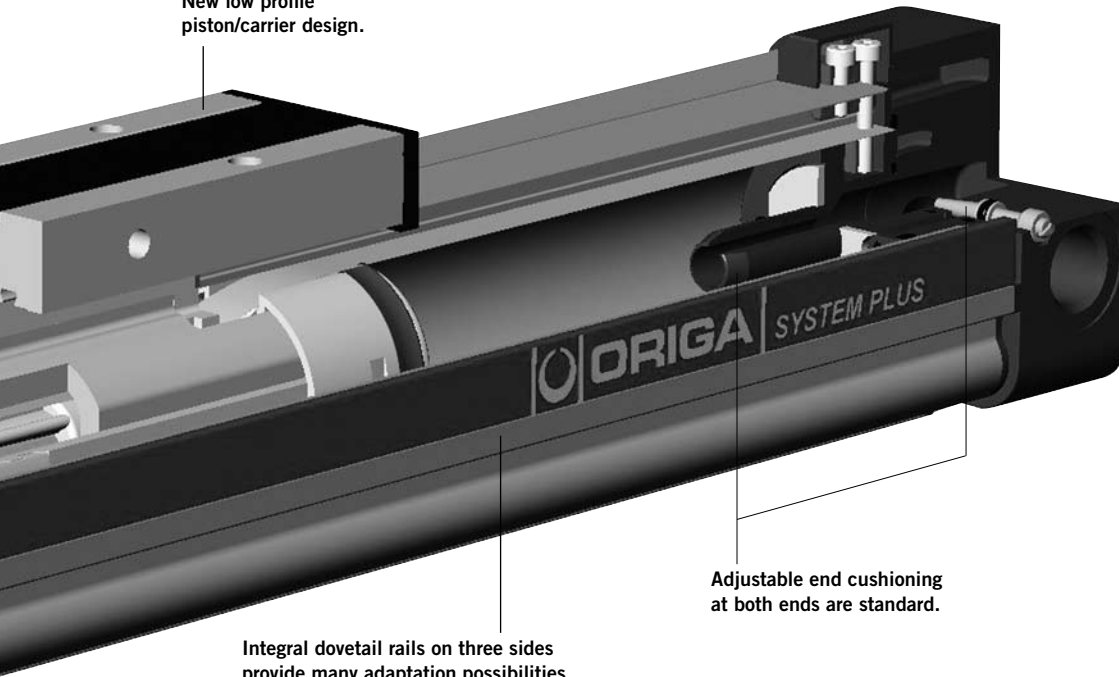

Adjustable end cushioning
at both ends are standard.

Integral dovetail rails on three sides
provide many adaptation possibilities
(linear guides, magnetic switches, etc.).

Modular system components
are simply clamped on.

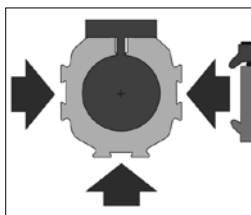

**INTEGRATED
VOE VALVES**
The complete compact
solution for optimal
cylinder control.

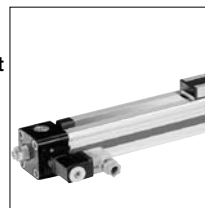

**SENSOFLEX
SFI-plus**
incremental
measuring system
with 0,1 (1,0) mm
resolution



SLIDELINE
Combination with
linear guides
provides for heavier
loads.



POWERSLIDE
Roller bearing
precision
guidance for
smooth travel
and high dynamic or
static loads.



PROLINE
The compact
aluminium roller
guide for high loads
and velocities.

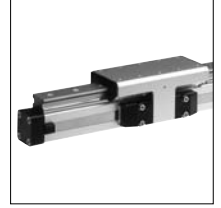

STARLINE
Recirculating ball
bearing guide for
very high loads and
precision



KF GUIDE
Recirculating ball
bearing guide – the
mounting dimen-
sions correspond
to FESTO Type:
DGPL-KF



**HEAVY DUTY
GUIDE HD**
for heavy duty
applications.

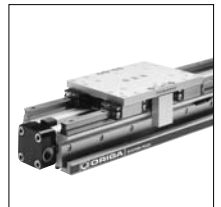

**VARIABLE STOP
VS**
The variable stop
provides simple
stroke limitation.

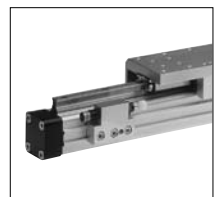

Passive
pneumatic brake
reacts automatically
to pressure failure.



Active pneumatic
brake for secure,
positive stopping at
any position.

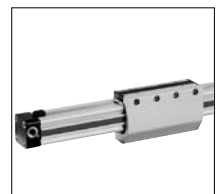

OPTIONS AND ACCESSORIES FOR SYSTEM VERSATILITY

SERIES OSP-P

STANDARD VERSIONS OSP-P10 to P80

Data Sheet P-1.10.002E-1, -2, -3
Standard carrier with integral guidance. End cap can be rotated 4 x 90° to position air connection on any side.
Magnetic piston as standard.
Dovetail profile for mounting of accessories and the cylinder itself.

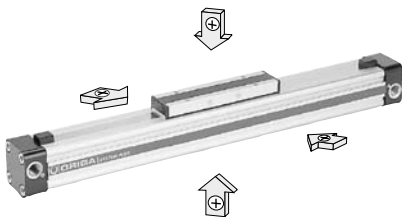

LONG-STROKE VERSION
Data Sheet P-1.10.002E- 11
For extremely long strokes up to max. 41m



BASIC CYLINDER OPTIONS

CLEAN ROOM CYLINDERS
Data Sheet P-1.10.003E

For use in clean room applications, certified with the IPA-Certificate (to DIN EN ISO 14644-1).
The special design of the linear drive enables all emissions to be led away.



ATEX-Version
Data Sheet P-1.10.020E
For use in Ex-Areas



STAINLESS VERSION
For use in constantly damp or wet environments. All screws are A2 quality stainless steel (material no.1.4301 / 1.4303)



SLOW SPEED OPTIONS
Specially formulated grease lubrication facilitates slow, smooth and uniform piston travel in the speed range from 0.005 to 0.2 m/s. Minimum achievable speeds are dependent on several factors. Please consult our technical department. Slow speed lubrication in combination with Viton® on demand. Oil free operation preferred.



VITON® VERSION
For use in an environment with high temperatures or in chemically aggressive areas.
All seals are made of Viton®.
Sealing bands: Stainless steel



END-FACE AIR CONNECTION
Data Sheet P-1.10.002E-6
To solve special installation problems.



BOTH AIR CONNECTIONS AT ONE END
Data Sheet P-1.10.002E-7
For simplified tubing connections and space saving.



INTEGRATED VOE VALVES
Data Sheet P-1.10.002E-8
The complete compact solution for optimal cylinder control.



DUPLEX CONNECTION
Data Sheet P-1.45.011E
The duplex connection combines two OSP-P cylinders of the same size into a compact unit with high performance.

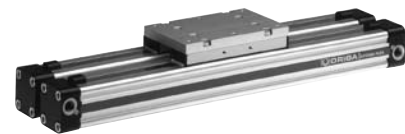

MULTIPLEX CONNECTION
Data Sheet P-1.45.012E
The multiplex connection combines two or more OSP-P cylinders of the same size into one unit. The orientation of the carriers can be freely selected.



ACCESSORIES

MAGNETIC SWITCHES

TYPE RS, ES, RST, EST

Data Sheet 1.45.100E, 1.45.104E,
1.45.105E

For electrical sensing of end and
intermediate piston positions, also in
EX-Areas.



CLEVIS MOUNTING

Data Sheet 1.45.002E

Carrier with tolerance and parallelism
compensation for driving loads
supported by external linear guides.

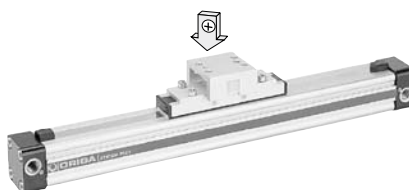

END CAP MOUNTING

Data Sheet 1.45.003E

For end-mounting of the cylinder.



MID-SECTION SUPPORT

Data Sheet 1.45.004E

For supporting long cylinders or
mounting the cylinder by its dovetail
rails.

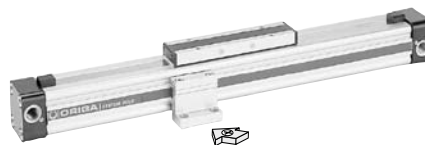

INVERSION MOUNTING

Data Sheet 1.45.006E

The inversion mounting transfers the
driving force to the opposite side, e. g.
for dirty environments.

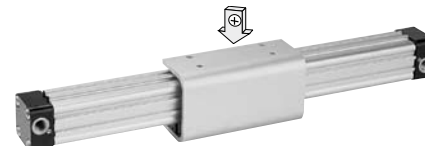

A3P101E00HAA00X

Characteristics		Pressures quoted as gauge pressure					
Characteristics	Symbol	Unit	Description				
General Features							
Type			Rodless cylinder				
Series			OSP-P				
System			Double-acting, with cushioning, position sensing capability				
Mounting			See drawings				
Air Connection			Threaded				
Ambient temperature range	T _{min} T _{max}	°C °C	-10 +80	Other temperature ranges on request			
Weight (mass)		kg	See table below				
Installation			In any position				
Medium			Filtered, unlubricated compressed air (other media on request)				
Lubrication			Permanent grease lubrication (additional oil mist lubrication not required) Option: special slow speed grease				
Material	Cylinder Profile		Anodized aluminium				
	Carrier (piston)		Anodized aluminium				
	End caps		Aluminium, lacquered / Plastic (P10)				
	Sealing bands		Corrosion resistant steel				
	Seals		NBR (Option: Viton®)				
	Screws		Galvanized steel Option: stainless steel				
	Dust covers, wipers		Plastic				
Max. operating pressure	p _{max}	bar	8				
Weight (mass) kg							
Cylinder series (Basic cylinder)	At 0 mm stroke		Weight (Mass) kg per 100 mm stroke				
OSP-P10	0.087		0.052				
OSP-P16	0.22		0.1				
OSP-P25	0.65		0.197				
OSP-P32	1.44		0.354				
OSP-P40	1.95		0.415				
OSP-P50	3.53		0.566				
OSP-P63	6.41		0.925				
OSP-P80	12.46		1.262				
Size Comparison							
P10	P16	P25	P32	P40	P50	P63	P80
For linear guides see 1.40.001E to 006E							
For magnetic switches see 1.45.100E, 1.45.104E, 1.45.105E							
For mountings and accessories see 1.45.001E to 009E							

Rodless Pneumatic Cylinder

∅ 10-80 mm



Series OSP-P..

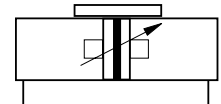

Standard Versions:

- Double-acting with adjustable end cushioning
- With magnetic piston for position sensing

Long-Stroke Cylinders for stroke lengths up to 41 m

(see data sheet P-1.10.002E-11)

Special Versions:

- with special pneumatic cushioning system (on request)
- Clean room cylinders (see data sheet P-1.10.003E)
- ATEX-Version (Ex) (see data sheet P-1.10.020E)
- Stainless steel screws
- Slow speed lubrication
- Viton® seals
- Both air connections on one end
- Air connection on the end-face
- Integrated Valves



- End cap can be rotated 4 x 90° to position air connection as desired
- Free choice of stroke length up to 6000 mm, Long-Stroke version (∅50-80mm) for stroke lengths up to 41 m

Loads, Forces and Moments

Choice of cylinder is decided by:

- Permissible loads, forces and moments
- Performance of the pneumatic end cushions. The main factors here are the mass to be cushioned and the piston speed at start of cushioning (unless external cushioning is used, e. g. hydraulic shock absorbers).

The adjacent table shows the maximum values for light, shock-free operation, which must not be exceeded even in dynamic operation. **Load and moment data are based on speeds $v \leq 0.5$ m/s.**

When working out the action force required, it is essential to take into account the friction forces generated by the specific application or load.

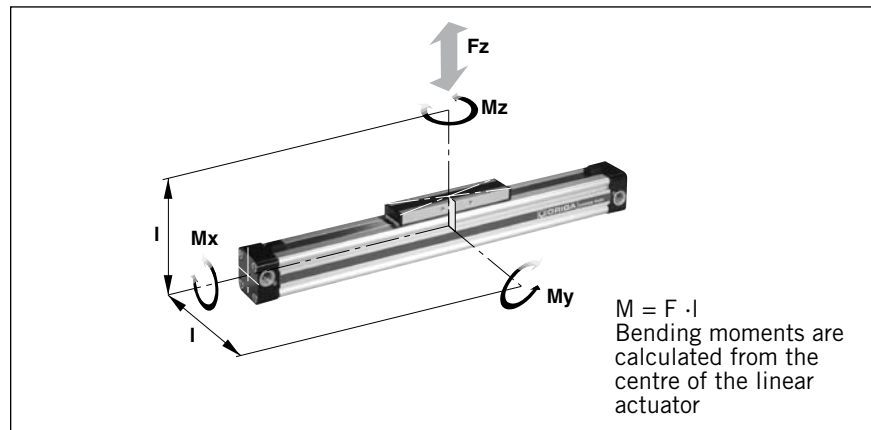

Cylinder-Series [mm Ø]	Theoretical Action Force at 6 bar [N]	effektive Action Force F_A at 6 bar [N]	max. Moments			max. Load F [N]	Cushion Length [mm]
			Mx [Nm]	My [Nm]	Mz [Nm]		
OSP-P10	47	32	0.2	1	0.3	20	2.5 *
OSP-P16	120	78	0.45	4	0.5	120	11
OSP-P25	295	250	1.5	15	3	300	17
OSP-P32	483	420	3	30	5	450	20
OSP-P40	754	640	6	60	8	750	27
OSP-P50	1178	1000	10	115	15	1200	30
OSP-P63	1870	1550	12	200	24	1650	32
OSP-P80	3016	2600	24	360	48	2400	39

* A rubber element (non-adjustable) is used for end cushioning. To deform the rubber element enough to reach the absolute end position would require a Δp of 4 bar!

Cushioning Diagram

Work out your expected moving mass and read off the maximum permissible speed at start of cushioning. Alternatively, take your desired speed and expected mass and find the cylinder size required.

Please note that piston speed at start of cushioning is typically ca. 50 % higher than the average speed, and that it is this higher speed which determines the choice of cylinder. If these maximum permissible values are exceeded, additional shock absorbers must be used.

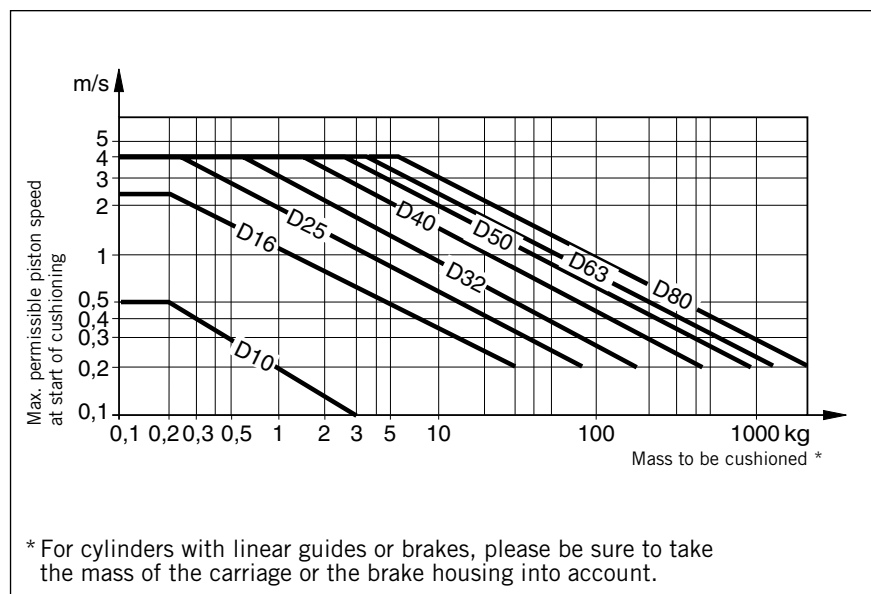

If the permitted limit values are exceeded, either additional shock absorbers should be fitted in the area of the centre of gravity or you can consult us about our special cushioning system
– we shall be happy to advise you on your specific application.

Mid-Section Supports

To avoid excessive bending and oscillation of the cylinder, mid-section supports are required dependent on specified stroke lengths and applied loads. The diagrams show the maximum possible support spacings depending on the load.

Bending up to max. 0.5 mm is permissible between supports. The mid-section supports are clamped on to the dovetail profile of the cylinder tube. They are also able to take the axial forces.

For types and dimensions see 1.45.004E.

Permissible Support Spacings: OSP - P10 - P32

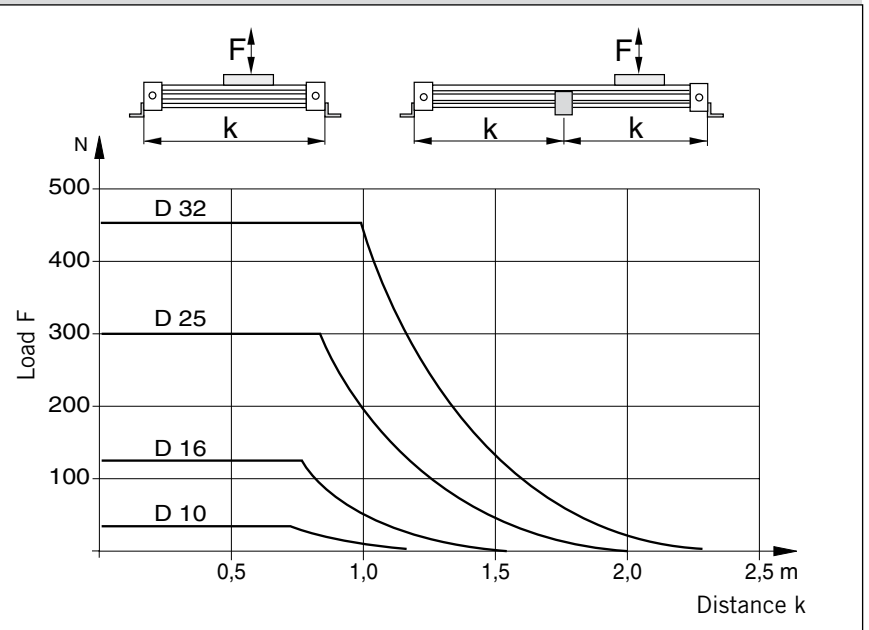

Permissible Support Spacings: OSP - P40 - P80

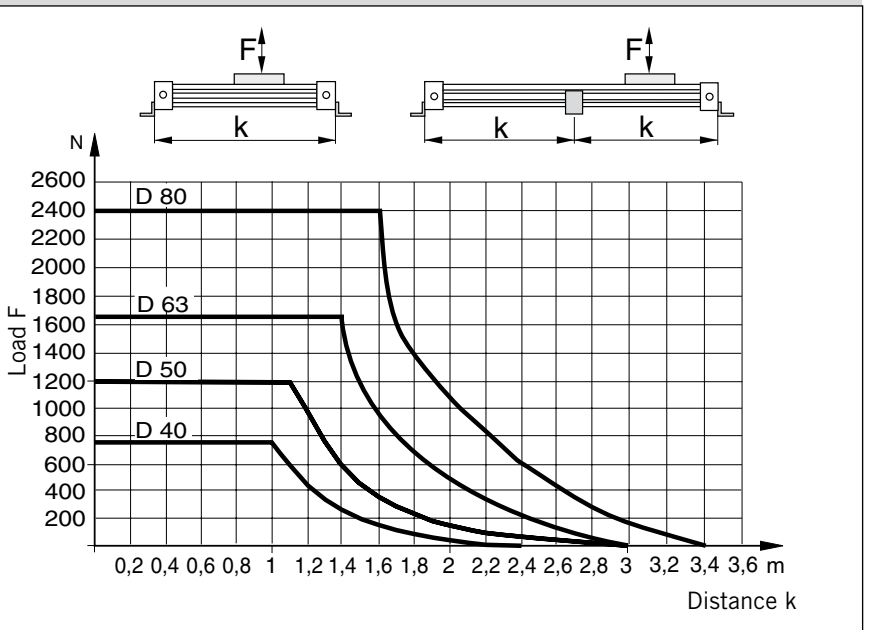

Cylinder Stroke and Dead Length A

- Free choice of stroke length up to 6000 mm in 1 mm steps.
- Longer strokes on request

Dimensions of Basic Cylinder OSP-P10

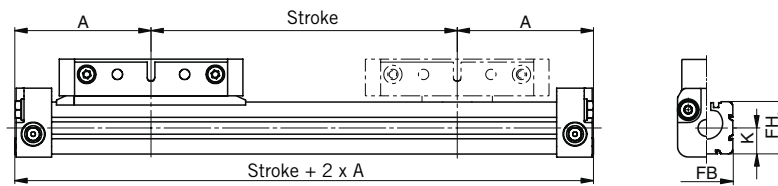

Tandem Cylinder

Two pistons are fitted: dimension "Z" is optional. (Please note minimum distance "Zmin").

- Free choice of stroke length up to 6000 mm in 1 mm steps
- Longer strokes on request
- **Stroke length to order is stroke + dimension "Z"**

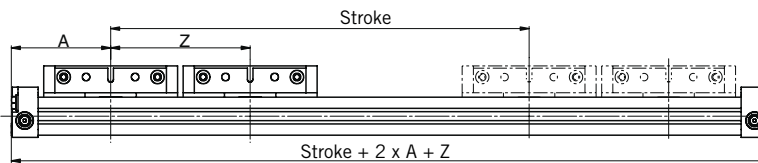

Please note:

To avoid multiple actuation of magnetic switches, the second piston is not equipped with magnets.

End Cap/Air Connection Series OSP-P10

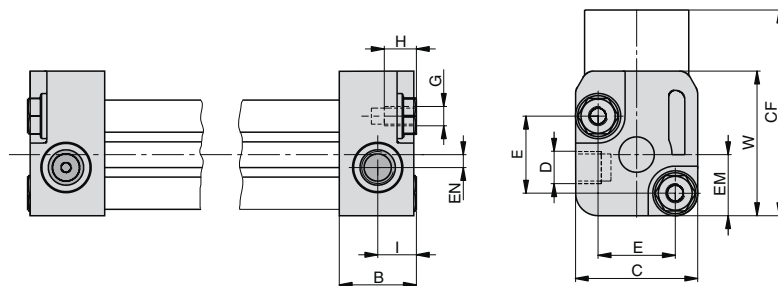

Carrier Series OSP-P10

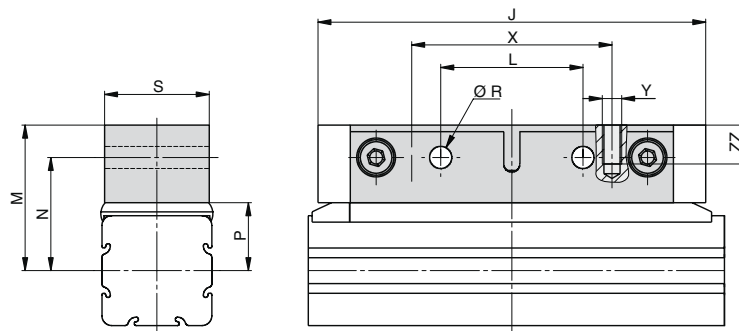

Dimension Table (mm)

Cylinder Series	A	B	C	D	E	G	H	I	J	K	L	M	N	P	R	S	W	X	Y	Z _{min}	CF	EM	EN	FB	FH	ZZ
OSP-P10	44.5	12	19	M5	12	M3	5	6	60	8.5	22	22.5	17.5	10.5	3.4	16	22.5	31	M3	64	32	9.5	2	17	17	6

Dimensions of Basic Cylinder OSP - P16-P80

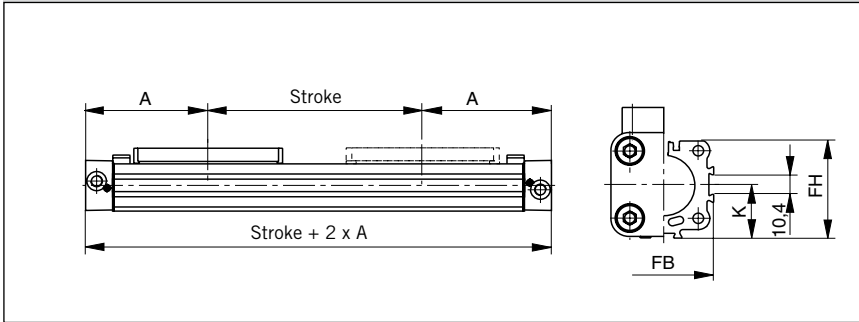

Cylinder Stroke and Dead Length A

- Free choice of stroke length up to 6000 mm in 1 mm steps.
- Longer strokes on request.

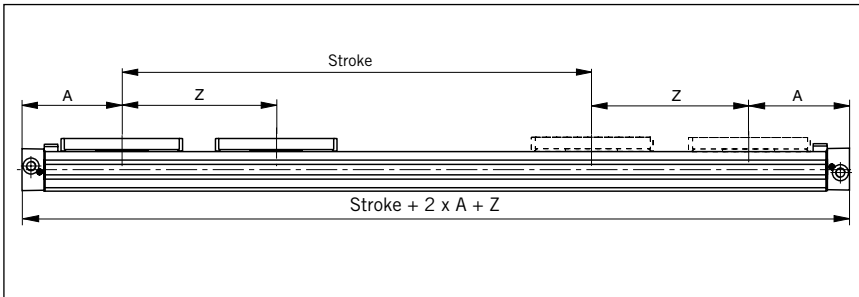

Tandem Cylinder

Two pistons are fitted: dimension "Z" is optional. (Please note minimum distance "Zmin").

- Free choice of stroke length up to 6000 mm in 1 mm steps
- Longer strokes on request
- **Stroke length to order is stroke + dimension "Z"**

End Cap/Air Connection can be rotated 4 x 90° Series OSP-P16 to P32

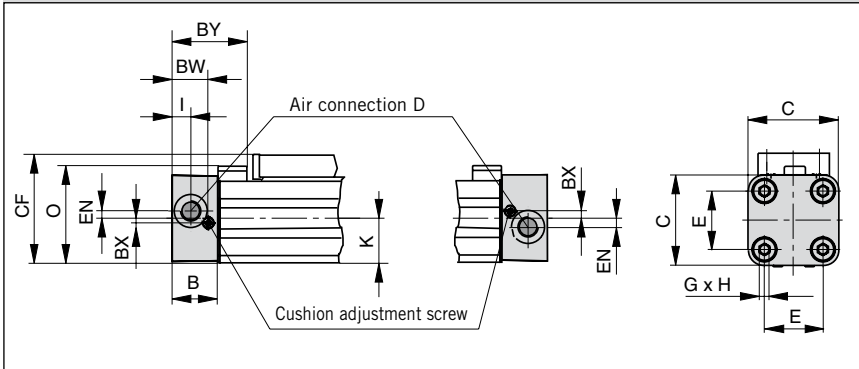

Please note:

To avoid multiple actuation of magnetic switches, the second piston is not equipped with magnets.

End Cap/Air Connection can be rotated 4 x 90° Series OSP-P40 to P80

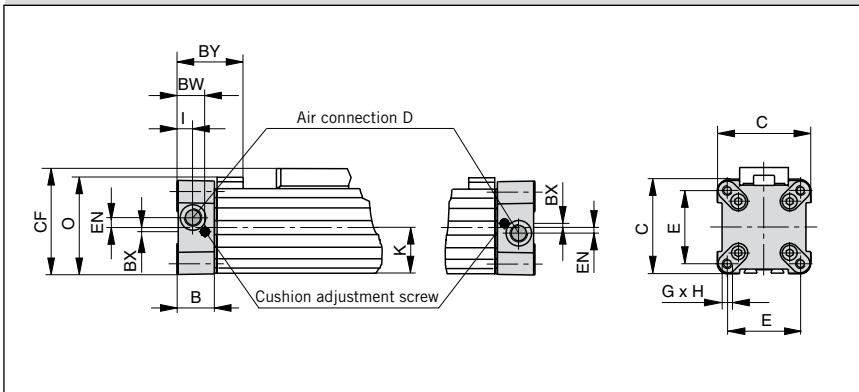

Carrier Series OSP-P16 to P80

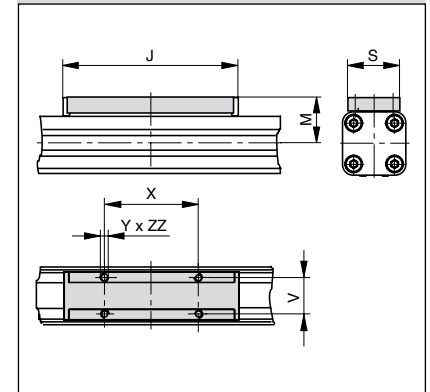

Dimension Table (mm)

Cylinder Series	A	B	C	D	E	G	H	I	J	K	M	O	S	V	X	Y	Z min	BW	BX	BY	CF	EN	FB	FH	ZZ
OSP-P16	65	14	30	M5	18	M3	9	5.5	69	15	23	33.2	22	16.5	36	M4	81	10.8	1.8	28.4	38	3	30	27.2	7
OSP-P25	100	22	41	G1/8	27	M5	15	9	117	21.5	31	47	33	25	65	M5	128	17.5	2.2	40	52.5	3.6	40	39.5	8
OSP-P32	125	25.5	52	G1/4	36	M6	15	11.5	152	28.5	38	59	36	27	90	M6	170	20.5	2.5	44	66.5	5.5	52	51.7	10
OSP-P40	150	28	69	G1/4	54	M6	15	12	152	34	44	72	36	27	90	M6	212	21	3	54	78.5	7.5	62	63	10
OSP-P50	175	33	87	G1/4	70	M6	15	14.5	200	43	49	86	36	27	110	M6	251	27	-	59	92.5	11	76	77	10
OSP-P63	215	38	106	G3/8	78	M8	21	14.5	256	54	63	107	50	34	140	M8	313	30	-	64	117	12	96	96	16
OSP-P80	260	47	132	G1/2	96	M10	25	22	348	67	80	133	52	36	190	M10	384	37.5	-	73	147	16.5	122	122	20

Air Connection on the End-face

In some situations it is necessary or desirable to fit a special end cap with the air connection on the end-face instead of the standard end cap with the air connection on the side. The special end cap can also be rotated $4 \times 90^\circ$ to locate the cushion adjustment screw as desired. Supplied in pairs.



Series OSP-P16 to P32

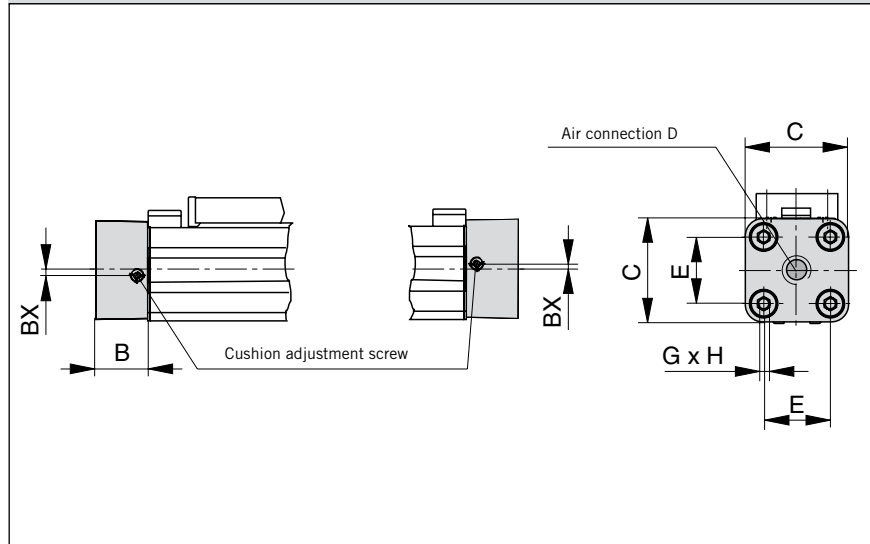

Series OSP-P40 to P80

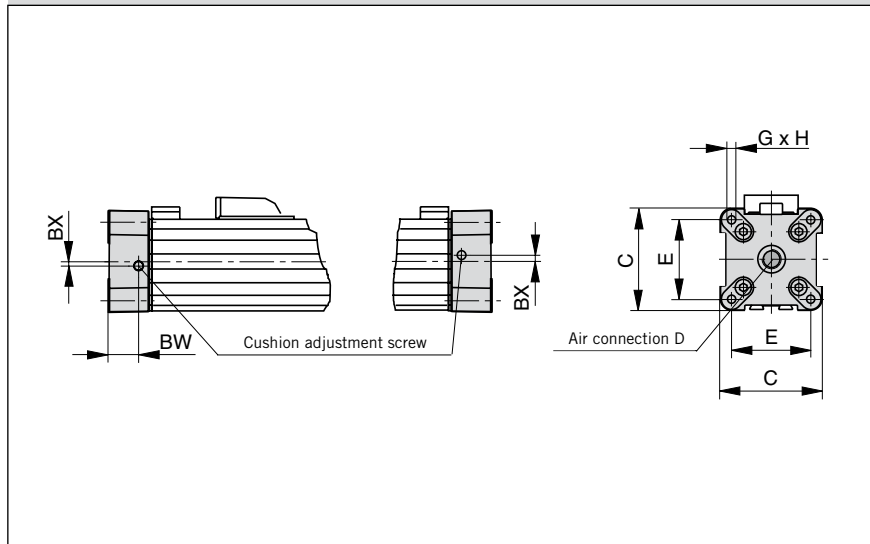

Dimension Table (mm)

Cylinder Series	B	C	D	E	G	H	BX	BW
OSP-P16	14	30	M5	18	M3	9	1.8	10.8
OSP-P25	22	41	G1/8	27	M5	15	2.2	17.5
OSP-P32	25.5	52	G1/4	36	M6	15	2.5	20.5
OSP-P40	28	69	G1/4	54	M6	15	3	21
OSP-P50	33	87	G1/4	70	M6	15	–	27
OSP-P63	38	106	G3/8	78	M8	21	–	30
OSP-P80	47	132	G1/2	96	M10	25	–	37.5

Series OSP-P16

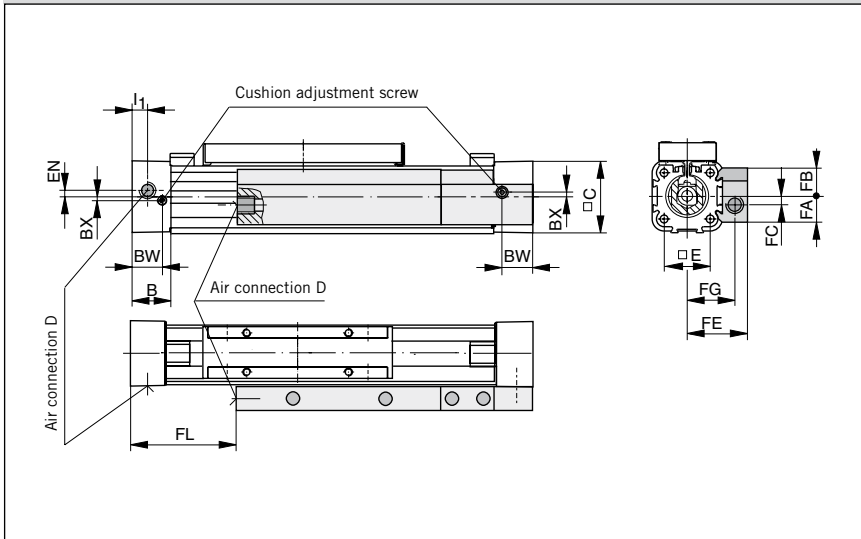

Both Air Connections at One End

A special end cap with both air connections on one side is available for situations where shortage of space, simplicity of installation or the nature of the process make it desirable. Air supply to the other end is via internal air passages (OSP-P25 to P80) or via a hollow aluminium profile fitted externally (OSP-P16).

In this case the end caps cannot be rotated.



Series OSP-P25

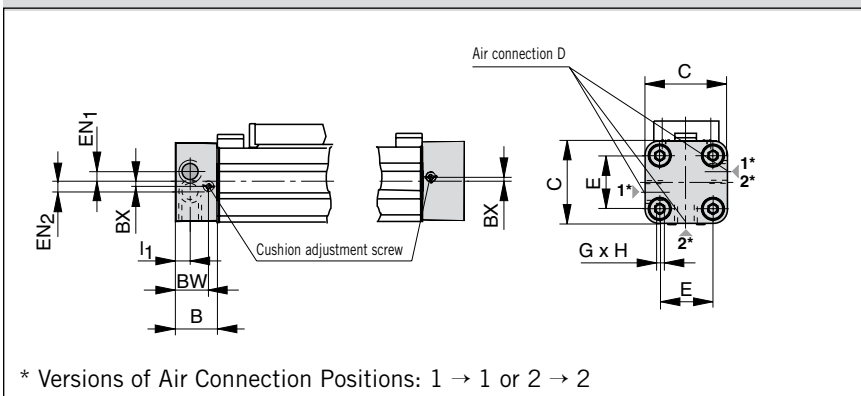

* Versions of Air Connection Positions: 1 → 1 or 2 → 2

Please note:
When combining the OSP-P16 single end porting with inversion mountings, RS magnetic switches can only be mounted directly opposite to the external air-supply profile.

Series OSP-P32 to P80

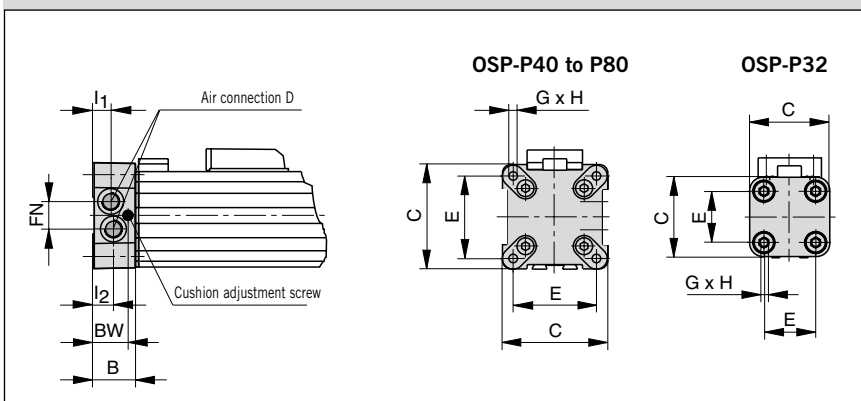

Dimension Table (mm)

Cylinder Series	B	C	D	E	G	H	I ₁	I ₂	BX	BW	EN	EN ₁	EN ₂	FA	FB	FC	FE	FG	FL	FN
OSP-P16	14	30	M5	18	M3	9	5.5	-	1.8	10.8	3	-	-	12.6	12.6	4	27	21	36	-
OSP-P25	22	41	G1/8	27	M5	15	9	-	2.2	17.5	-	3.6	3.9	-	-	-	-	-	-	-
OSP-P32	25.5	52	G1/8	36	M6	15	12.2	10.5	-	20.5	-	-	-	-	-	-	-	-	-	15.2
OSP-P40	28	69	G1/8	54	M6	15	12	12	-	21	-	-	-	-	-	-	-	-	-	17
OSP-P50	33	87	G1/4	70	M6	15	14.5	14.5	-	27	-	-	-	-	-	-	-	-	-	22
OSP-P63	38	106	G3/8	78	M8	21	16.5	13.5	-	30	-	-	-	-	-	-	-	-	-	25
OSP-P80	47	132	G1/2	96	M10	25	22	17	-	37.5	-	-	-	-	-	-	-	-	-	34.5

Integrated 3/2 Way Valves VOE

For optimal control of the OSP-P cylinder, 3/2 way valves integrated into the cylinder's end caps can be used as a compact and complete solution. They allow for easy positioning of the cylinder, smooth operation at the lowest speeds and fast response, making them ideally suited for the direct control of production and automation processes.

Characteristics:

- Complete compact solution
- Various connection possibilities:
Free choice of air connection with rotating end caps with VOE valves, Air connection can be rotated 4 x 90°, Solenoid can be rotated 4 x 90°, Pilot valve can be rotated 180°
- High piston velocities can be achieved with max. 3 exhaust ports
- Minimal installation requirements
- Requires just one air connection per valve
- Optimal control of the OSP-P cylinder
- Excellent positioning characteristics
- Integrated operation indicator
- Integrated exhaust throttle valve
- Manual override - indexed
- Adjustable end cushioning
- Easily retrofitted – please note the increase in the overall length of the cylinder!

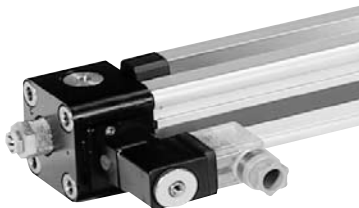

Integrated 3/2 Way Valves VOE Series OSP-P25, P32, P40 and P50



Characteristics 3/2 Way Valves VOE

Characteristics	3/2 Way Valves with spring return			
Pneumatic diagram				
Type	VOE-25	VOE-32	VOE-40	VOE-50
Actuation	electrical			
Basic position	P → A open, R closed			
Type	Poppet valve, non overlapping			
Mounting	integrated in end cap			
Installation	in any position			
Port size	G 1/8	G 1/4	G 3/8	G 3/8
Temperature	-10°C to +50°C *			
Operating pressure	2-8 bar			
Nominal voltage	24 V DC / 230 V AC, 50 Hz			
Power consumption	2,5 W / 6 VA			
Duty cycle	100%			
Electrical Protection	IP 65 DIN 40050			

* other temperature ranges on request

Dimensions VOE Valves OSP-P25 and P32

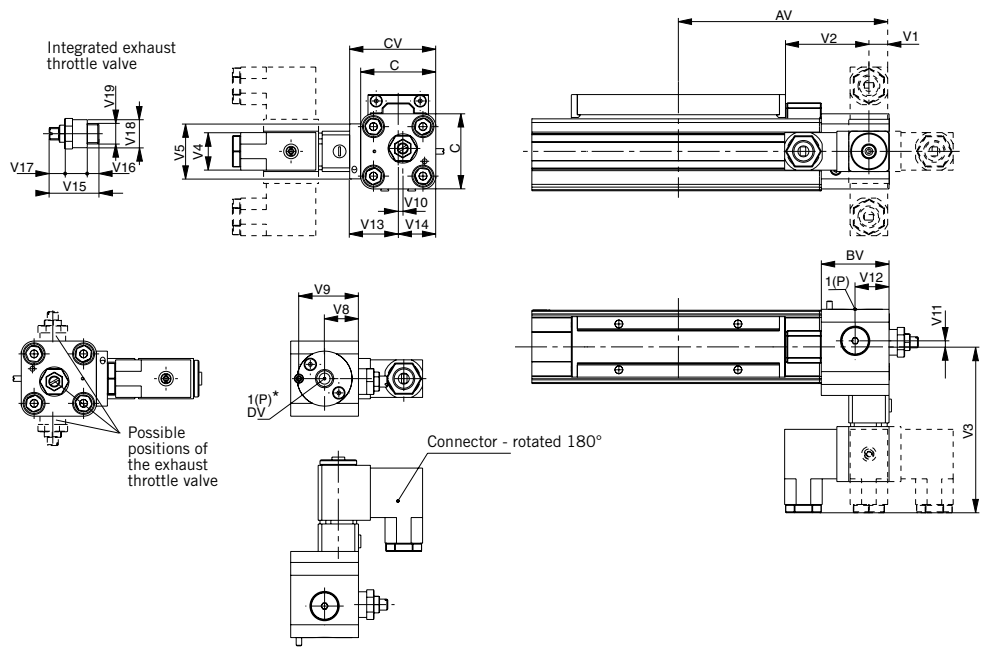

* End cap can be rotated 4x90°

Dimension Table (mm)

Cylinder Series	AV	BV	C	CV	DV	V1	V2	V3	V4	V5	V8	V9	V10	V11	V12	V13	V14	V15	V16	V17	V18	V19
OSP-P25	115	37	41	47	G1/8	11	46	90.5	22	30	18.5	32.5	2.5	3.3	18.5	26.5	20.5	24	5	4	14	G1/8
OSP-P32	139	39.5	52	58	G1/4	20.5	46	96	22	32	20.5	34.7	6	5	20.5	32	26	32	7.5	6	18	G1/4

Dimensions VOE Valves OSP-P40 and P50

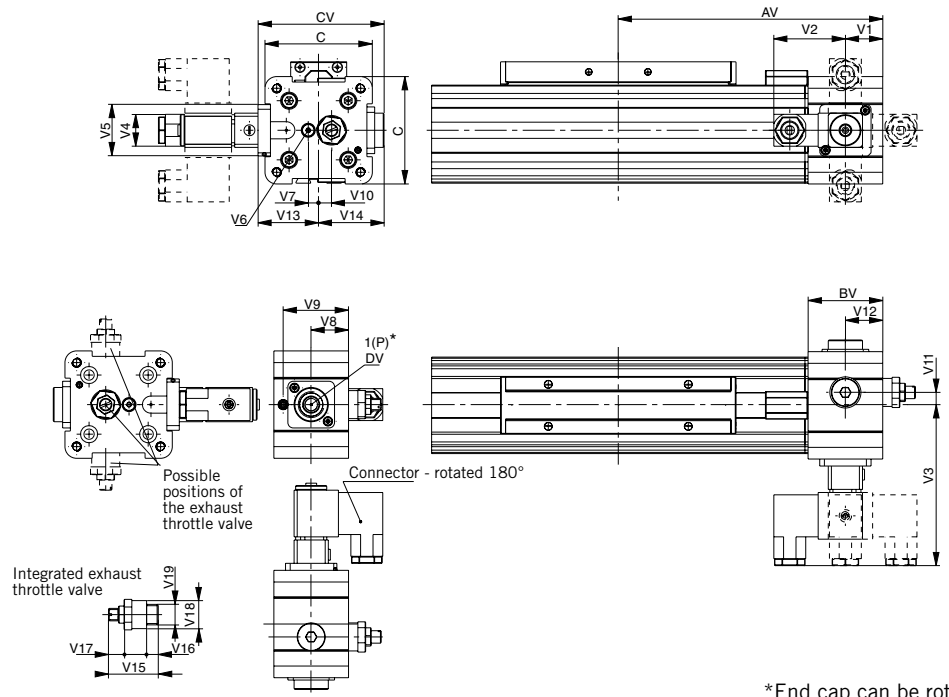

*End cap can be rotated 4x90°

Dimension Table (mm)

Cylinder Series	AV	BV	C	CV	DV	V1	V2	V3	V4	V5	V6	V7	V8	V9	V10	V11	V12	V13	V14	V15	V16	V17	V18	V19
OSP-P40	170	48	69	81	G3/8	24	46	103	22	33	M5	6.7	24	42	8.3	8.3	24	39	42	32	7.5	6	18	G1/4
OSP-P50	190	48	87	82	G3/8	24	46	102	22	33	M5	4.5	24	42	12.2	12.2	24	38	44	32	7.5	6	18	G1/4

Order Instructions – Basic Cylinder

Basic Cylinder

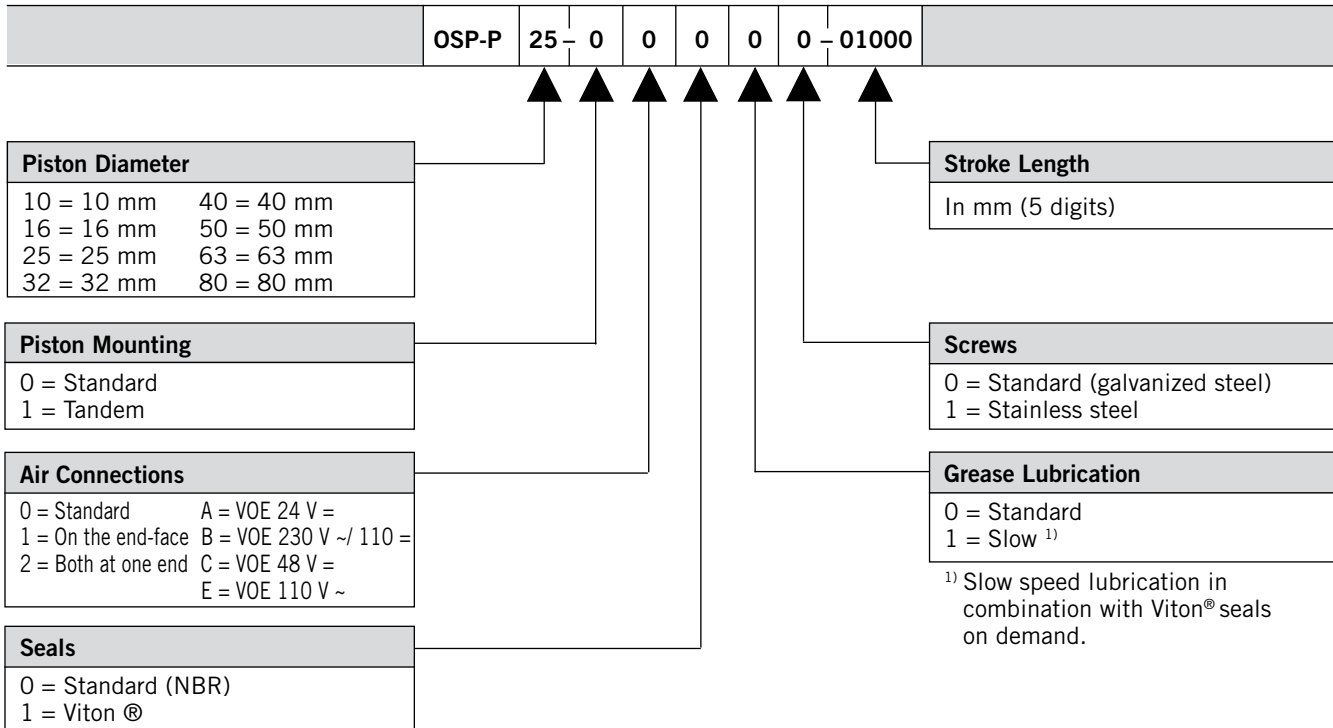

Accessories - please order separately

Description	Further information see Data Sheet No.
Clevis Mounting	1.45.002E
End Cap Mountings	1.45.003E
Mid-Section Support	1.45.004E
Inversion Mounting	1.45.006E
Adaptor Profile	1.45.007E
T-Slot Profile	1.45.008E
Adaptor Profile	1.45.009E
Duplex Connection	1.45.011E
Multiplex Connection	1.45.012E
Magnetic Switches	1.45.100E, 1.45.104E, 1.45.105E
Cable Cover	1.45.102E

P-A1P755E001AH00X

The right to introduce technical modifications is reserved

Characteristics		Pressures quoted as gauge pressure		
Characteristics	Symbol	Unit	Description	
General Features				
Type			Rodless cylinder	
Series			OSP-P	
System			Double-acting, with cushioning, position sensing capability	
Mounting			See drawings	
Air Connection			Threaded	
Ambient temperature range	T_{min} T_{max}	°C °C	+10 +40	Other temperature ranges on request
Weight (mass)		kg	See table below	
Installation			vertical, horizontal (piston at top or at bottom)	
Medium			Filtered, unlubricated compressed air (other media on request)	
Lubrication			Permanent grease lubrication (additional oil mist lubrication not required) Option: special slow speed grease	
Material	Cylinder Profile		Anodized aluminium	
	Carrier (piston)		Anodized aluminium	
	End caps		Anodized aluminium	
	Sealing bands		Corrosion resistant steel	
	Seals		NBR (Option: Viton®)	
	Screws		Galvanized steel Option: stainless steel	
	Dust covers, wipers		Plastic	
Max. operating pressure	p_{max}	bar	8	
Max. speed	v	m/s	2	

Weight (mass) kg		
Cylinder series (Basic cylinder)	Weight (Mass) kg	
	At 0 mm stroke	per 100 mm stroke
OSP-P50LS	3,53	0,566
OSP-P63LS	6,41	0,925
OSP-P80LS	12,46	1,262

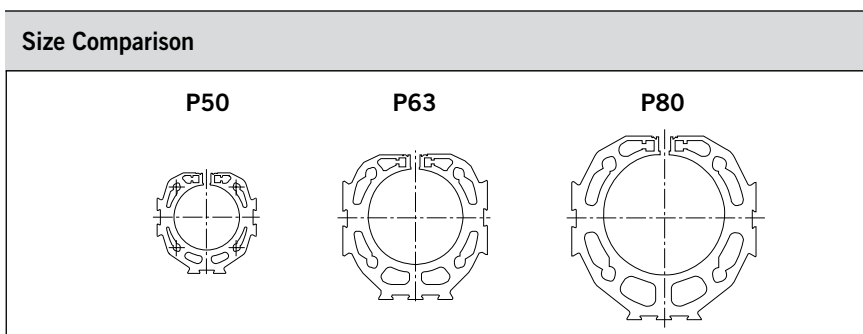

For magnetic switches see 1.45.100E, 1.45.104E, 1.45.105E
Accessories see 1.45.001E to 009E

Rodless Pneumatic Cylinder

Ø 50-80 mm



Long-Stroke Cylinder for strokes up to 41 m

Series OSP-P..LS

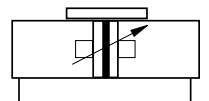

Standard Versions:

- Double-acting with adjustable end cushioning
- With magnetic piston for position sensing

Special Versions:

- Stainless steel screws
- Slow speed lubrication
- Viton® seals

Options:

- Displacement measuring system SFI-plus
- Active Brake AB..

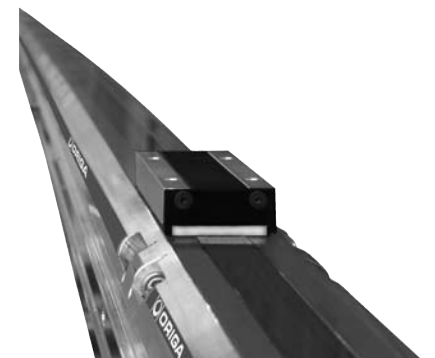

Loads, Forces and Moments

Choice of cylinder is decided by:

- permissible loads, forces and moments
- performance of the pneumatic end cushions. The main factors here are the mass to be cushioned and the piston speed at start of cushioning (unless external cushioning is used, e. g. hydraulic shock absorbers).

The adjacent table shows the maximum values for light, shock-free operation, which must not be exceeded even in dynamic operation. **Load and moment data are based on speeds $v \leq 0.5$ m/s.**

When working out the action force required, it is essential to take into account the friction forces generated by the specific application or load.

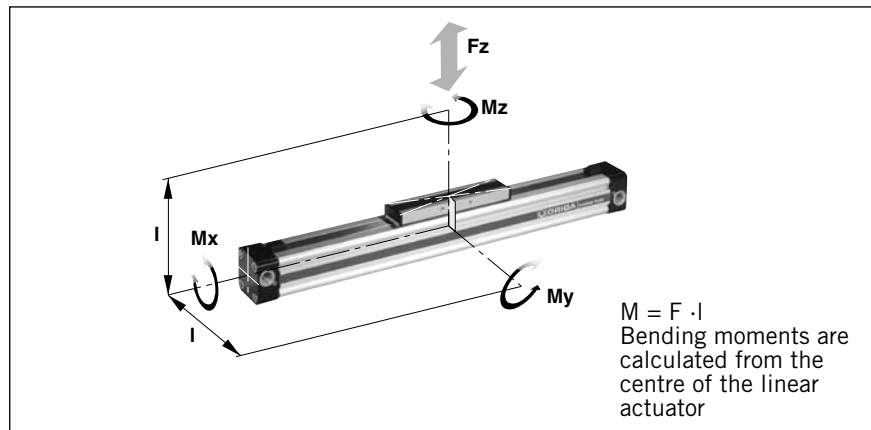

Cylinder-Series [mm Ø]	Theoretical Action Force at 6 bar [N]	effektive Action Force F_A at 6 bar [N]	max. Moments			max. Load F [N]	Cushion Length [mm]
			Mx [Nm]	My [Nm]	Mz [Nm]		
OSP-P50LS	1178	1000	10	115	15	1200	30
OSP-P63LS	1870	1550	12	200	24	1650	32
OSP-P80LS	3016	2600	24	360	48	2400	39

Cushioning Diagram

Work out your expected moving mass and read off the maximum permissible speed at start of cushioning. Alternatively, take your desired speed and expected mass and find the cylinder size required.

Please note that piston speed at start of cushioning is typically ca. 50 % higher than the average speed, and that it is this higher speed which determines the choice of cylinder. If these maximum permissible values are exceeded, additional shock absorbers must be used.

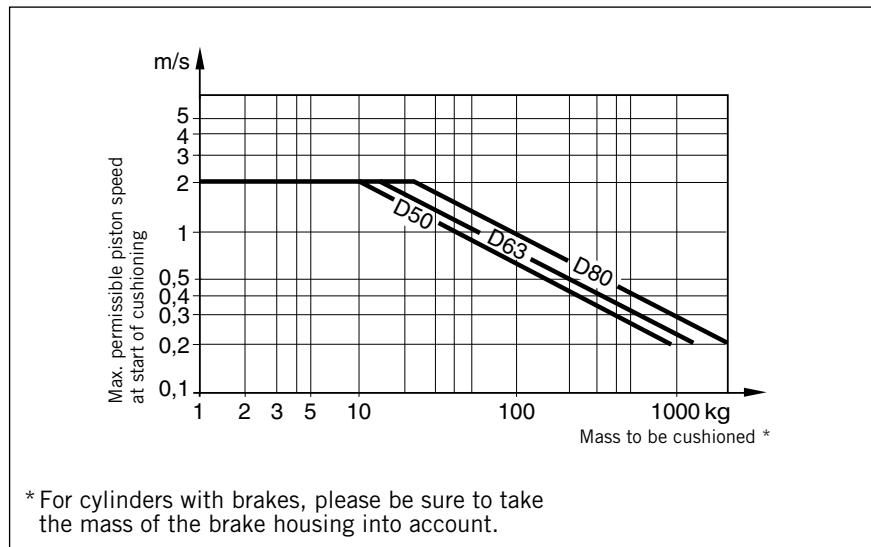

If the permitted limit values are exceeded, additional shock absorbers should be fitted in the area of the centre of gravity .

Dimensions of Basic Cylinder OSP - P50 LS to P80LS

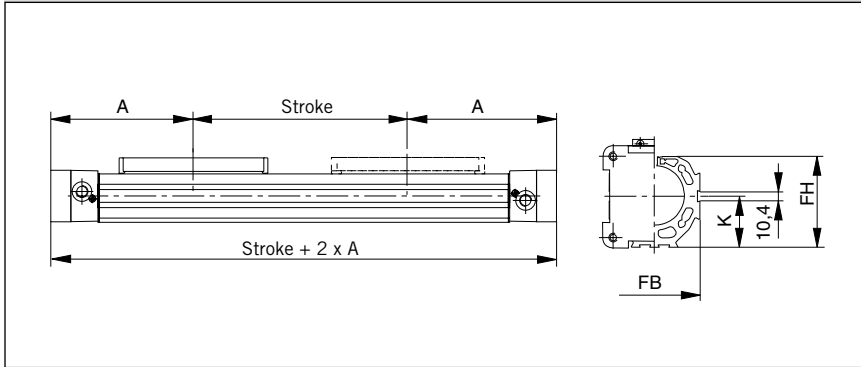

Cylinder Stroke and Dead Length A

- Free choice of stroke length up to 41.000 mm in 1 mm steps

Tandem Cylinder

Two pistons are fitted: dimension "Z" is optional. (Please note minimum distance "Zmin").

- Free choice of stroke length up to 41.000 mm in 1 mm steps
- Stroke length to order is stroke + dimension "Z"

Please note:

To avoid multiple actuation of magnetic switches, the second piston is not equipped with magnets.

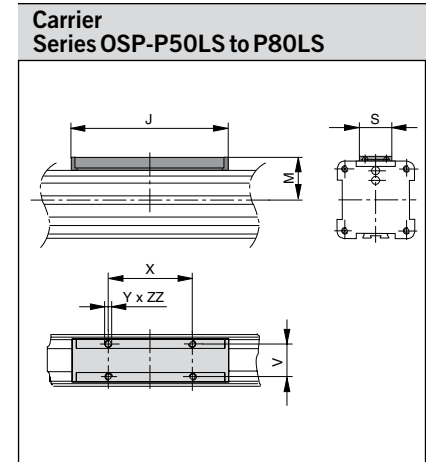
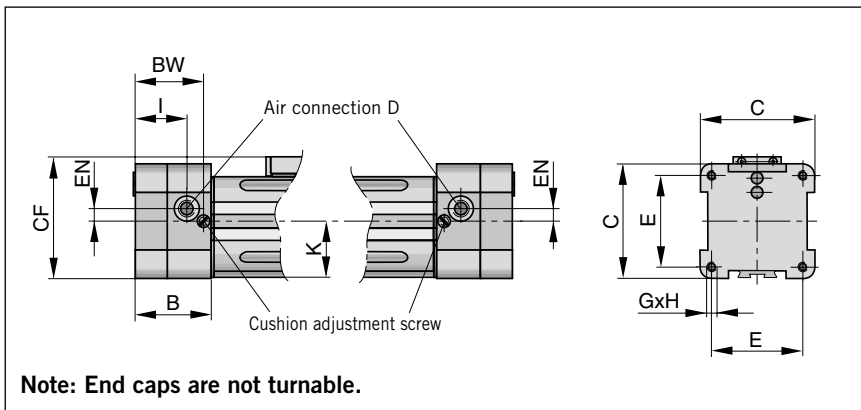
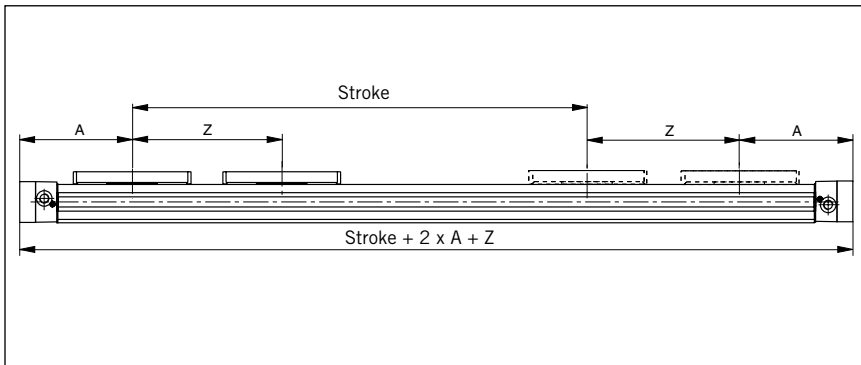

Dimension Table (mm)

Cylinder Series	A	B	C	D	E	G	H	I	J	K	M	S	V	X	Y	Z _{min}	BW	CF	EN	FB	FH	ZZ
OSP-P50LS	200	58	87	G1/4	70	M6	15	39.5	200	43	49	36	27	110	M6	251	52	92.5	10	76	77	10
OSP-P63LS	250	73	106	G3/8	78	M8	21	49.5	256	54	63	50	34	140	M8	313	65	117	12	96	96	16
OSP-P80LS	295	82	132	G1/2	96	M10	25	57	348	67	80	52	36	190	M10	384	72.5	147	16.5	122	122	20

Linear Drive Accessories

Ø 50-80 mm

Mid-Section Support E1, E1L



For linear drive
• Series OSP-P..LS

Note on Types E1 and E1L (P50LS – P80LS):

The mid-section support can also be mounted on the underside of the actuator, in which case its distance from the centre of the actuator is different.

For mounting the Long-Stroke cylinder, a mid-section support Type E1 (fixed support) is required. Depending on the stroke length and the load, additional E1L supports (movable supports) may be required.

For permissible support spacings see diagram.

Stainless steel version on request.



Permissible Support Spacings: OSP - P50LS to P80LS

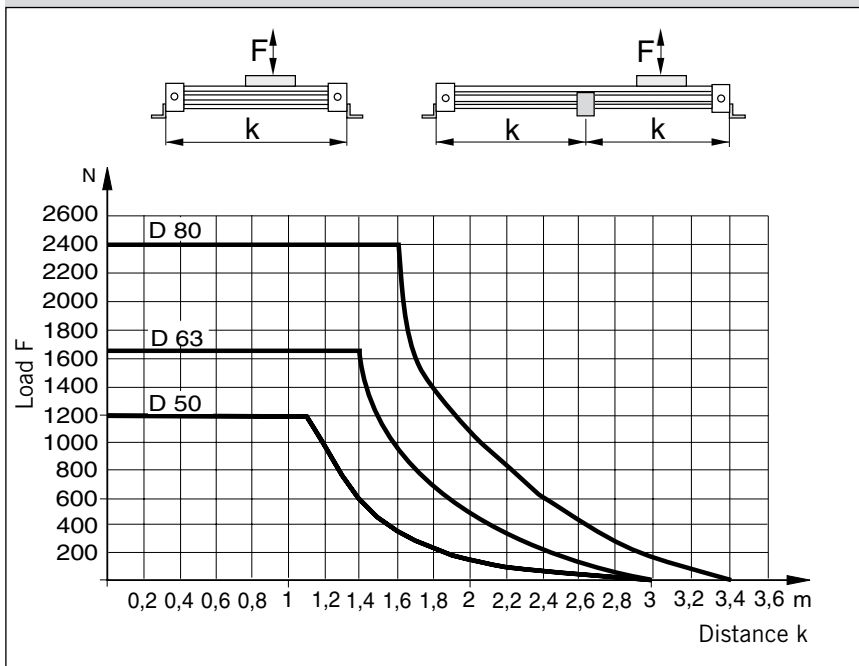

Series OSP-P50LS to P80LS: Type E1, E1L (Mounting from above / below using a cap screw)

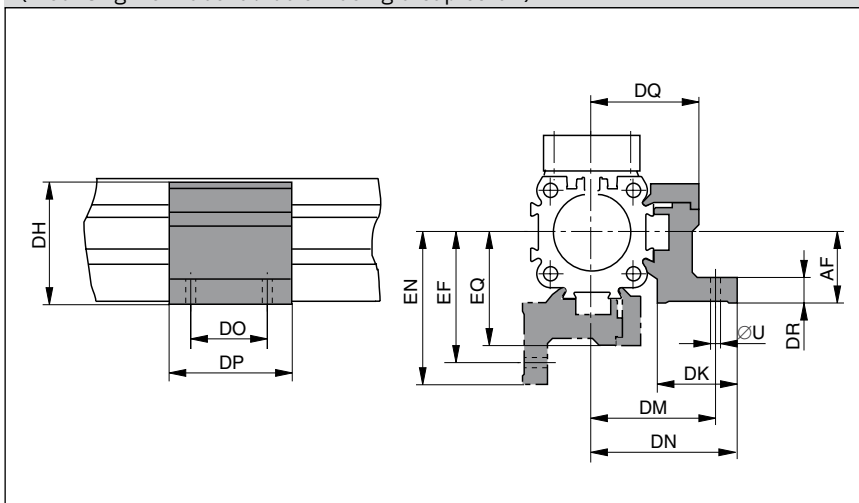

Dimension Table (mm) Series OSP-P50LS to P80LS

Series	R	U	AF	DF	DH	DK	DM	DN	DO	DP
OSP-P50LS	M6	7	48	40	71	34	59	67	45	60
OSP-P63LS	M8	9	57	47.5	91	44	73	83	45	65
OSP-P80LS	M10	11	72	60	111.5	63	97	112	55	80

Series	DQ	DR	DT	EF	EM	EN	EQ	Order No. Type E1 fixed support	Order No. Type E1L movable support
OSP-P50LS	52	10	11	64	45	72	57	20163	21352
OSP-P63LS	63	12	16	79	53.5	89	69	20452	21353
OSP-P80LS	81	15	25	103	66	118	87	20482	21354

Order Instructions – Long-Stroke Cylinder

Note:

Assembly and commissioning of the Long-Stroke cylinder is carried out on site by ORIGA technical personnel.

For more information on ordering and installation please contact your sales or customer service partner.

Accessories - please order separately

Description	Further information see Data Sheet No.
Clevis Mounting	P-1.45.002E
End Cap Mountings	P-1.45.003E
Mid-Section Support	P-1.10.004E-2
Inversion Mounting	P-1.45.006E
Adaptor Profile	P-1.45.007E
T-Slot Profile	P-1.45.008E
Connection Profile	P-1.45.009E
Magnetic Switches	P-1.45.100E, P-1.45.104E, P-1.45.105E
Cable Cover	P-1.45.102E

P-A1P707E00HAD00X

The right to introduce technical modifications is reserved

Characteristics		Pressure quoted as gauge pressure	
Characteristics	Symbol	Unit	Description
General Features			
Type			Rodless Cylinder
Series			OSP-P
System			Double-acting, with cushioning, position sensing capability
Mounting			see drawings
Air connection			Threaded
Ambient and medium temperature range	T _{min} T _{max}	°C °C	-10 – other temperature ranges +80 on request
Weight (Mass)		kg	See table below
Installation			In any position
Medium			Filtered, unlubricated compressed air (other media on request)
Lubrication			Permanent grease lubrication (additional oil mist lubrication not required) Option: special slow speed grease
Material	Cylinder profile		Anodized aluminium
	Carrier (piston)		Anodized aluminium
	End caps		Aluminium, lacquered
	Sealing bands		Corrosion resistant steel
	Seals		NBR (Option: Viton®)
	Screws		Stainless steel
	Covers		Anodized aluminium
	Guide plate		Plastic
Max. operating pressure*	p _{max}	bar	8

* Pressure quoted as gauge pressure

Weight (Mass) kg

Cylinder series (basic cylinder)	Weight (Mass) kg	
	at 0 mm stroke	per 100 mm stroke
OSP-P16	0.22	0.1
OSP-P25	0.65	0.197
OSP-P32	1.44	0.354

Size Comparison

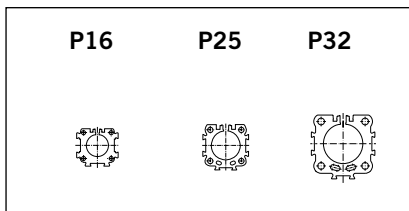

Clean Room Cylinder

Ø 16 – 32 mm

Rodless Cylinder

certified to DIN EN ISO 14644-1



Standard Versions:

- Double-acting with adjustable end cushioning
- With magnetic piston for position sensing
- Stainless steel screws

Special Versions:

- Slow speed lubrication
- Viton® seals

Series OSP-P.

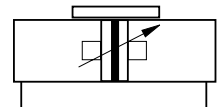

Features:

- Clean room classification
ISO Class 4 at v_m = 0.14 m/s
ISO Class 5 at v_m = 0.5 m/s
- suitable for smooth slow speed operation up to v_{min} = 0.005 m/s
- optional stroke length up to 1200 mm (longer strokes on request)
- Low maintenance
- Compact design with equal force and velocity in both directions
- Aluminium piston with bearing rings to support high direct and cantilever loads



For **magnetic switches** see P-1.45.100E, P-1.45.104E, P-1.45.105E
For **mountings** and **accessories** see P-1.45.001E to 009E

Certification

Based on the Parker Origa rodless cylinder, proven in world wide markets, Parker Origa now offers the only rodless cylinder on the market with a certification from IPA Institute for the cleanroom specification according to DIN EN ISO 14644-1.



Function:

The clean room cylinders of the ORIGA SYSTEM PLUS (OSP-P) combines the efficiency of the Parker Origa slot seal system with vacuum protection against progressive wear and contamination from the sliding components. A partial vacuum drawn between inner and outer sealing bands prevents emission into the clean room. To achieve the necessary vacuum a suction flow of ca. 4 m³/h is required.

Function Diagram

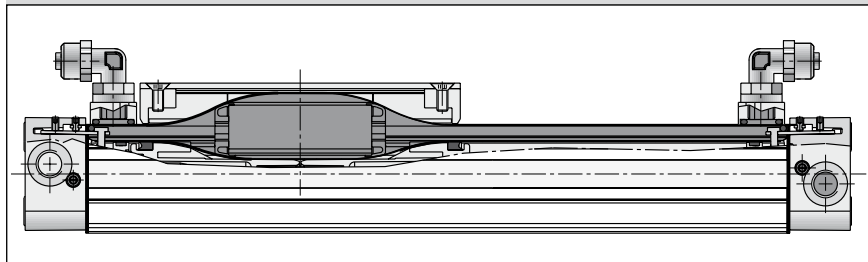

Loads, Forces and Moments

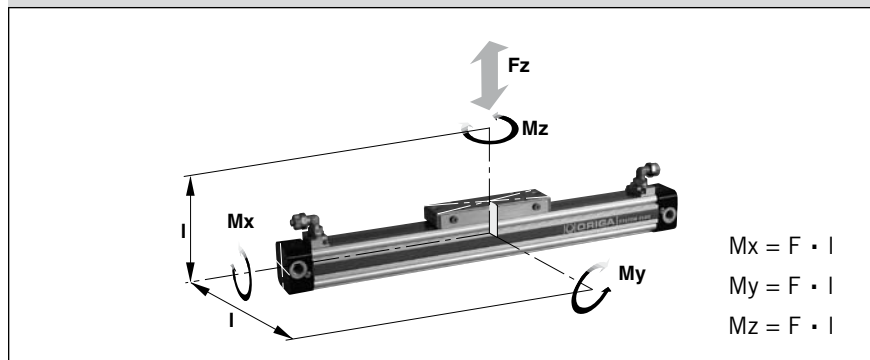

Cylinder Series [mmØ]	Effective Force at 6 bar [N]	Max. Moment			Max. Load Fz [N]	Cushion length [mm]
		Mx [Nm]	My [Nm]	Mz [Nm]		
OSP-P16	78	0.45	4	0.5	120	11
OSP-P25	250	1.5	15	3.0	300	17
OSP-P32	420	3.0	30	5.0	450	20

Load and moment data are based on speeds $v \leq 0.2$ m/s. The adjacent table shows the maximum values for light, shock-free operation which must not be exceeded even in dynamic operation.

Dimensions (mm)

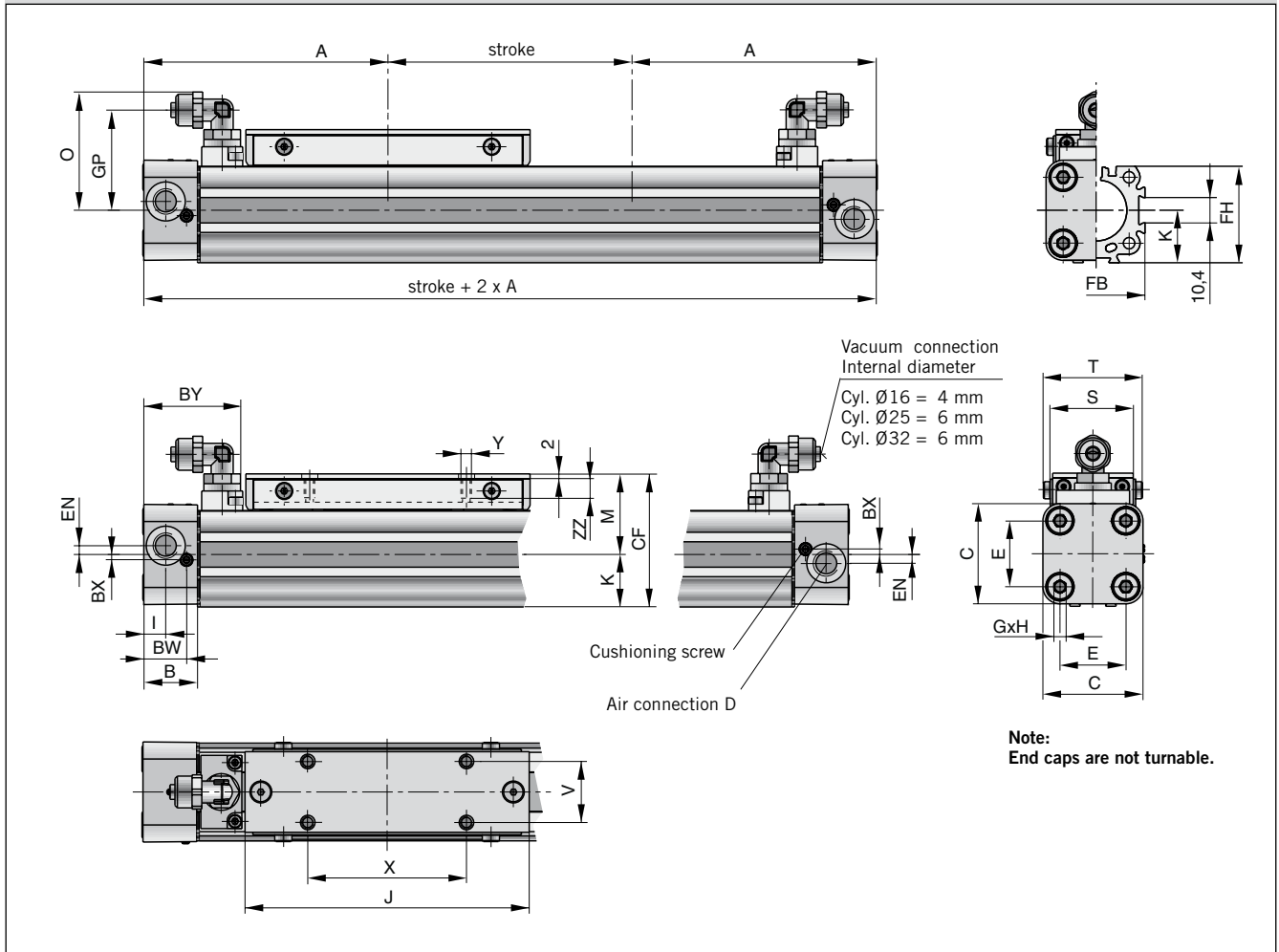

Dimension Table (mm)

Cylinder Series	A	B	C	D	E	G	H	I	J	K	M	O	S
OSP-P16	65	14	30	M5	18	M3	9	5.5	69	15	25	31	24
OSP-P25	100	22	41	G1/8	27	M5	15	9	117	21.5	33	48.5	35
OSP-P32	125	25.5	52	G1/4	36	M6	15	11.5	152	28.5	40	53.6	38

Cylinder Series	T	V	X	Y	BW	BX	BY	CF	EN	FB	FH	GP	ZZ
OSP-P16	29.6	16.5	36	M4	10.8	1.8	28.5	40	3	30	27.2	25.7	7
OSP-P25	40.6	25	65	M5	17.5	2.2	40.5	54.5	3.6	40	39.5	41	8
OSP-P32	45	27	90	M6	20.5	2.5	47.1	68.5	5.5	52	51.7	46.2	10

Order Instructions Basic Cylinders – Clean Room Cylinders

OSP-P 25 - 4 7 0 0 1 - 01000

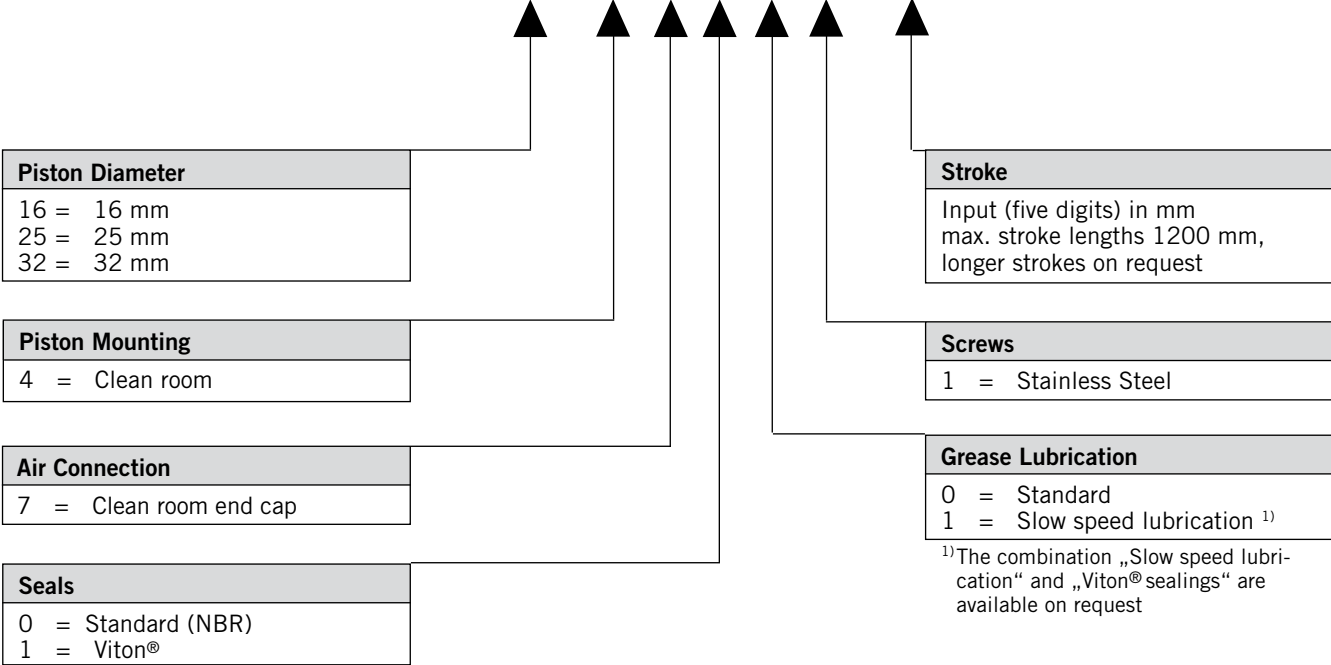

¹⁾The combination „Slow speed lubrication“ and „Viton® sealings“ are available on request

Accessories – please order separately

Benennung	Further information see Data Sheet No.
End Cap Mountings	P-1.45.003E
Mid-Section Support	P-1.45.004E
Adaptor Profile	P-1.45.007E
T-Slot Profile	P-1.45.008E
Connection Profile	P-1.45.009E
Magnetic Switches	P-1.45.100E, P-1.45.104E, P-1.45.105E
Cable Cover	P-1.45.102E

Informations for ATEX-Directives

The rodless pneumatic cylinders of Parker Origa are the first linear drive unit, for that Ex range in the group of equipment II, Category 2 GD are certified.

Detail informations for use pneumatic components in Ex-Areas see leaflet A5P060E "EU Directive 94/9/EG (ATEX 95) for Pneumatic Components".

Components for EX-Areas



Technical Data (deviant to the Standard Cylinder)

Pressure quoted as gauge pressure

Characteristics	Symbol	Unit	Description
Ambient temperature range	T _{min} T _{max}	°C °C	-10 +60
Max. switching frequency		Hz	1 (double stroke/s) Basic cylinder 0.5 (1stroke/s) Cylinder with guide
Operating pressure range	p _{max}	bar	Max. 8
Max. speed	v _{max}	m/s	3 Basic cylinder 2 Cylinder with guide
Medium			Filtered, unlubricated compressed air – free from water and dirt to ISO 8573-1 Solids: Class 7 particle size < 40 µm for Gas Water content: pressure dew point +3 °C, class 4, but at least 5 °C below minimum operating temperature
Noise level		dB (A)	70
Information for materials			Aluminium: see data sheet "Material" Lubrication: see security data sheet "Grease for use in Cylinder with guides" Sealing bands: Corrosion resistant steel

For all other details for dimensions, weights, allowable loads, cushioning diagrams and accessories see data sheets in this catalogue.

Equipment Group II Categorie 2GD

Rodless cylinder: ⓧ II 2GD c T4 T135°C -10°C ≤ Ta ≤ +60°C

Series	Size	Stroke range	Accessories
OSP-P	Ø 10 to 80	1– 6000 mm	Mountings programme
SLIDELINE	Ø 16 to 80	1– 6000 mm	Mountings programme

For **basic cylinder** see P-1.10.002E
For **plain bearing guide SLIDELINE** see P-1.40.002E
For **mountings and accessories** see 1.45.001E to 009E

OSP
ORIGA
SYSTEM
PLUS

Rodless Cylinder Ø 10 – 80 mm Basic Cylinder

Series: OSP-PATEX

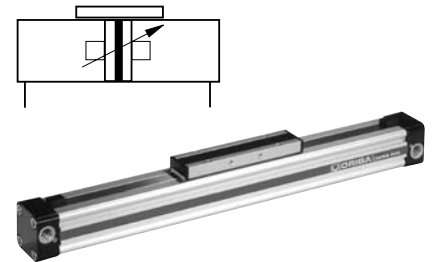

Plain Bearing Guide SLIDELINE Ø 16 – 80 mm

Series: SL -..ATEX



P-A1P708E00HAD00X

The right to introduce technical modifications is reserved

Order Instructions – Basic Cylinder – Series OSP-P..... ATEX

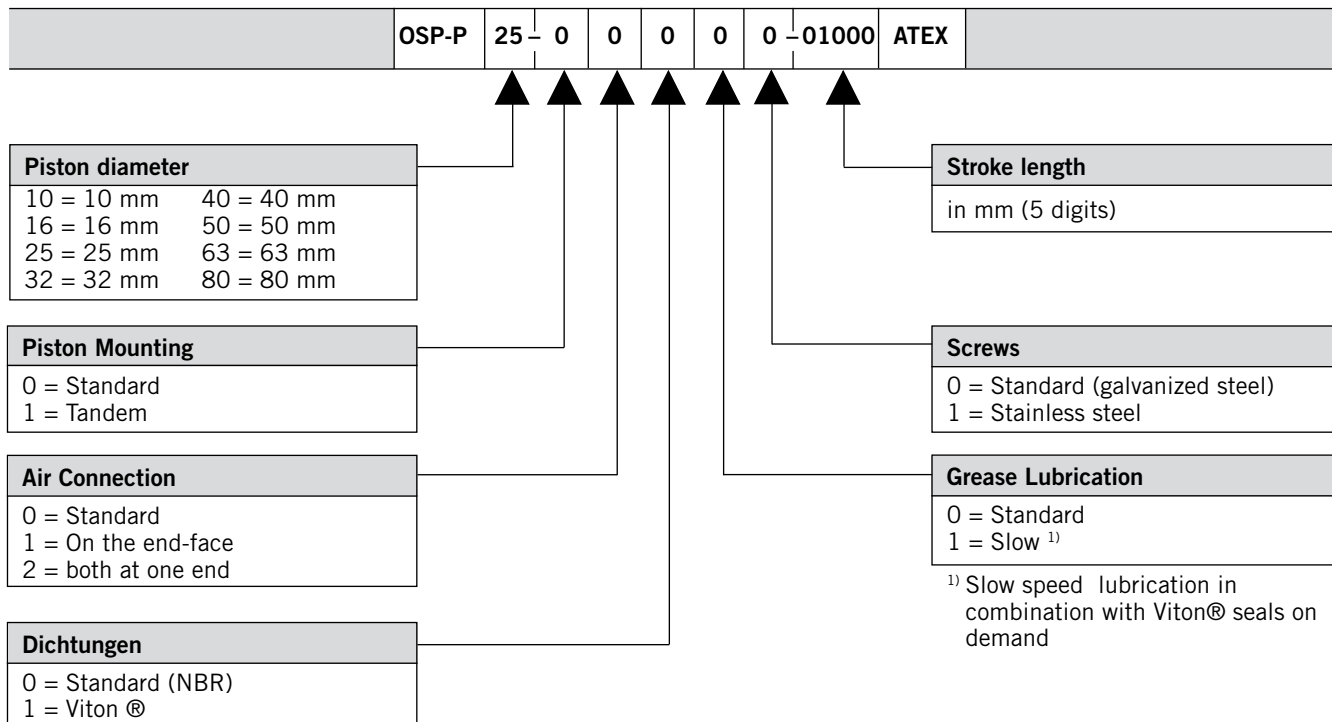

Plain bearing guide SLIDELINE – Series SL..ATEX – the order its only possible in combination with the basic cylinder OSP-P..ATEX!

for Linear Drive	Order instruction *	Order No.
OSP-P16....ATEX	SL-16ATEX	20341
OSP-P25....ATEX	SL-25ATEX	20342
OSP-P32....ATEX	SL-32ATEX	20196
OSP-P40....ATEX	SL-40ATEX	20343
OSP-P50....ATEX	SL-50ATEX	20195
OSP-P63....ATEX	SL-63ATEX	20853
OSP-P80....ATEX	SL-80ATEX	21000

* corrosion resistant version on request

Accessories – please order separately

Description	Further information see Data Sheet No.
Clevis Mounting Ø 16 to Ø 80 mm	P-1.45.002E-2
End Cap Mounting for OSP-P Basic Cylinder	P-1.45.003E
End Cap Mounting for OSP-P Basic Cylinder with SLIDELINE	P-1.45.005E-2
Mid-Section Support for OSP-P Basic Cylinder	P-1.45.004E
Mid-Section Support for OSP-P Basic Cylinder with SLIDELINE	P-1.45.005E-3
Inversion Mounting	P-1.45.006E
Adaptor Profile	P-1.45.007E
T-Slot Profile	P-1.45.008E
Adaptor Profile	P-1.45.009E
Magnetic Switches ATEX-Version	P-1.45.105E
Cable Cover	P-1.45.102E

P-A1P753E00BAG00X

The right to introduce technical modifications is reserved

Characteristics			
Characteristics	Symbol	Unit	Description
General Features			
Type			Rodless cylinder for synchronized bi-parting movements
Series			OSP-P
System			Double acting with end cushioning. For contactless position sensing
Guide			Slideline SL40
Synchronization			Toothed belt
Mounting			See drawings
Ambient temperature range	T_{min} T_{max}	°C °C	-10 +60
Weight (Mass)		kg	see Data Sheet No P-1.10.021E-2
Medium			Filtered, unlubricated compressed air (other media on request)
Lubrication			Special slow speed grease – additional oil mist lubrication not required
Material			
Toothed Belt			Steel-corded polyurethane
Belt wheel			Aluminium
Operating pressure range	p_{max}	bar	6
Cushioning middle position			Elastic buffer
Max. Speed	v_{max}	m/s	0.2
Max. stroke of each stroke		mm	500
Max. mass per guide carrier		kg	25
Max. moments on guide carrier			
lateral moment	Mx_{max}	Nm	25
axial moment	My_{max}	Nm	46
rotating moment	Mz_{max}	Nm	46
For more technical information see Data Sheet No. P-1.10.002E and P-1.40.002E			

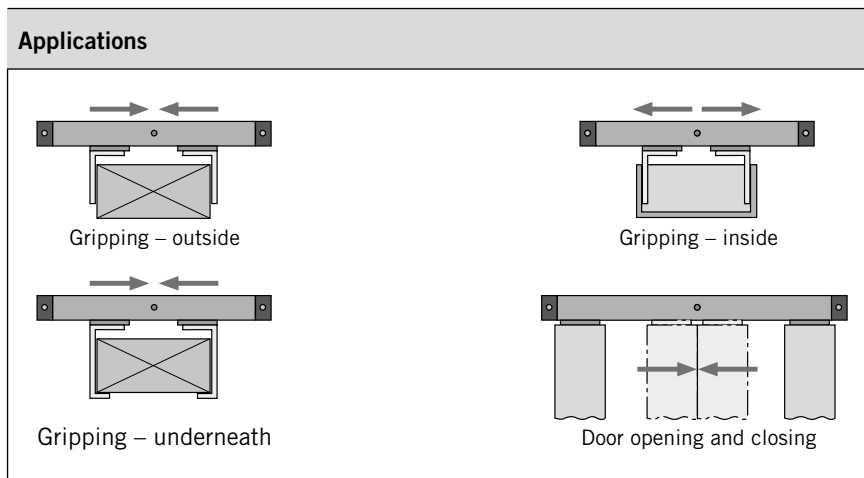

For **Magnetic Switches** see P-1.45.100E, P-1.45.104E, P-1.45.105E

Rodless Cylinder Ø 40 mm

for synchronized
bi-parting movements

Type OSP-P40-SL-BP



Features:

- Accurate bi-parting movement through toothed belt synchronization
- Optimum slow speed performance
- Increased action force
- Anodized aluminium guide rail with prism-form slideway arrangement
- Adjustable polymer slide units
- Combined sealing system with polymer and felt elements to remove dirt and lubricate the slideway
- Integrated grease nipples for guide lubrication

Applications:

- Opening and closing operations
- Gripping of workpieces – outside
- Gripping of hollow workpieces – inside
- Gripping underneath larger objects
- Clamping force adjustable via pressure regulator

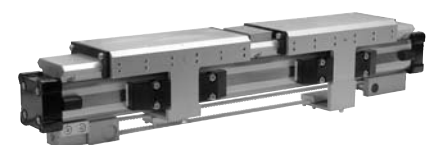

Weight (mass) kg

Cylinder series (Basic cylinder)	Weight (Mass) kg	
	At 0 mm stroke	per 100 mm stroke
OSP-P40-SL-BP	10.33	2.13

Function:

The OSP-P40-SL-BP bidirectional linear drive is based on the OSP-P40 rodless pneumatic cylinder and adapted SLIDELINE SL40 polymer plain-bearing guides.

Two pistons in the cylinder bore are connected via yokes and carriers to the SLIDELINE guide carriers, which handle the forces and moments generated.

The bi-parting movements of the guide carriers are accurately synchronized by a recirculating toothed belt.

The two pistons are driven from the middle to the end positions via a common G1/4 air connection in the middle of the cylinder, and are driven from the end positions to the middle via an air connection in each end cap.

End position cushioning is provided by adjustable air cushioning in the end caps, and middle position cushioning by rubber buffers.

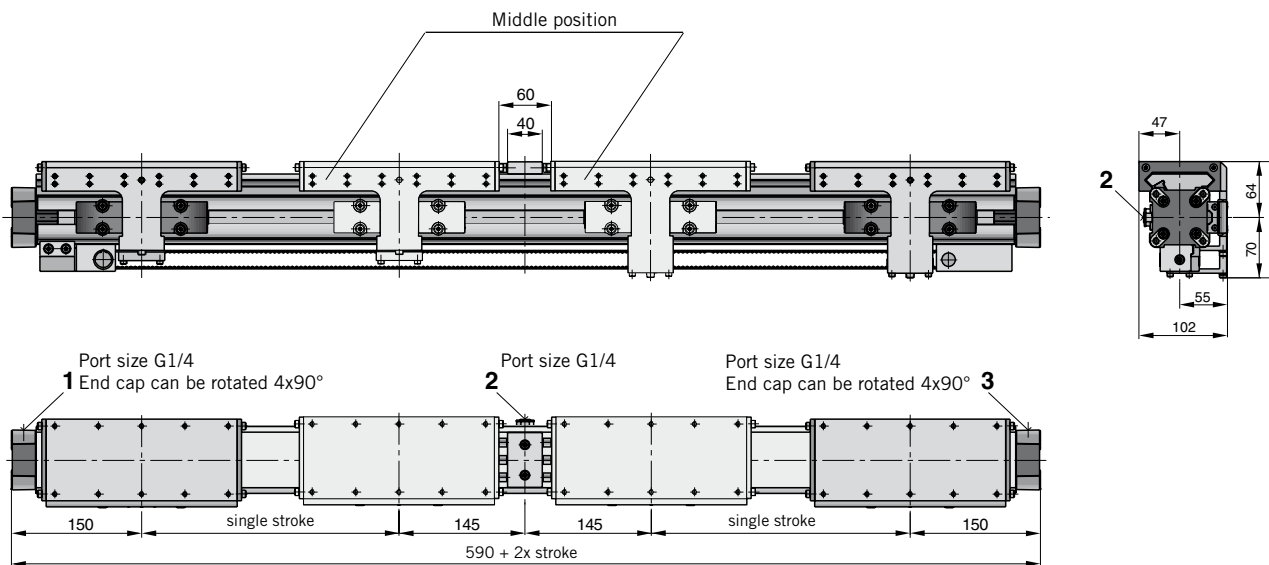
Dimensions (mm)**Air connections:**

To drive the guide carriers to the middle position: pressurize ports 1 and 3.

To drive the guide carriers to the end positions: pressurize port 2.

For more dimensions see data sheet no. P-1.10.002E-5 und P-1.40.002E-2

Order Instructions

Description	Type	Order No.
Rodless cylinder for synchronized bi-parting movements	OSP-P40-SL-BP	21315

Note: Order stroke = 2x single stroke

Linear Guides Series OSP-P

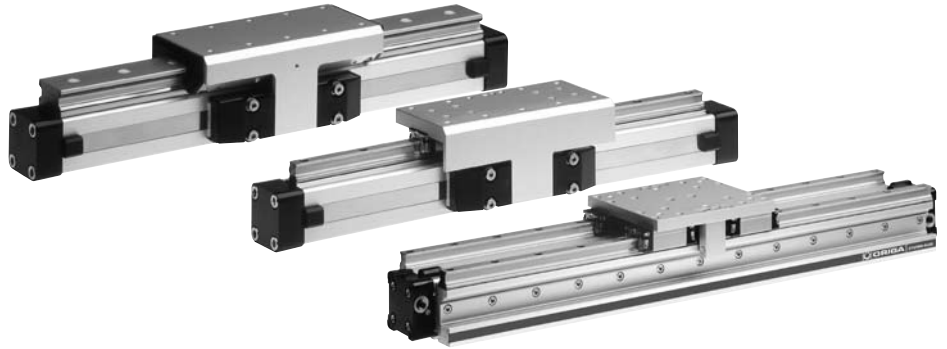

Contents

Description	Data Sheet No.	Page
Overview	P-1.40.001E	39-40
Plain bearing guide SLIDELINE	P-1.40.002E	41-42
Roller guide POWERSLIDE	P-1.40.003E	43-46
Aluminium roller guide PROLINE	P-1.40.005E	47-48
Recirculating ball bearing guide STARLINE	P-1.40.006E	49-54
Recirculating ball bearing guide KF	P-1.40.007E	55-60
Heavy duty guide HD	P-1.40.008E	61-65

Adaptive modular system

The Origa system plus – OSP – provides a comprehensive range of linear guides for the pneumatic and electric linear drives.

Advantages:

- Takes high loads and forces
- High precision
- Smooth operation
- Can be retrofitted
- Can be installed in any position

Rodless Pneumatic Cylinder Series OSP - P

Piston diameters 10 – 80 mm

See data sheet
P-1.10.002E (Standard)
P-1.10.020E (ATEX-Version)

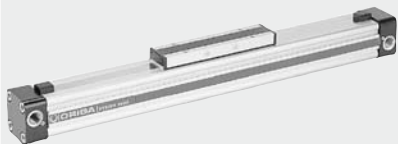

Linear Guides

SLIDELINE

The cost-effective plain bearing guide for medium loads.
Active/ Passive Brake optional.

Piston diameters 16 – 80 mm

See data sheet
P-1.40.002E (Standard)
P-1.10.020E (ATEX-Version)



POWERSLIDE

The roller guide for heavy loads and hard application conditions

Piston diameters 16 – 50 mm

See data sheet 1.40.003E

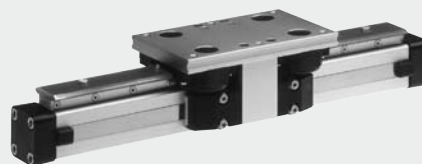

PROLINE

The compact aluminium roller guide for high loads and velocities.

Active/ Passive Brake optional.

Piston diameters 16 – 50 mm

See data sheet no. P-1.40.005E



STARLINE

Recirculating ball bearing guide for very high loads and precision

Piston diameters 16 – 50 mm

See data sheet no. P-1.40.006E

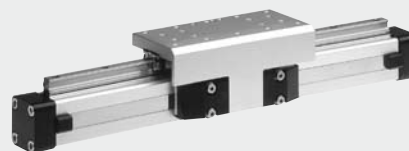

KF GUIDE

Recirculating ball bearing guide for highest loads and precision.

Correspond to FESTO dimensions (Type DGPL-KF)

Piston diameters 16 – 50 mm

See data sheet no. P-1.40.007E



HD HEAVY DUTY GUIDE

The ball bushing guide for the heavy loads and greatest accuracy.

Piston diameters 25 – 50 mm

See data sheet no. P-1.40.008E

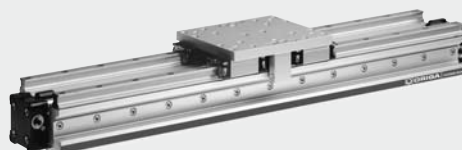

P-A1P539E00HAA00X

The right to introduce technical modifications is reserved

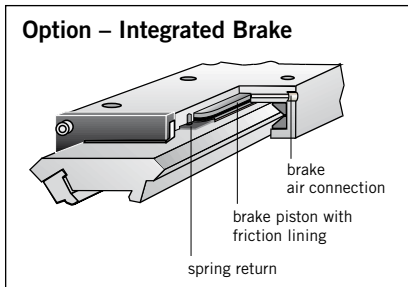
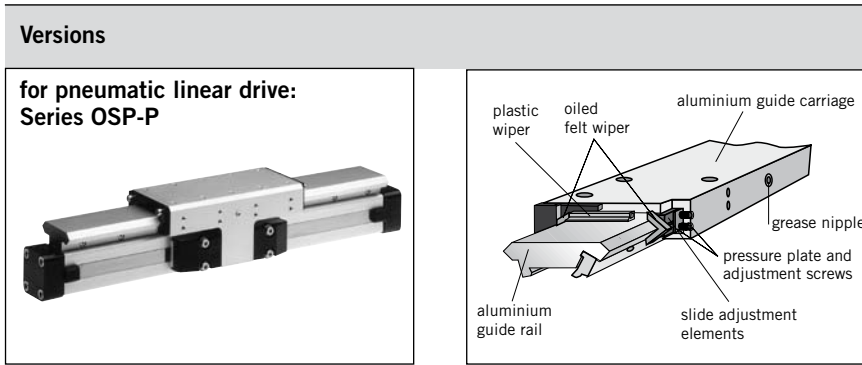

**Integrated Brake (optional)
for series OSP-P25 to OSP-P50:**

- Actuated by pressure
- Released by exhausting and spring return

For further technical data see also linear drives OSP-P (P-1.10.002E)

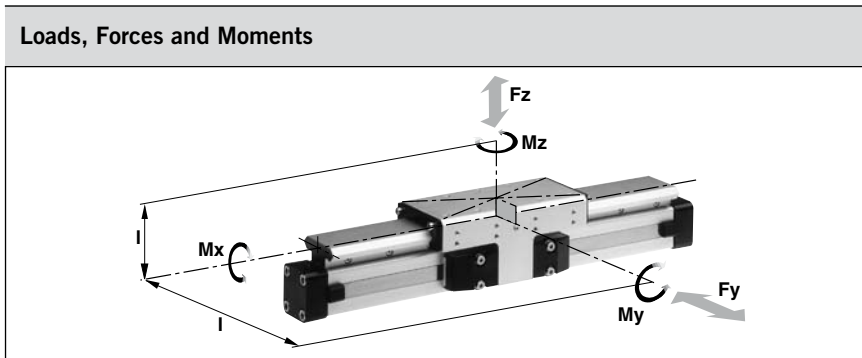

Technical Data

The table shows the maximum permissible values for smooth operation, which should not be exceeded even under dynamic conditions.

The load and moment figures apply to speeds $v < 0.2$ m/s.

*** Please note:**

In the cushioning diagram, add the mass of the guide carriage to the mass to be cushioned.

Plain Bearing Guide SLIDELINE



**Series SL 16 to 80
for Linear-drive**
• Series OSP-P

Features:

- ATEX-version (without brake) is also available (see data sheet no. P-1.10.020E)
- Anodised aluminium guide rail with prism-shaped slideway arrangement
- Adjustable plastic slide elements – optional with integral brake
- Composite sealing system with plastic and felt wiper elements to remove dirt and lubricate the slideways
- Corrosion resistant version available on request
- Any length of stroke up to 5500 mm (longer strokes on request)

¹⁾ Only with integrated brake: Braking force on dry oil-free surface. Values are decreased for lubricated slideways
²⁾ Corrosion resistant fixtures available on request

Series	For linear drive	Max. moments [Nm]			Max. loads [N]	Maximum braking force at 6 bar [N] ¹⁾	Mass of linear drive with guide [kg]		Mass * of guide carriage [kg]	Order No. SLIDELINE ²⁾ for	
		Mx	My	Mz			Fy, Fz	with 0 mm stroke		increase per 100 mm stroke	OSP-P without brake
SL16	OSP-P16	6	11	11	325	–	0.57	0.22	0.23	20341	–
SL25	OSP-P25	14	34	34	675	325	1.55	0.39	0.61	20342	20409
SL32	OSP-P32	29	60	60	925	545	2.98	0.65	0.95	20196	20410
SL40	OSP-P40	50	110	110	1500	835	4.05	0.78	1.22	20343	20411
SL50	OSP-P50	77	180	180	2000	1200	6.72	0.97	2.06	20195	20412
SL63	OSP-P63	120	260	260	2500	–	11.66	1.47	3.32	20853	–
SL80	OSP-P80	120	260	260	2500	–	15.71	1.81	3.32	21000	–

For linear drives see P-1.10.002E, **for ATEX-version** see P-1.10.020E
For mountings see P-1.45.005E

Dimensions

Series OSP-P

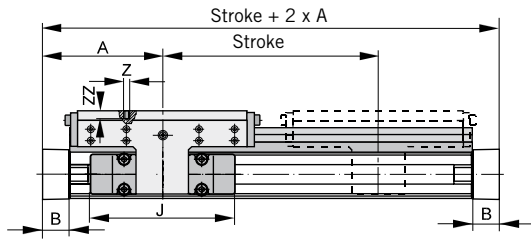

Air connection for brake (Option)

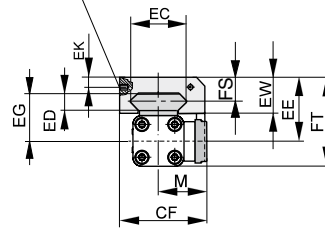

For further mounting elements and options see accessories.

For further information and technical data see data sheets for linear drives OSP-P (P-1.10.002E)

Air connection for brake (Option)

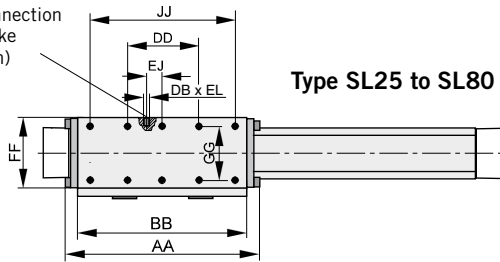

Type SL25 to SL80

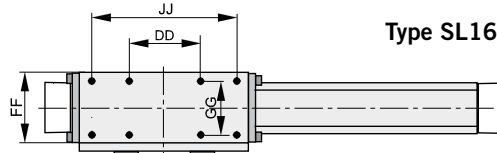

Type SL16

Dimension Table (mm)

Series	A	B	J	M	Z	AA	BB	DB	DD	CF	EC	ED	EE	EG	EJ	EK	EL	EW	FF	FT	FS	GG	JJ	ZZ
SL16	65	14	69	31	M4	106	88	-	30	55	36	8	40	30	-	-	-	22	48	55	14	36	70	8
SL25	100	22	117	40.5	M6	162	142	M5	60	72.5	47	12	53	39	22	6	6	30	64	73.5	20	50	120	12
SL32	125	25.5	152	49	M6	205	185	M5	80	91	67	14	62	48	32	6	6	33	84	88	21	64	160	12
SL40	150	28	152	55	M6	240	220	M5	100	102	77	14	64	50	58	6	6	34	94	98.5	21.5	78	200	12
SL50	175	33	200	62	M6	284	264	M5	120	117	94	14	75	56	81	6	6	39	110	118.5	26	90	240	16
SL63	215	38	256	79	M8	312	292	-	130	152	116	18	86	66	-	-	-	46	152	139	29	120	260	14
SL80	260	47	348	96	M8	312	292	-	130	169	116	18	99	79	-	-	-	46	152	165	29	120	260	14

Mid-Section Support

(for versions see P-1.45.005E)

Mid-section supports are required from a certain stroke length to prevent excessive deflection and vibration of the linear drive. The diagrams show the maximum permissible unsupported length in relation to loading. A distinction must be drawn between loading 1 and loading 2. Deflection of 0.5 mm max. between supports is permissible.

Note:

For speeds $v > 0.5$ m/s the distance between supports should not exceed 1 m.

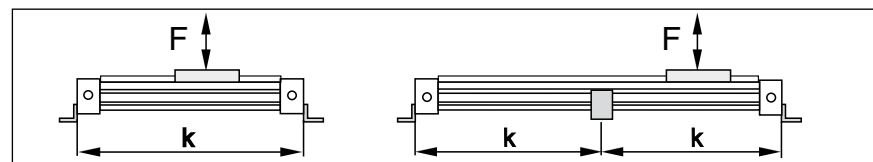
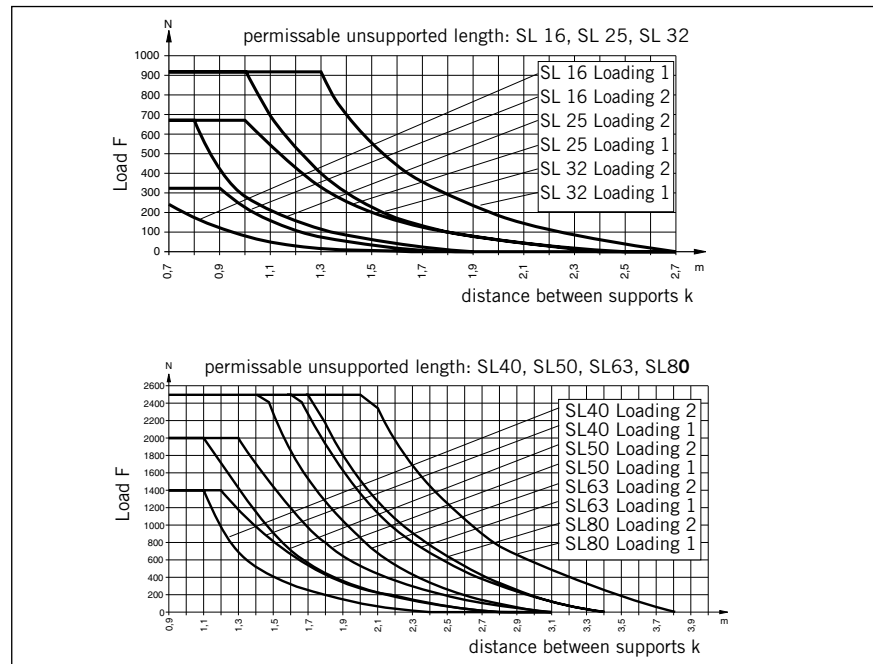
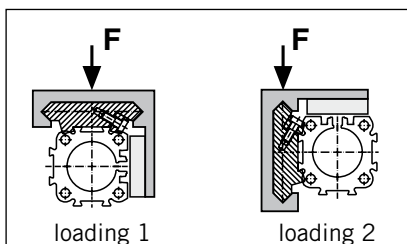

P-A1P540E00DZ00X

The right to introduce technical modifications is reserved

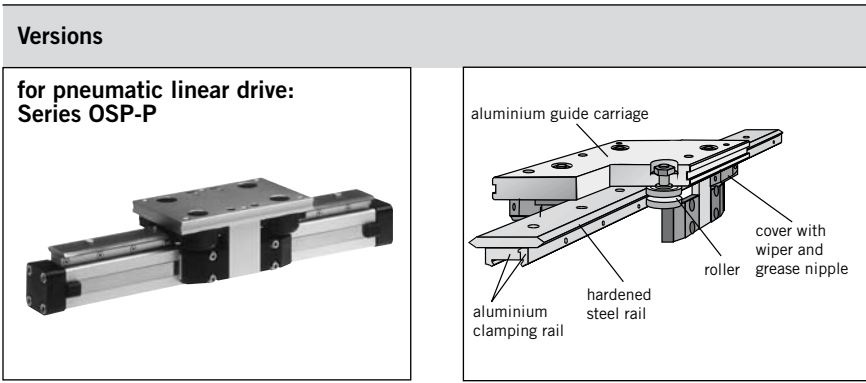

Roller Guide POWERSLIDE



Series PS 16 to 50
for Linear-drive
• Series OSP-P

Loads, Forces and Moments

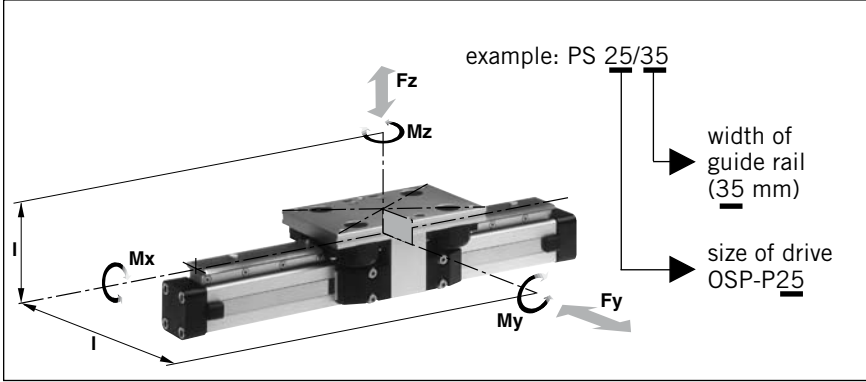

Technical Data

The Table shows the maximum permissible values for smooth operation, which should not be exceeded even under dynamic conditions. For further information and technical data see data sheets for linear drives OSP-P (P-1.10.002E).

*** Please note:**
In the cushioning diagram, add the mass of the guide carriage to the mass to be cushioned.

Features:

- Anodised aluminium guide carriage with vee rollers having 2 rows of ball bearings
- Hardened steel guide rail
- Several guide sizes can be used on the same drive
- Corrosion resistance version available on request
- Max. speed $v = 3 \text{ m/s}$,
- Tough roller cover with wiper and grease nipple
- Any length of stroke up to 3500 mm, (longer strokes on request)

Series	For linear drive	Max. moments [Nm]			Max. load [N]	Mass of linear drive with guide [kg]		Mass * of guide carriage [kg]	Order-No. Powerslide for OSP-P ¹⁾
		Mx	My	Mz		Fy, Fz	with 0 mm stroke		
PS 16/25	OSP-P16	14	45	45	1400	0.93	0.24	0.7	20285
PS 25/25	OSP-P25	14	63	63	1400	1.5	0.4	0.7	20015
PS 25/35	OSP-P25	20	70	70	1400	1.7	0.4	0.8	20016
PS 25/44	OSP-P25	65	175	175	3000	2.6	0.5	1.5	20017
PS 32/35	OSP-P32	20	70	70	1400	2.6	0.6	0.8	20286
PS 32/44	OSP-P32	65	175	175	3000	3.4	0.7	1.5	20287
PS 40/44	OSP-P40	65	175	175	3000	4.6	1.1	1.5	20033
PS 40/60	OSP-P40	90	250	250	3000	6	1.3	2.2	20034
PS 50/60	OSP-P50	90	250	250	3000	7.6	1.4	2.3	20288
PS 50/76	OSP-P50	140	350	350	4000	11.5	1.8	4.9	20289

¹⁾ corrosion resistance version available on request (max. loads and moments are 25% lower)

For linear drives see P-1.10.002E
For mountings see P-1.45.005E

Dimensions

Series OSP-P

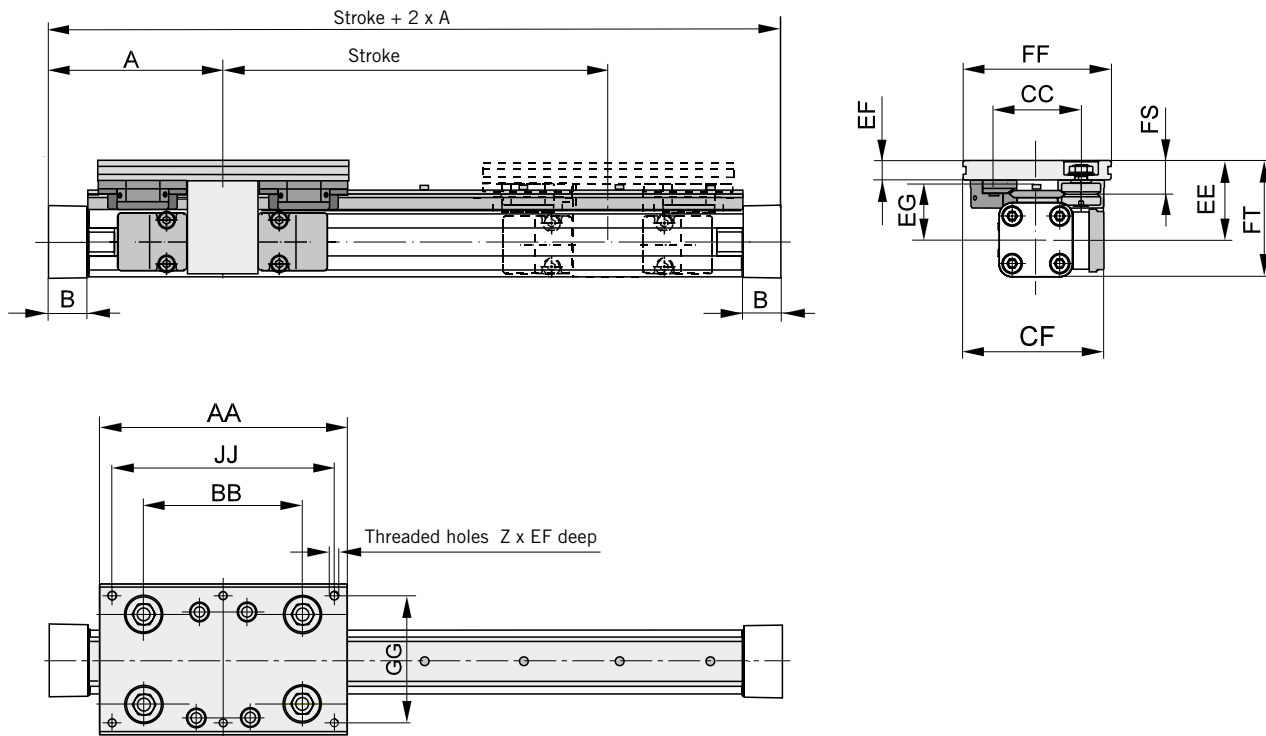

Dimension Table (mm)

Series	A	B	Z	AA	BB	CC	CF	EE	EF	EG	FF	FS	FT	GG	JJ
PS 16/25	65	14	4xM6	120	65	47	80	49	12	35	80	21	64	64	100
PS 25/25	100	22	6xM6	145	90	47	79.5	53	11	39	80	20	73.5	64	125
PS 25/35	100	22	6xM6	156	100	57	89.5	52.5	12.5	37.5	95	21.5	73	80	140
PS 25/44	100	22	6xM8	190	118	73	100	58	15	39	116	26	78.5	96	164
PS 32/35	125	25.5	6xM6	156	100	57	95.5	58.5	12.5	43.5	95	21.5	84.5	80	140
PS 32/44	125	25.5	6xM8	190	118	73	107	64	15	45	116	26	90	96	164
PS 40/44	150	28	6xM8	190	118	73	112.5	75	15	56	116	26	109.5	96	164
PS 40/60	150	28	6xM8	240	167	89	122.5	74	17	54	135	28.5	108.5	115	216
PS 50/60	175	33	6xM8	240	167	89	130.5	81	17	61	135	28.5	123.5	115	216
PS 50/76	175	33	6xM10	280	178	119	155.5	93	20	64	185	39	135.5	160	250

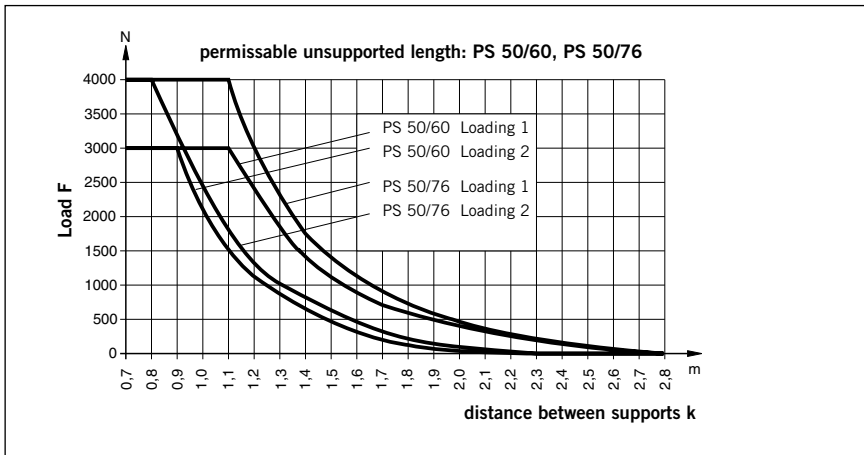
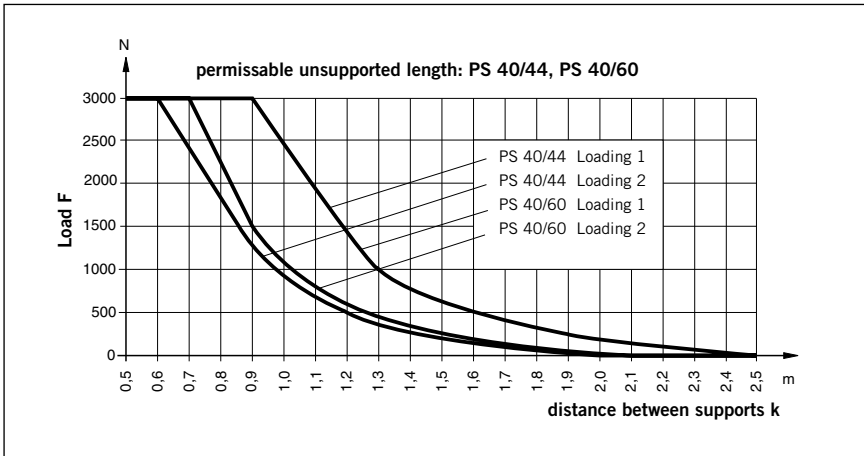
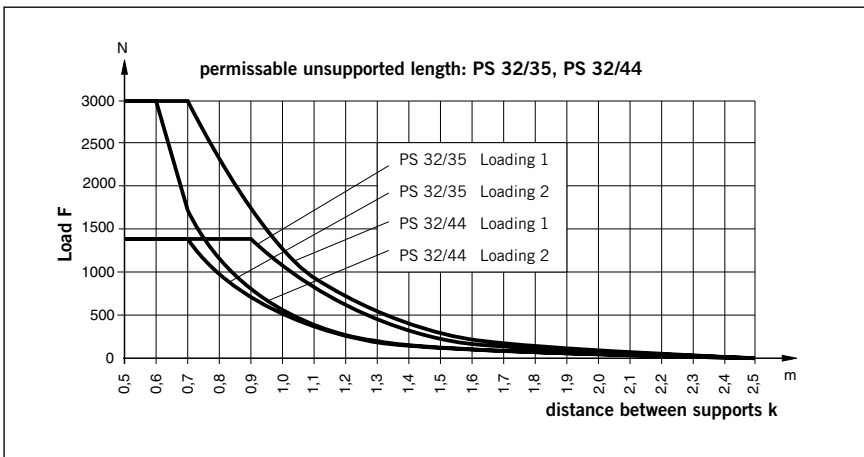
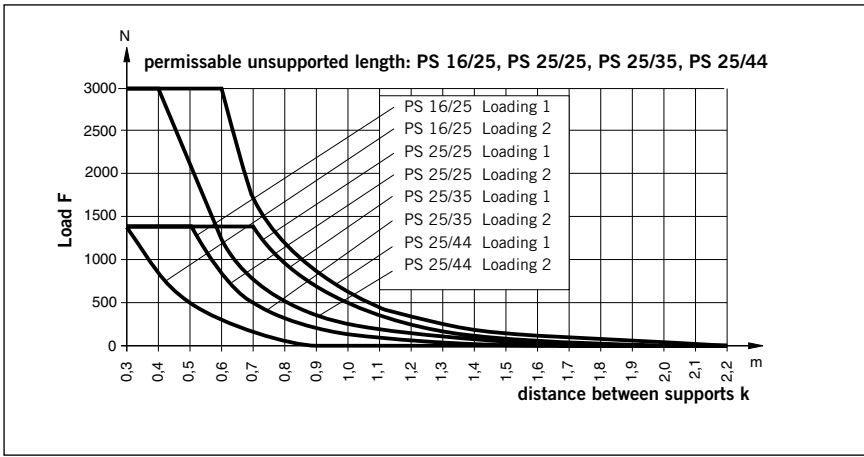

Mid-Section Support

(for versions, see accessories)

Mid section supports are required from a certain stroke length to prevent excessive deflection and vibration of the linear drive. The diagrams show the maximum permissible unsupported length in relation to loading. A distinction must be drawn between loading 1 and loading 2. Deflection of 0.5 mm max. between supports is permissible.

Note

For speeds $v > 0.5$ m/s the distance between supports should not exceed 1m.

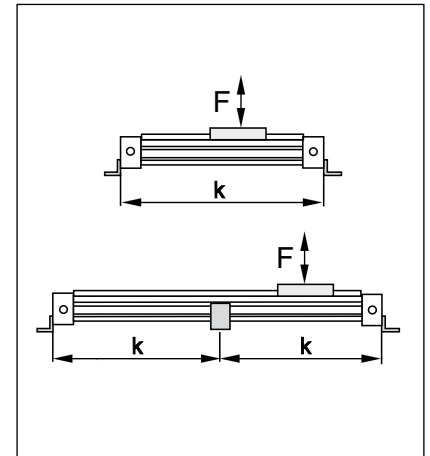
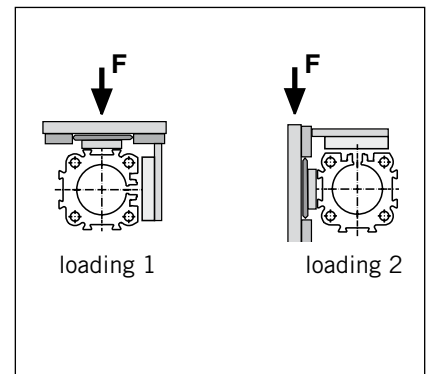

For further mounting elements and options see P-1.45.001E.

Service life

Calculation of service life is achieved in two stages:

- Determination of load factor L_F from the loads to be carried
- Calculation of service life in km

1. Calculation of load factor L_F

$$L_F = \frac{M_x}{M_{x_{max}}} + \frac{M_y}{M_{y_{max}}} + \frac{M_z}{M_{z_{max}}} + \frac{F_y}{F_{y_{max}}} + \frac{F_z}{F_{z_{max}}}$$

with combined loads, L_F should not exceed the value 1.

Lubrication

For maximum system life, lubrication of the rollers must be maintained at all times.

Only high quality Lithium based greases should be used.

Lubrication intervals are dependant on environmental conditions (temperature, running speed, grease quality etc.) therefore the installation should be regularly inspected.

2. Service life calculation

• For PS 16/25, PS 25/25, PS 25/35, and PS 32/35	Service life [km] = $\frac{106}{(L_F + 0,02)^3}$
• For PS 25/44, PS 32/44, PS 40/44, PS 40/60 and PS 50/60:	Service life [km] = $\frac{314}{(L_F + 0,015)^3}$
• For PS 50/76:	Service life [km] = $\frac{680}{(L_F + 0,015)^3}$

P-A1 P539E00HAA00X

The right to introduce technical modifications is reserved

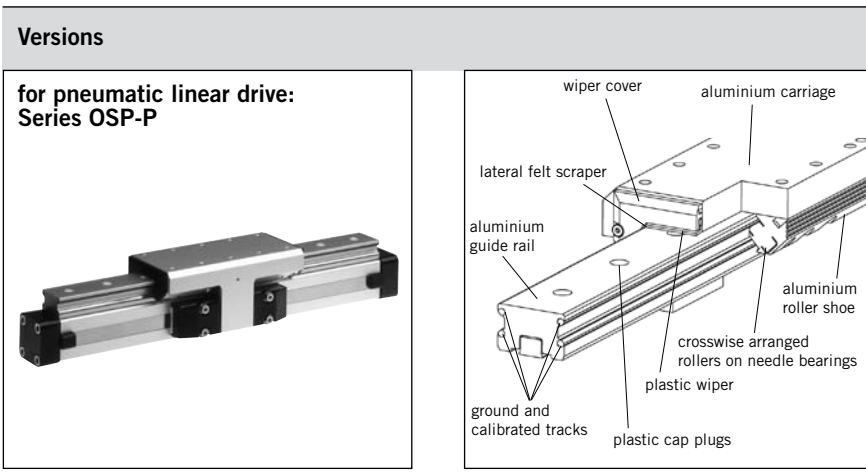

Aluminium Roller Guide PROLINE



Series PL 16 to 50
for Linear-drive
• Series OSP-P

Technical Data

The table shows the maximal permissible loads. If multiple moments and forces act upon the cylinder simultaneously, the following equation applies:

$$\frac{M_x}{M_{x_{max}}} + \frac{M_y}{M_{y_{max}}} + \frac{M_z}{M_{z_{max}}} + \frac{F_y}{F_{y_{max}}} + \frac{F_z}{F_{z_{max}}} \leq 1$$

The sum of the loads should not exceed >1.
With a load factor of less than 1, service life is 8000 km

The table shows the maximum permissible values for light, shock-free operation, which must not be exceeded even under dynamic conditions.

Option – Integrated Brake

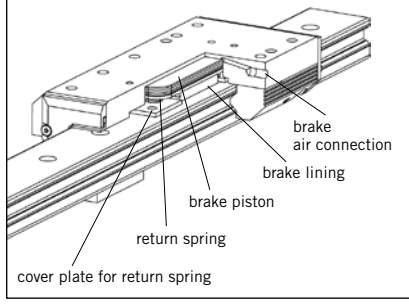

Features:

- High precision
- High velocities (10 m/s)
- Smooth operation - low noise
- Integrated wiper system
- Long life lubrication
- Compact dimensions - compatible to Slideline plain bearing guide
- Any length of stroke up to 3750 mm

Integrated Brake (optional) for Series OSP-P25 to OSP-P50:

- Actuated by pressurisation
- Release by depressurisation and spring actuation

Loads, Forces and Moments

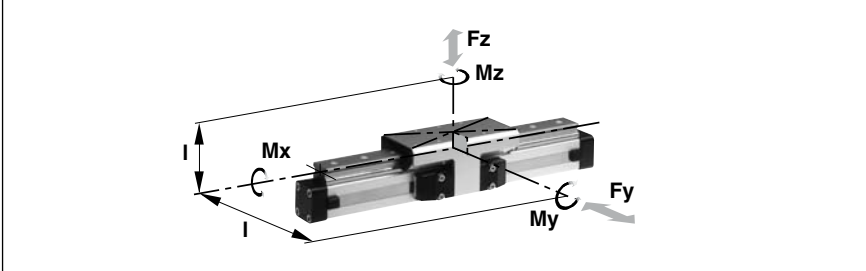

* Please note:

The mass of the carriage has to be added to the total moving mass when using the cushioning diagram.

Series	For linear drive	Max. moments [Nm]			Max. loads [N] Fy, Fz	Maximum braking force at 6 bar [N] ¹⁾	Mass of linear drive with guide [kg]		Mass * guide carriage [kg]	Order No. PROLINE for OSP-P	
		Mx	My	Mz			with 0 mm stroke	increase per 100 mm stroke		without brake	with brake
PL 16	OSP-P16	8	12	12	542	-	0.55	0.19	0.24	20855	-
PL 25	OSP-P25	16	39	39	857	on request	1.65	0.40	0.75	20856	20860
PL 32	OSP-P32	29	73	73	1171	on request	3.24	0.62	1.18	20857	20861
PL 40	OSP-P40	57	158	158	2074	on request	4.35	0.70	1.70	20858	20862
PL 50	OSP-P50	111	249	249	3111	on request	7.03	0.95	2.50	20859	20863

¹⁾ Only for version with brake:
Braking surface dry – oiled surface reduces the effective braking force.

For linear drives see P-1.10.002E
For mountings see P-1.45.005E

Dimension Table (mm) Series OSP-P PL16, PL25, PL32, PL40, PL50

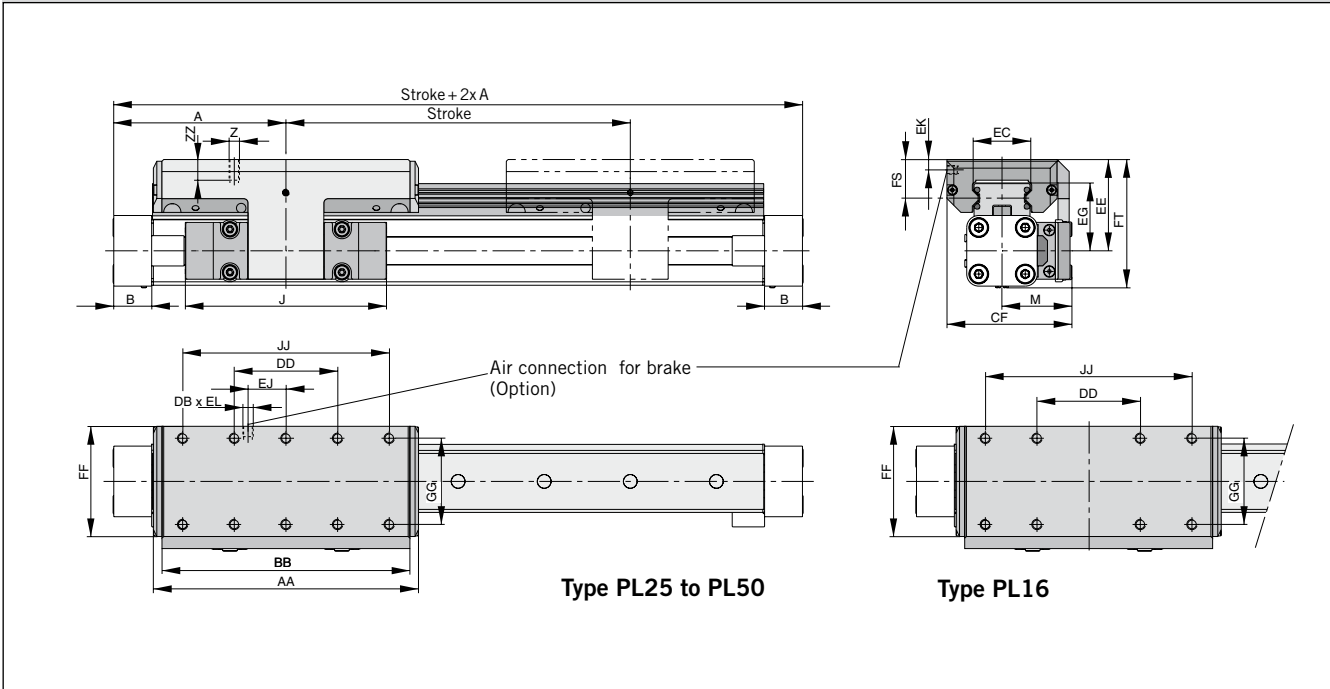

Dimension Table (mm) Series OSP-P PL16, PL25, PL32, PL40, PL50

Series	A	B	J	M	Z	AA	BB	DB	DD	CF	EC	EE	EG	EJ	EK	EL	FF	FS	FT	GG	JJ	ZZ
PL16	65	14	69	31	M4	98	88	-	30	55	23	40	30	-	-	-	48	17	55	36	70	8
PL25	100	22	117	40.5	M6	154	144	M5	60	72.5	32.5	53	39	22	6	6	64	23	73.5	50	120	12
PL32	125	25.5	152	49	M6	197	187	M5	80	91	42	62	48	32	6	6	84	25	88	64	160	12
PL40	150	28	152	55	M6	232	222	M5	100	102	47	64	50.5	58	6	6	94	23.5	98.5	78	200	12
PL50	175	33	200	62	M6	276	266	M5	120	117	63	75	57	81	6	6	110	29	118.5	90	240	16

Mid-Section Support

(For versions, see P-1.45.005E)
Mid-section supports are required from a certain stroke length to prevent excessive deflection and vibration of the linear drive. The diagrams show the maximum permissible unsupported length in relation to loading. A distinction must be drawn between loading 1 and loading 2. Deflection of 0.5 mm max. between supports is permissible.

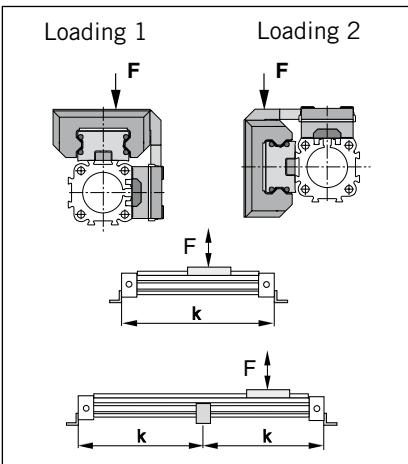

Note:

For speeds $v > 0.5$ m/s the distance between supports should not exceed 1 m.

Permissible Unsupported Length PL16, PL25, PL32, PL40 und PL50

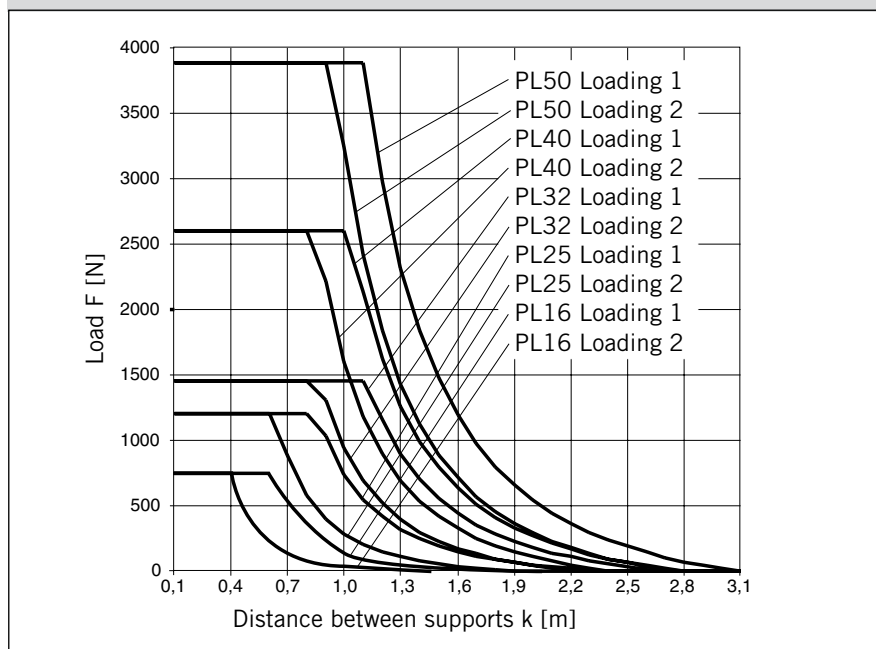

P-A1P704E00HAE00X

The right to introduce technical modifications is reserved

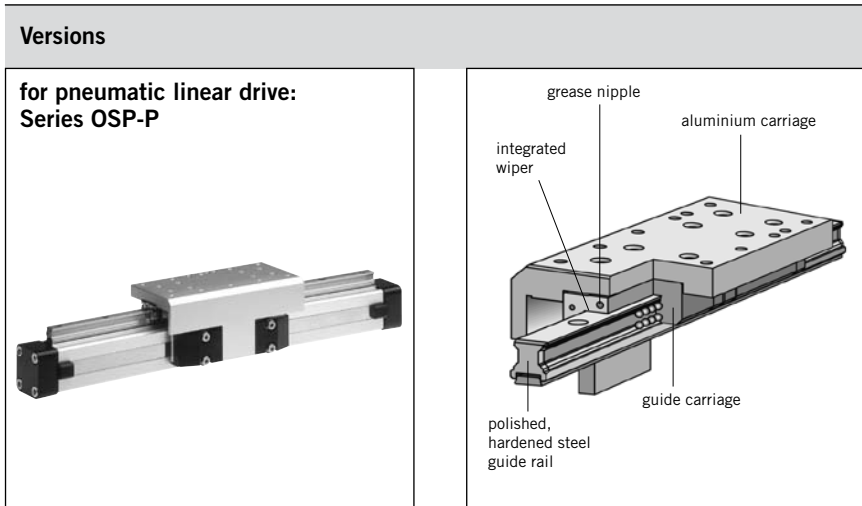

Recirculating Ball Bearing Guide STARLINE



Series STL 16 to 50
for Linear Drive Series OSP-P

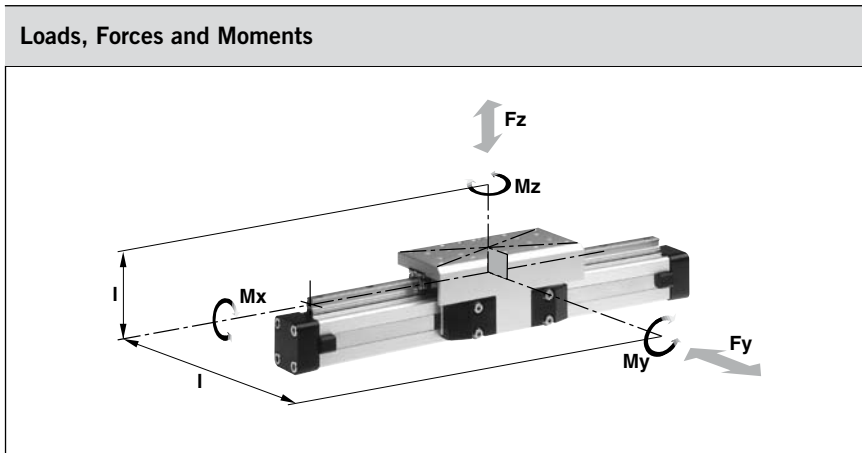

Features:

- Polished and hardened steel guide rail
- For very high loads in all directions
- High precision
- Integrated wiper system
- Integrated grease nipples
- Any length of stroke up to 3700 mm
- Anodized aluminium guide carriage – dimensions compatible with OSP guides SLIDELINE and PROLINE
- Installation height (STL16 - 32) compatible with OSP guides SLIDELINE and PROLINE
- Maximum speed
STL16: v = 3 m/s
STL25 to 50: v = 5 m/s

Technical Data

The table shows the maximum permissible loads. If multiple moments and forces act upon the cylinder simultaneously, the following equation applies:

$$\frac{M_x}{M_{x_{max}}} + \frac{M_y}{M_{y_{max}}} + \frac{M_z}{M_{z_{max}}} + \frac{F_y}{F_{y_{1max}}} + \frac{F_z}{F_{z_{max}}} \leq 1$$

The table shows the maximum permissible values for light, shock-free operation, which must not be exceeded even under dynamic conditions.

The sum of the loads should not exceed >1

** Please note:

The mass of the carriage has to be added to the total moving mass when using the cushioning diagram.

Series	For linear drive	Max. moments [Nm]			Max. loads [N]		Mass of linear drive with guide [kg]		Mass ** guide carriage [kg]	Order No. STARLINE for OSP-P
		Mx	My	Mz	Fy	Fz	with 0 mm stroke	increase per 100 mm stroke		
STL16	OSP-P16	15	30	30	1000	1000	0.598	0.210	0.268	21111
STL25	OSP-P25	50	110	110	3100	3100	1.733	0.369	0.835	21112
STL32	OSP-P32	62	160	160	3100	3100	2.934	0.526	1.181	21113
STL40	OSP-P40	150	400	400	4000	7500	4.452	0.701	1.901	21114
STL50	OSP-P50	210	580	580	4000	7500	7.361	0.936	2.880	21115

For **linear drives** see P-1.10.002E
For **mountings** see P-1.45.005E

Dimensions Series OSP-P STL16 to STL 50

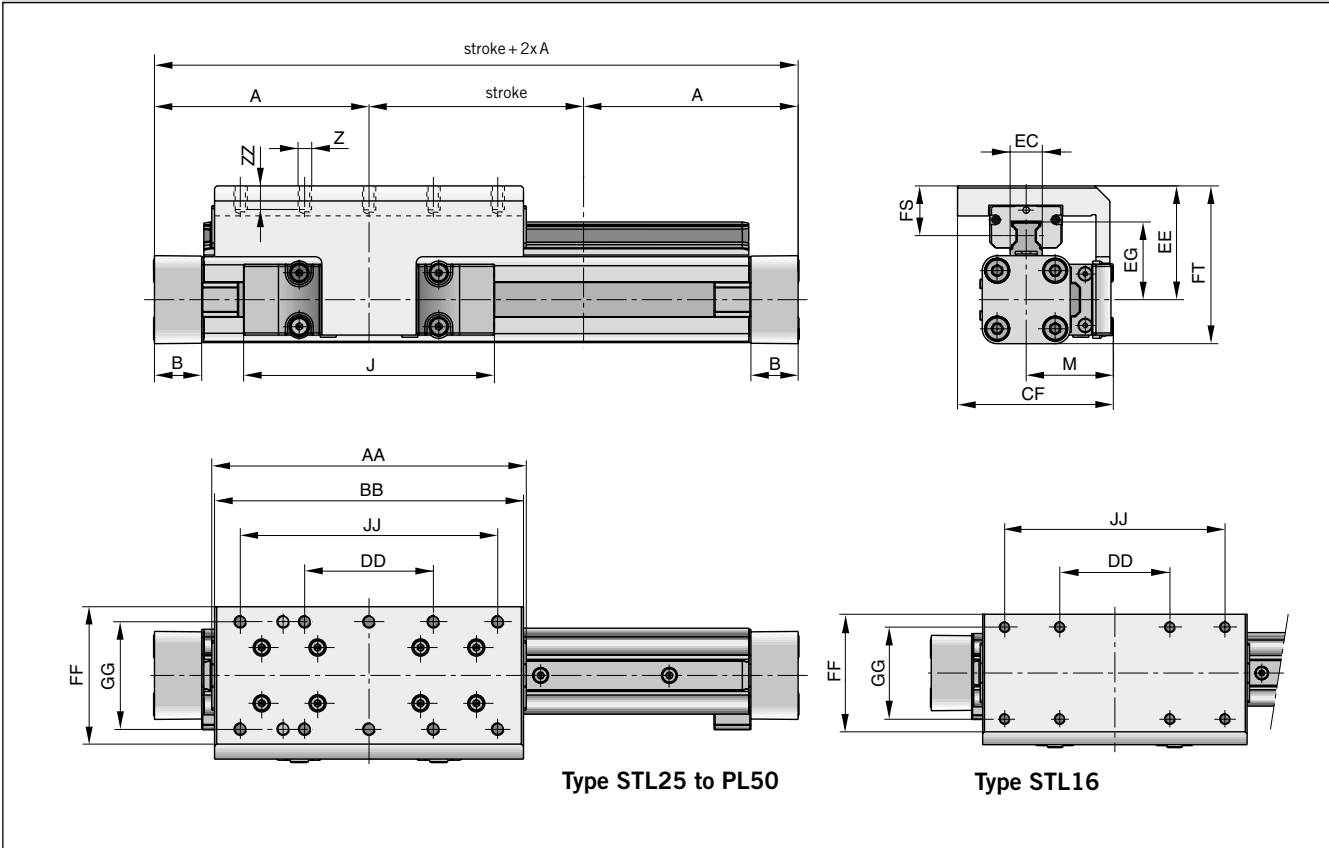

Dimension Table (mm) Series OSP-P STL16 to STL50

Series	A	B	J	M	Z	AA	BB	CF	DD	EC	EE	EG	FF	FS	FT	GG	JJ	ZZ
STL16	65	14	69	31	M4	93	90	55	30	15	40	24.6	48	18	55	36	70	8
STL25	100	22	117	40.5	M6	146.6	144	72.5	60	15	53	36.2	64	23.2	73.5	50	120	12
STL32	125	25.5	152	49	M6	186.6	184	91	80	15	62	42.2	84	26.2	88	64	160	12
STL40	150	28	152	55	M6	231	226	102	100	20	72	51.6	94	28.5	106.5	78	200	12
STL50	175	33	200	62	M6	270.9	266	117	120	23	85	62.3	110	32.5	128.5	90	240	16

Permissible Unsupported Length STL16 to STL50

Loading 1 – Top carrier

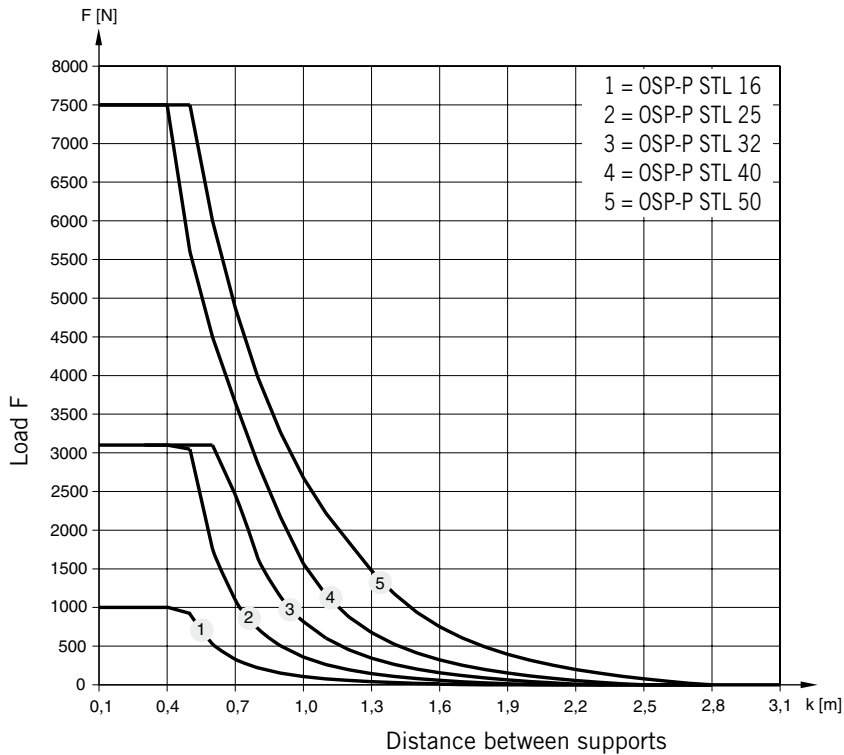

Permissible Unsupported Length STL16 to STL50

Loading 2 – Side carrier

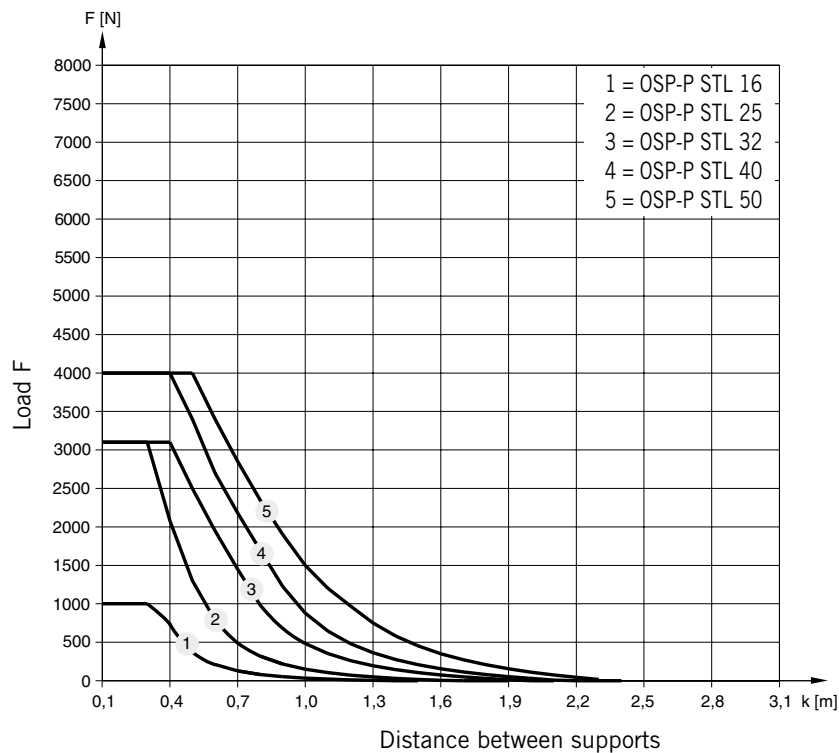

Mid-Section Support

(For versions, see P-1.45.005E-8, P1-.45.005E-9)

Mid-section supports are required from a certain stroke length to prevent excessive deflection and vibration of the linear drive. The diagrams show the maximum permissible unsupported length in relation to loading. A distinction must be drawn between loading 1 and loading 2. Deflection of 0.5 mm max. between supports is permissible.

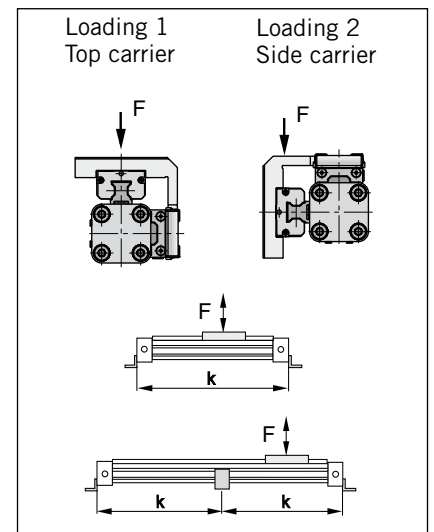

Note:

For speeds $v > 0.5$ m/s the distance between supports should not exceed 1 m.

Variable Stop

The variable stop Type VS provides simple stroke limitation.

It can be retrofitted and positioned anywhere along the stroke length. For every cylinder diameter two types of shock absorber are available – see „Shock Absorber Selection“ below.

Mid-section supports and magnetic switches can still be fitted on the same side as the variable stop.

Depending on the application, two variable stops can be fitted if required.

Variable Stop Type VS16 to VS50

Arrangement with two variable stops

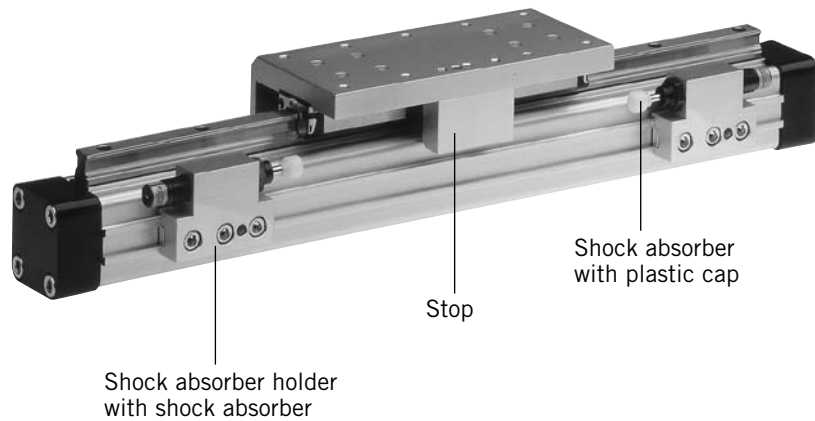

Shock Absorber Selection

The shock absorber is selected in dependence on the mass and speed.

The mass of the carrier itself must be taken into account.

Shock Absorber Selection in Dependence on Mass and Speed for Series OSP-STL16

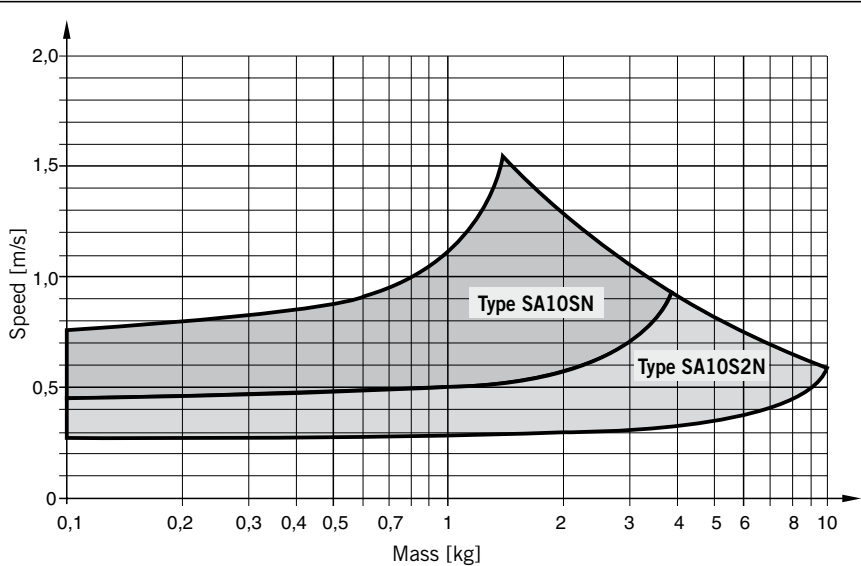

The values relate to an effective driving force of 78 N (6 bar)

Shock Absorber Selection in Dependence on Mass and Speed for Series OSP-STL25

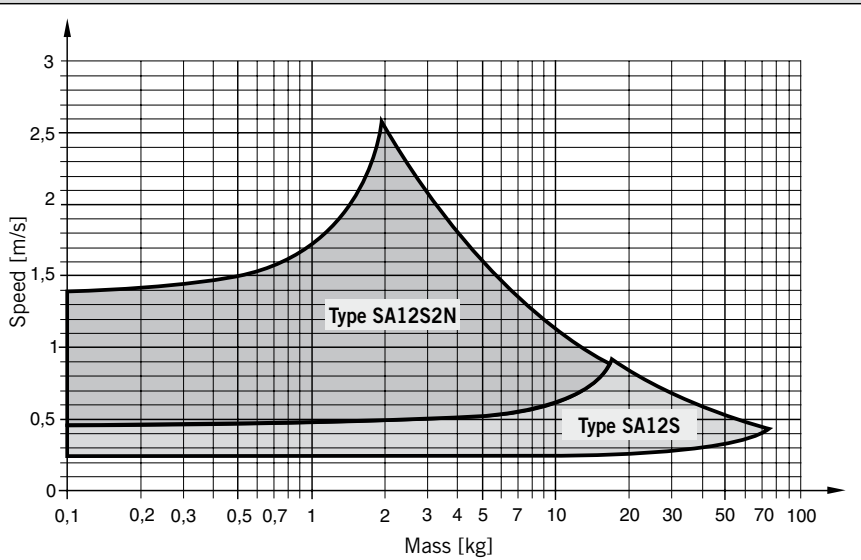

The values relate to an effective driving force of 250 N (6 bar)

Shock Absorber Selection in Dependence on Mass and Speed for Series OSP-STL32

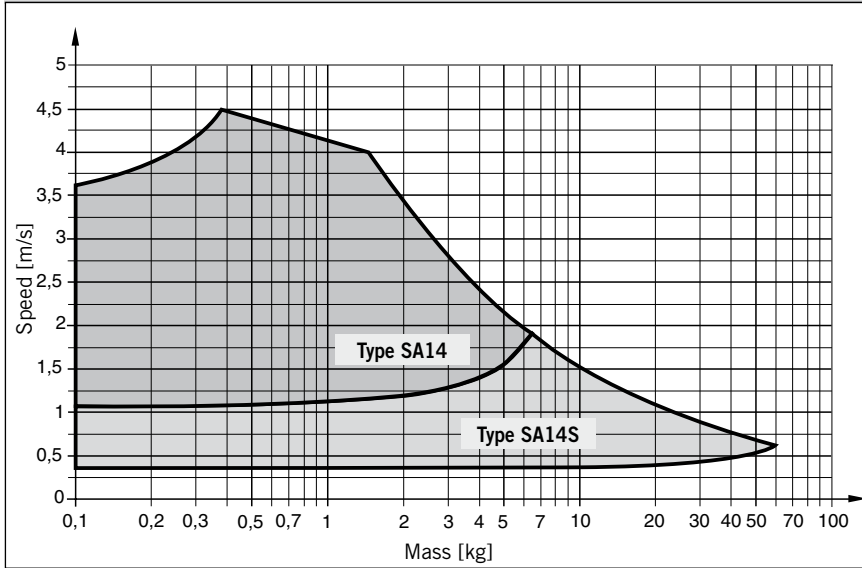

The values relate to an effective driving force of 420 N (6 bar)

Shock Absorber Selection in Dependence on Mass and Speed for Series OSP-STL40

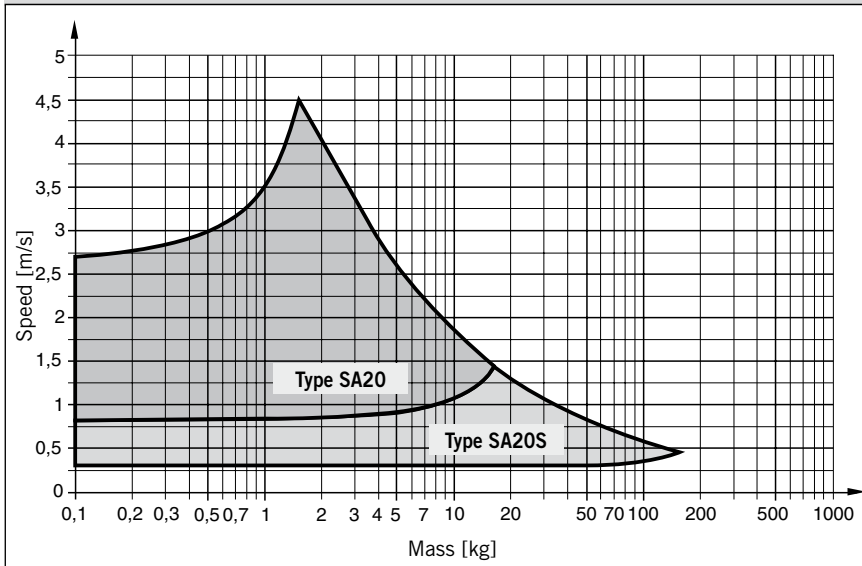

The values relate to an effective driving force of 640 N (6 bar)

Shock Absorber Selection in Dependence on Mass and Speed for Series OSP-STL50

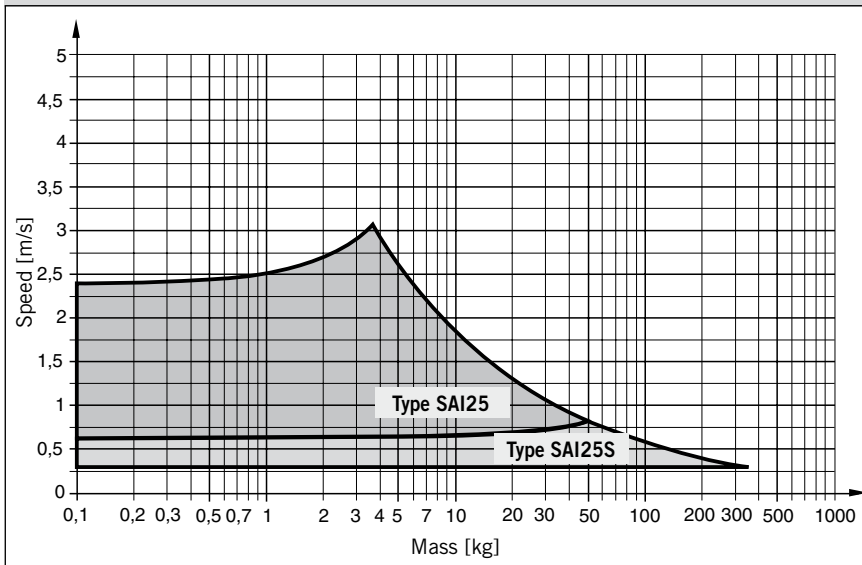

The values relate to an effective driving force of 1000 N (6 bar)

Dimensions – Variable Stop Type VS16 to VS50

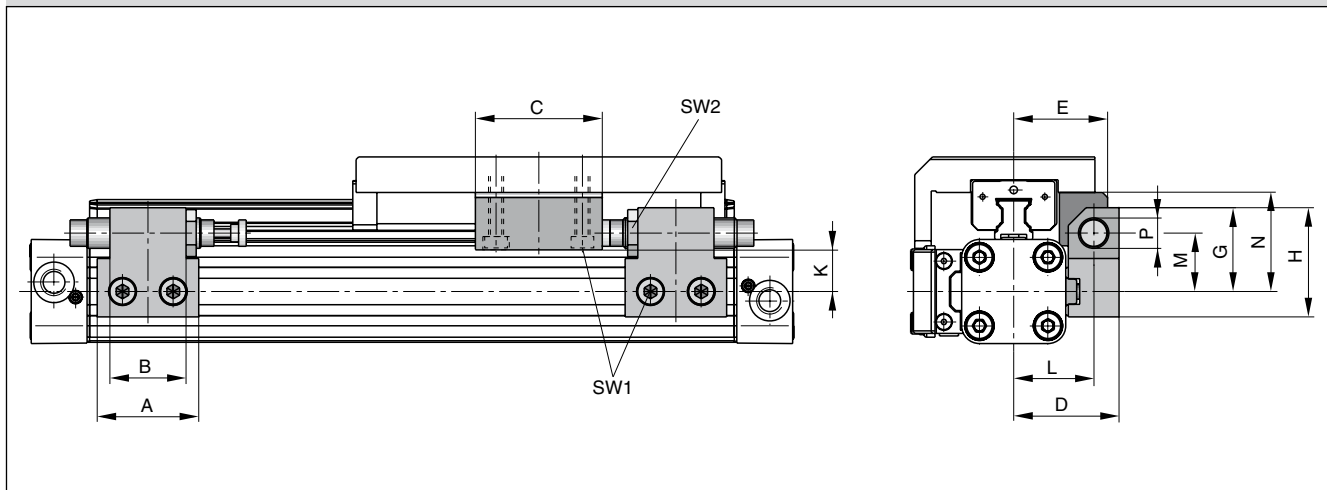

Dimension Table (mm) – Variable Stop Type VS16 to VS50

Series	Type	A	B	C	D	E	G	H	K	L	M	N	P	SW1	SW2
OSP-STL16	VS16	30	14	25	33	30	28	38	16.2	25.5	20.5	30	M10x1	4	12.5
OSP-STL25	VS25	40	30	50	41.5	37	33	43	18	31.5	23	39	M12x1	5	16
OSP-STL32	VS32	60	40	50	45.5	42	35	45	19	35.5	25	48	M14x1.5	5	17
OSP-STL40	VS40	84	52	60	64	59	48	63	25.6	50	34	58.6	M20x1.5	5	24
OSP-STL50	VS50	84	-	60	75	69	55	70	26.9	57	38	66.9	M25x1.5	5	30

Order Information – Variable Stop Type VS16 to VS50

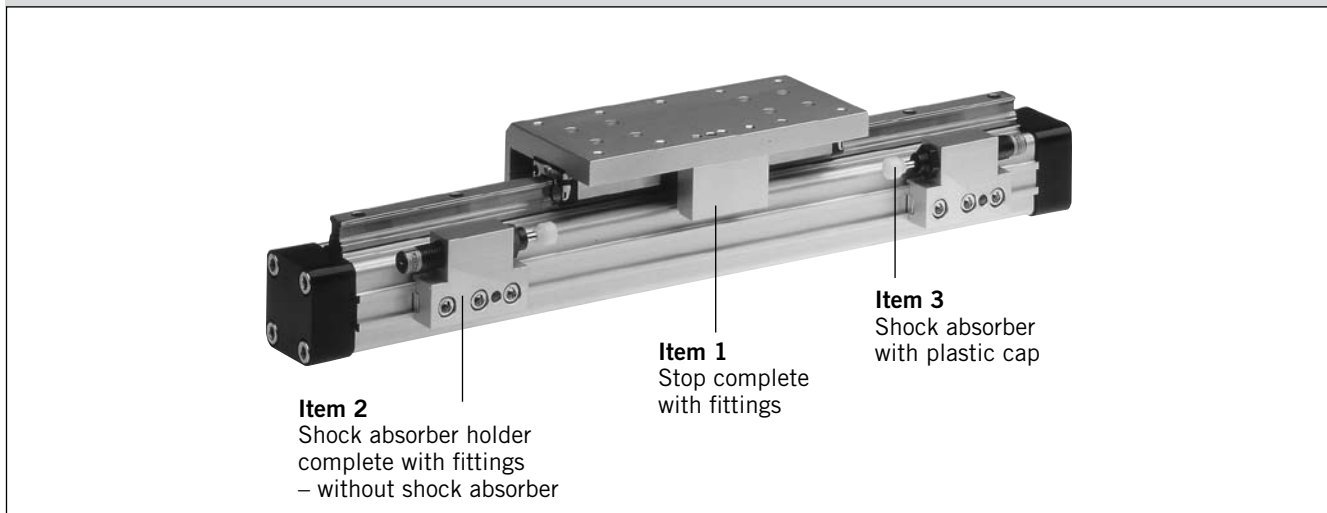

Order Instructions – Variable Stop Type VS16 to VS50

Item	Description	Size VS16		VS25		VS32		VS40		VS50	
		Type	Order No.	Type	Order No.	Type	Order No.	Type	Order No.	Type	Order No.
1	Stop, complete	-	21196	-	21197	-	21198	-	21199	-	21200
2	Shock absorber holder, complete	-	21201	-	21202	-	21203	-	21204	-	21205
3 *	Shock absorber, standard	SA10SN	7718	SA12S2N	7723	SA14	7708	SA20	7710	SAI25	7712
	Shock absorber, version S	SA10S2N	7721	SA12S	7707	SA14S	7709	SA20S	7711	SAI25S	7713

* Shock absorber with plastic cap

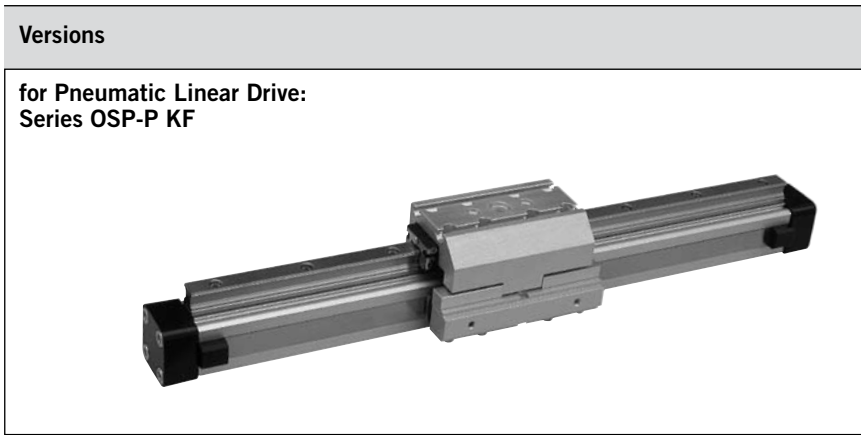

Recirculating Ball Bearing Guide KF



Series KF16 to KF50
For Linear Drives
Series OSP-P CLASSIC

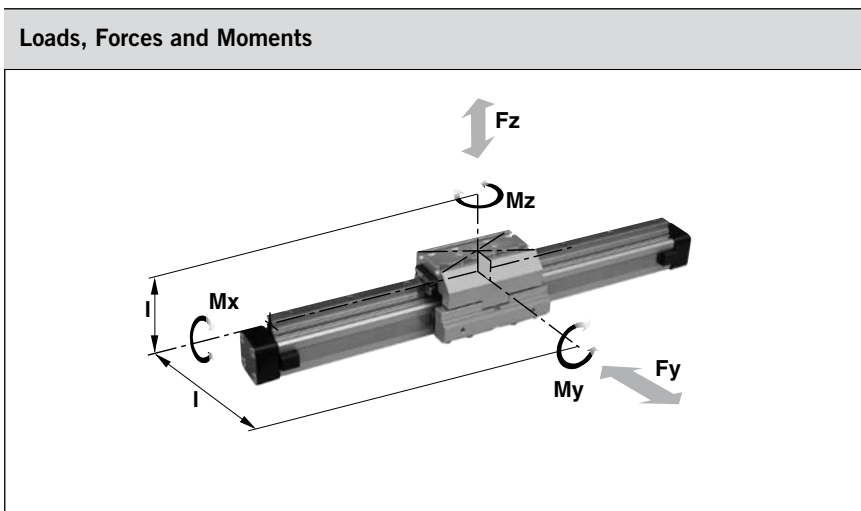

Features:

- Anodized aluminium guide carriage, the mounting dimensions correspond to FESTO Type: DGPL-KF
- Polished and hardened steel guide rail
- For high loads in all directions
- High precision
- Integrated wiper system
- Integrated grease nipples
- Any length of stroke up to 3700 mm
- Maximum speed
KF16, KF40: v = 3 m/s
KF25, KF32, KF50: v = 5 m/s

Technical Data

The table shows the maximum permissible loads. If multiple moments and forces act upon the cylinder simultaneously, the following equation applies:

$$\frac{M_x}{M_{x_{max}}} + \frac{M_y}{M_{y_{max}}} + \frac{M_z}{M_{z_{max}}} + \frac{F_y}{F_{y_{max}}} + \frac{F_z}{F_{z_{max}}} \leq 1$$

The sum of the loads should not exceed >1

The table shows the maximum permissible values for light, shock-free operation, which must not be exceeded even under dynamic conditions.

*** Please note:**
the mass of the carriage has to be added to the total moving mass when using the cushioning diagram.

Series	for Linear Drive	Max. Moments [Nm]			Max. Load [N]		Mass of drive with guide [kg]		Mass * guide carriage [kg]	Groove stone Thread Size	Order No.	
		Mx	My	Mz	Fy	Fz	with 0 mm stroke	increase per 100 mm stroke			Groove Stone	KF for OSP-P
KF16	OSP-P16	12	25	25	1000	1000	0.558	0.21	0.228	–	–	21101
KF25	OSP-P25	35	90	90	3100	3100	1.522	0.369	0.607	M5	13508	21102
KF32	OSP-P32	44	133	133	3100	3100	2.673	0.526	0.896	M5	13508	21103
KF40	OSP-P40	119	346	346	4000	7100	4.167	0.701	1.531	M6	13509	21104
KF50	OSP-P50	170	480	480	4000	7500	7.328	0.936	2.760	M8	13510	21105

For **linear drives** see P-1.10.002E
For **mountings** see P-1.45.005E

Dimensions Series OSP-P KF16 to KF50

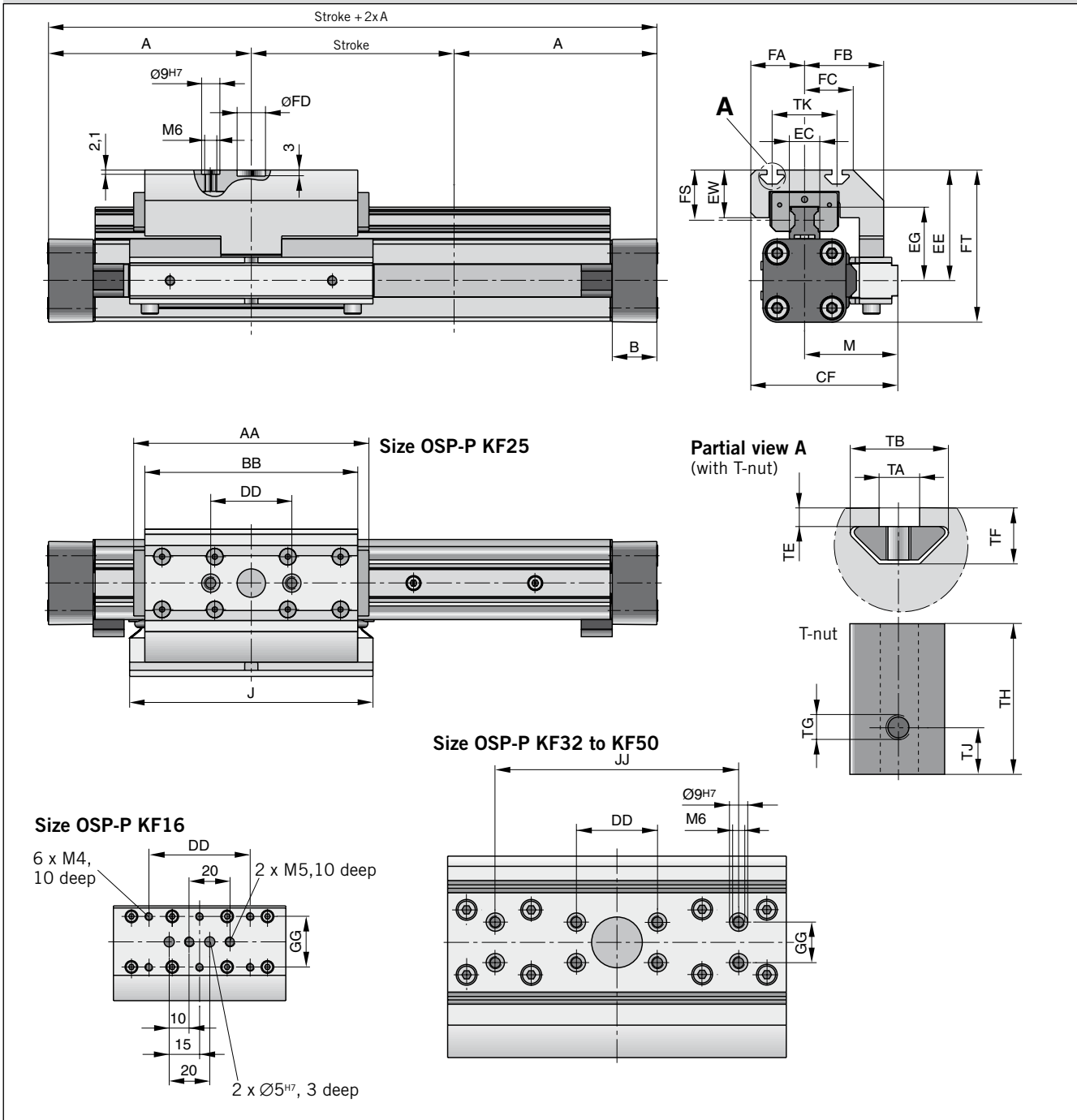

Dimension Table (mm) Series OSP-P KF16, KF25, KF32, KF40, KF50

Series	A	B	J	AA	BB	CF	DD	EC	EE	EG	EW	JJ	GG	M
KF16	65	14	76	93	85	48	50	15	41	24.6	10	–	25	30
KF25	100	22	120	120.2	105	72.5	40	15	54.5	36.2	23.5	–	–	46
KF32	125	25.5	160	146.2	131	93.8	40	15	60.5	42.2	23.5	–	20	59.8
KF40	150	28	150	188.5	167	103.3	40	20	69.5	51.6	26.5	120	20	60.8
KF50	175	33	180	220.2	202	121	40	23	90.5	62.3	32.5	120	40	69

Series	FA	FB	FC	FD	FT	FS	TA	TB	TE	TF	TG	TH	TJ	TK
KF16	17.7	29	16.5	–	56	19	–	–	–	–	–	–	–	–
KF25	26.5	39	24	14 ^{G7}	75	24.7	5	12.1	2.3	6.9	M5	11.5	4	32
KF32	34	53.8	34	25 ^{G7}	86.5	24.7	5	12.1	1.8	6.4	M5	11.5	4	47
KF40	42.5	56.8	41	25 ^{G7}	104	26	6	12.8	1.8	8.4	M6	17	5.5	55
KF50	52	65	50	25 ^{G7}	134	38	8	21.1	4.5	12.5	M8	23	7.5	72

Permissible Unsupported Length OSP-P KF16 to KF50

Loading 1 – Top carrier

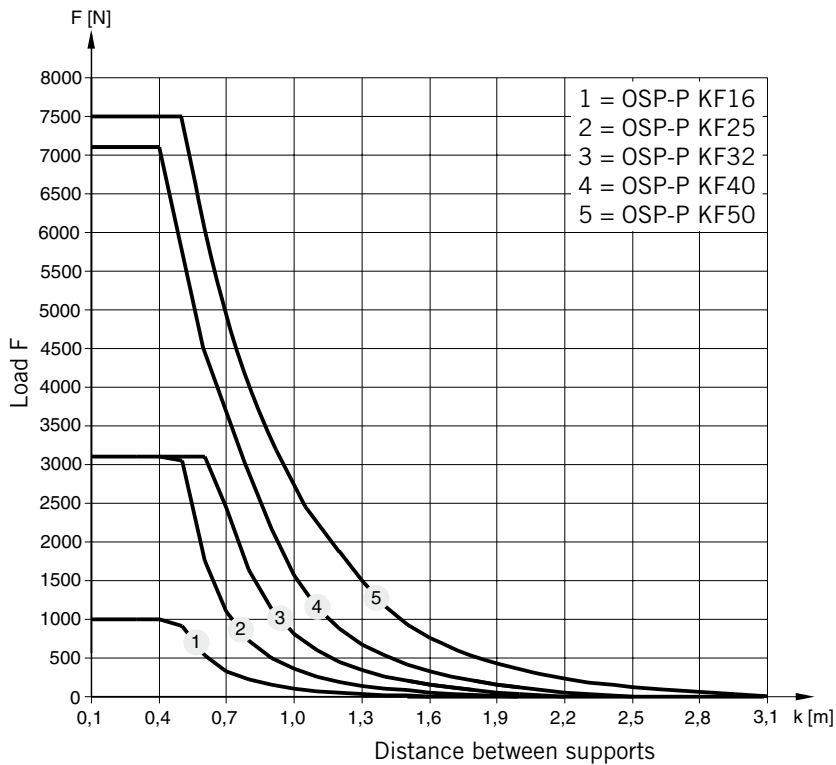

Permissible Unsupported Length OSP-P KF16 to KF50

Loading 2 – Side carrier

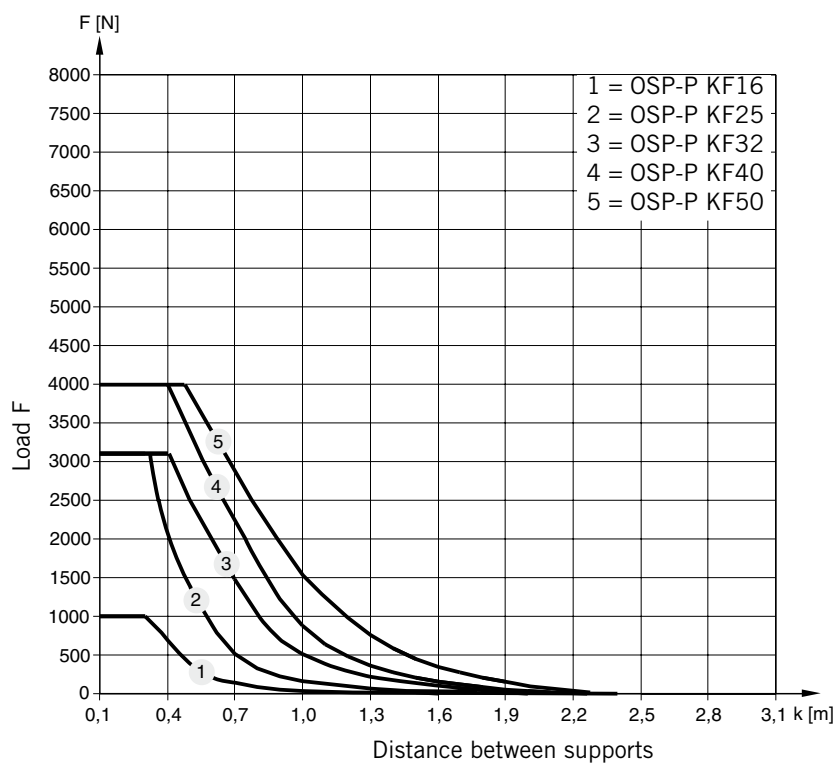

Mid-Section Support

(For versions, see P-1.45.005-5E, P1-.45.005E-8, P-1.45.005E-9)

Mid-section supports are required from a certain stroke length to prevent excessive deflection and vibration of the linear drive. The diagrams show the maximum permissible unsupported length in relation to loading. A distinction must be drawn between loading 1 and loading 2. Deflection of 0.5 mm max. between supports is permissible.

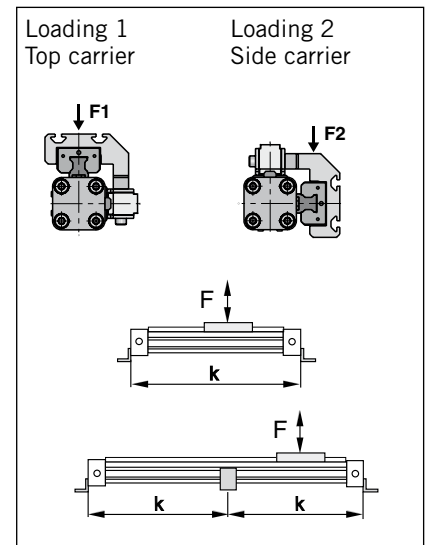

Note:

For speeds $v > 0.5$ m/s the distance between supports should not exceed 1 m.

Variable Stop

The variable stop Type VS provides simple stroke limitation. It can be retrofitted and positioned anywhere along the stroke length. For every cylinder diameter two types of shock absorber are available – see „Shock Absorber Selection“ below. Mid-section supports and magnetic switches can still be fitted on the same side as the variable stop. Depending on the application, two variable stops can be fitted if required.

Variable Stop Type VS16 to VS50

Arrangement with two variable stops

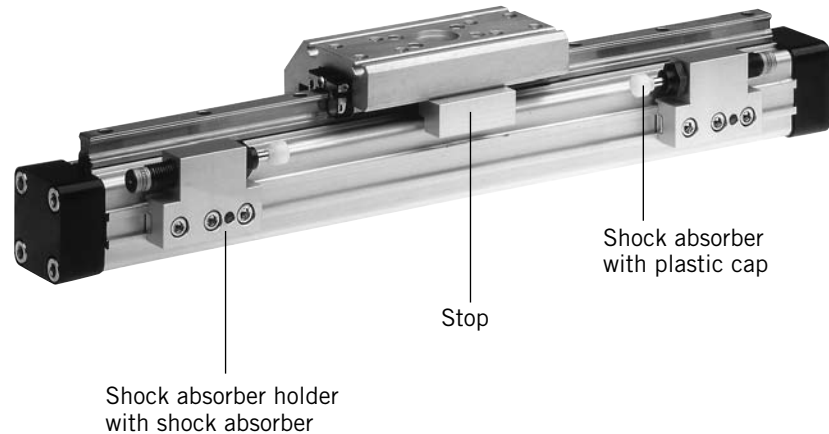

Shock Absorber Selection

The shock absorber is selected in dependence on the mass and speed. The mass of the carrier itself must be taken into account.

Shock Absorber Selection in Dependence on Mass and Speed for Series OSP-KF16

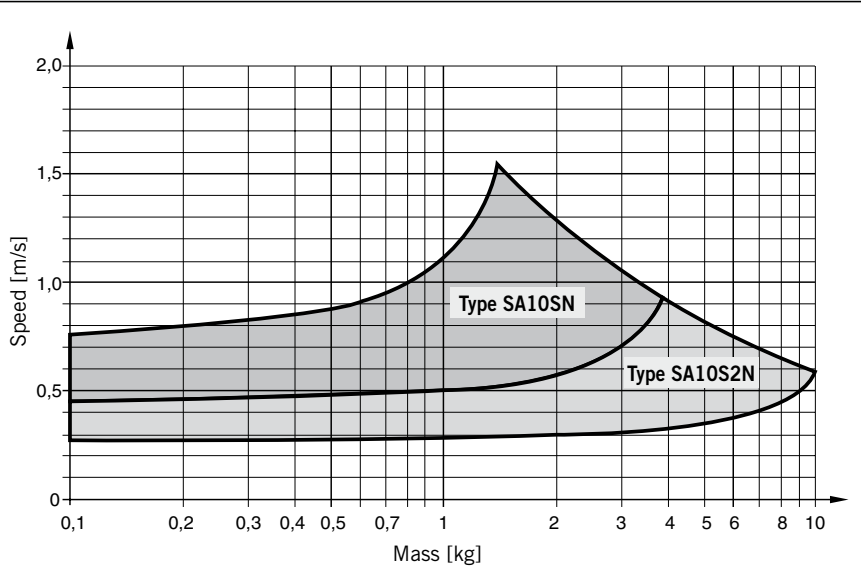

The values relate to an effective driving force of 78 N (6 bar)

Shock Absorber Selection in Dependence on Mass and Speed for Series OSP-KF25

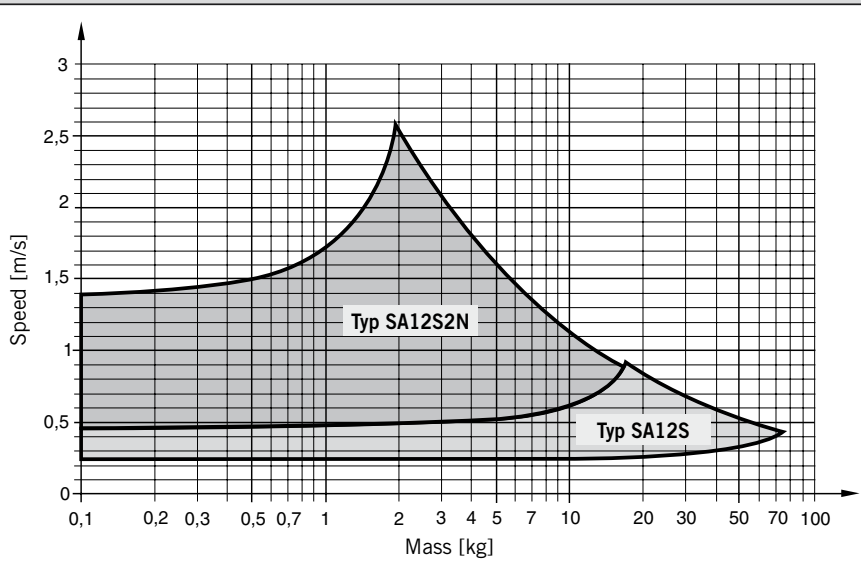

The values relate to an effective driving force of 250 N (6 bar)

Shock Absorber Selection in Dependence on Mass and Speed for Series OSP-KF32

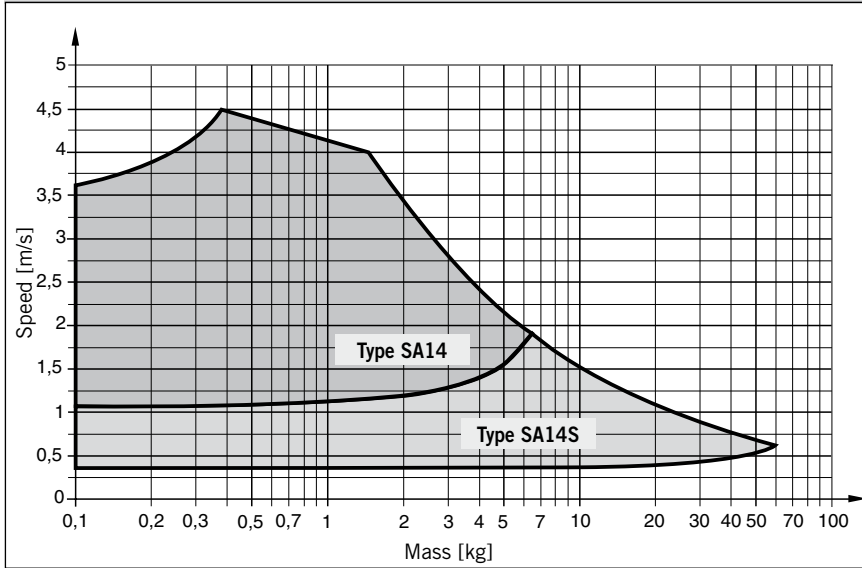

The values relate to an effective driving force of 420 N (6 bar)

Shock Absorber Selection in Dependence on Mass and Speed for Series OSP-KF40

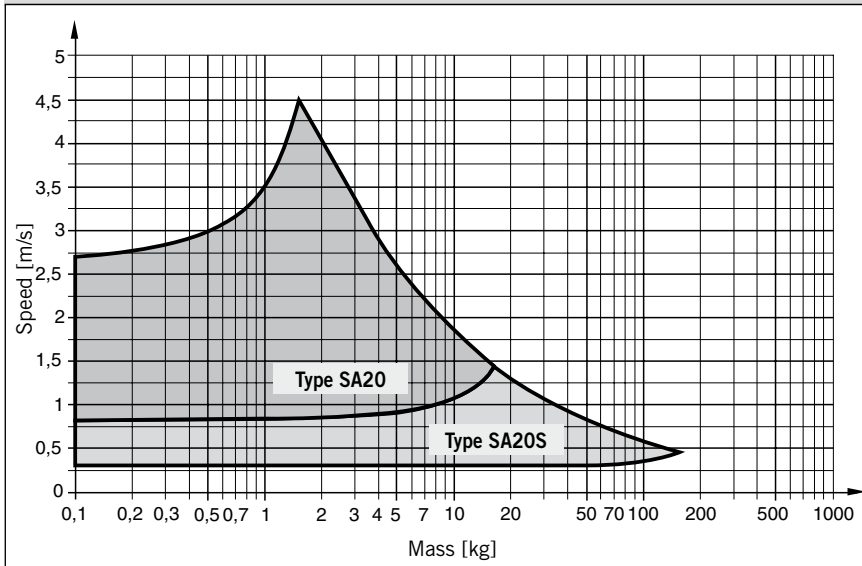

The values relate to an effective driving force of 640 N (6 bar)

Shock Absorber Selection in Dependence on Mass and Speed for Series OSP-KF50

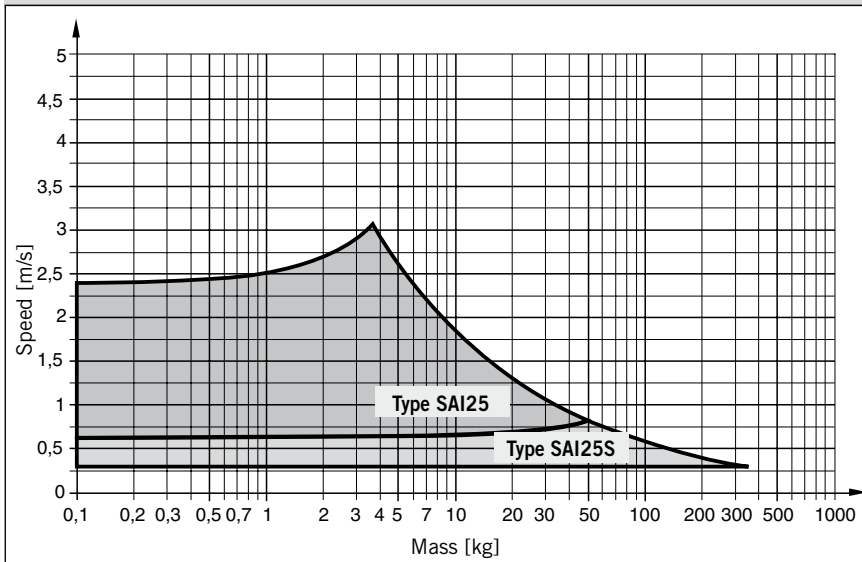

The values relate to an effective driving force of 1000 N (6 bar)

Dimensions – Variable Stop Type VS16 to VS50

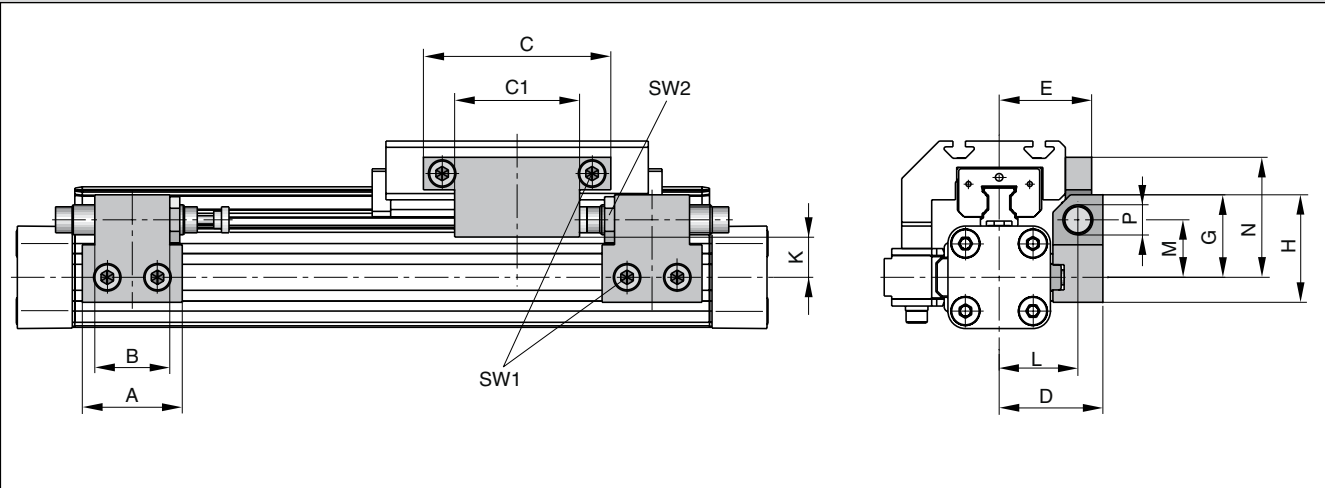

Dimension Table (mm) – Variable Stop Type VS16 to VS50

Series	Type	A	B	C	C1	D	E	G	H	K	L	M	N	P	SW1	SW2
OSP-KF16	VS16	30	14	50	25	33	29.7	28	38	16.2	25.5	20.5	40.5	M10 x 1	4	12.5
OSP-KF25	VS25	40	30	75	50	41.5	37	33	43	18	31.5	23	48	M12 x 1	5	16
OSP-KF32	VS32	60	40	50	-	45.5	41.5	35	45	19	35.5	25	37	M14 x 1.5	5	17
OSP-KF40	VS40	84	52	60	-	64	59	48	63	25.5	50	34	43	M20 x 1.5	5	24
OSP-KF50	VS50	84	-	60	-	75	69	55	70	26.9	57	38	58	M25 x 1.5	5	30

Order Information – Variable Stop Type VS16 to VS50

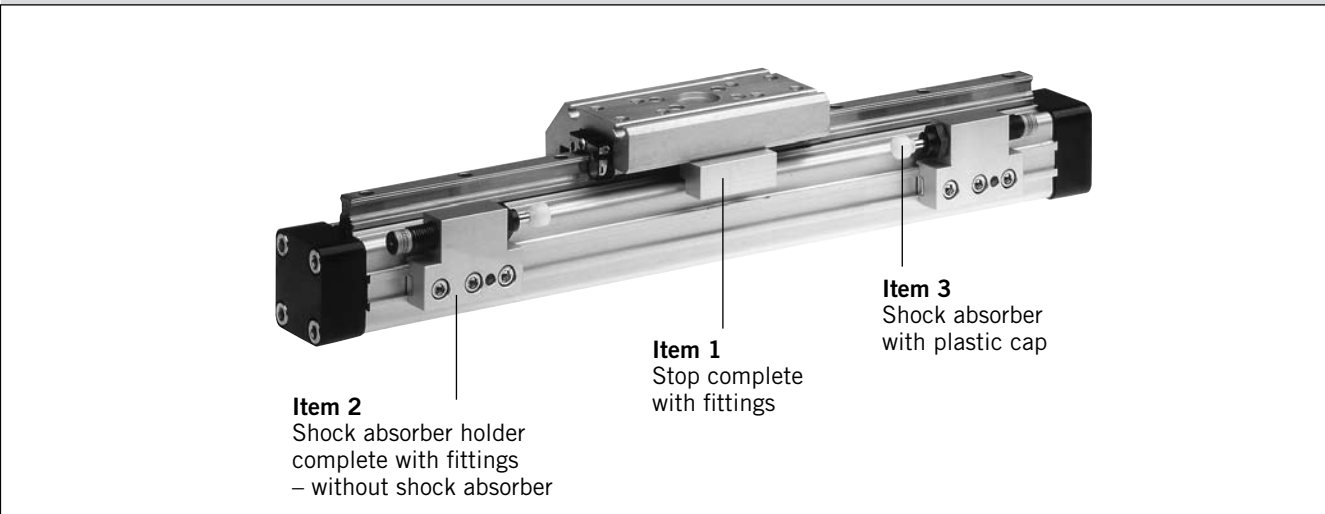

Order Instructions – Variable Stop Type VS16 to VS50

Item	Description	Size VS16		VS25		VS32		VS40		VS50	
		Type	Order No.	Type	Order No.	Type	Order No.	Type	Order No.	Type	Order No.
1	Stop, complete	-	21186	-	21187	-	21188	-	21189	-	21190
2	Shock absorber holder, complete	-	21201	-	21202	-	21203	-	21204	-	21205
3 *	Shock absorber, standard	SA10SN	7718	SA12S2N	7723	SA14	7708	SA20	7710	SAI25	7712
	Shock absorber, version S	SA10S2N	7721	SA12S	7707	SA14S	7709	SA20S	7711	SAI25S	7713

* Shock absorber with plastic cap

Version with pneumatic linear drive series OSP-P

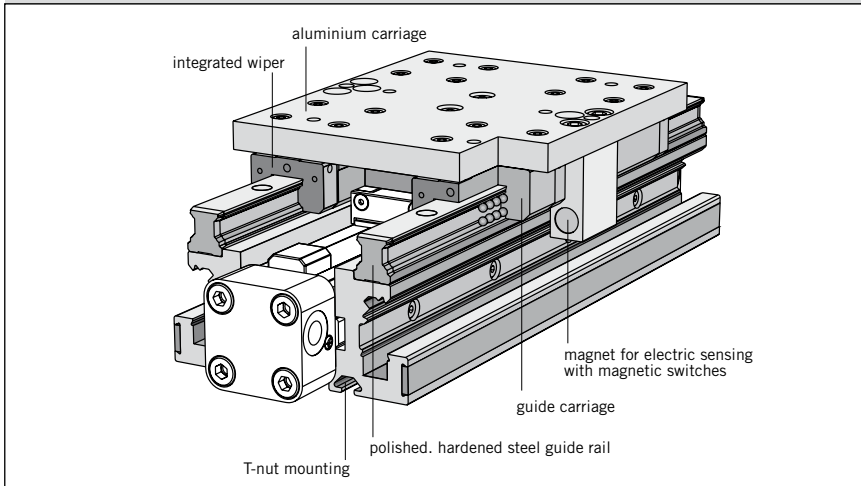

Heavy Duty-Guide HD



Series HD 25 to 50
for Linear Drive Series OSP-P

Loads. Forces and Moments

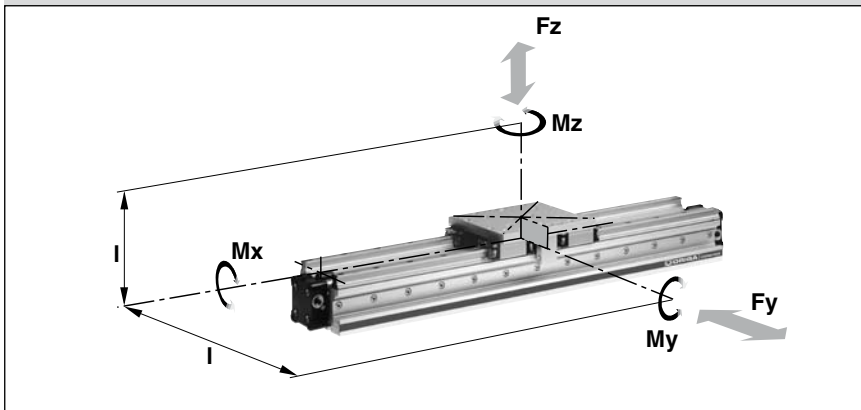

Features:

- Guide system: 4-row recirculating ball bearing guide
- Polished and hardened steel guide rail
- For highest loads in all directions
- Highest precision
- Integrated wiper system
- Integrated grease nipples
- Any lengths of stroke up to 3700 mm (longer strokes on request)
- Anodized aluminium guide carriage - dimensions compatible with OSP guide GUIDELINE
- Maximum speed $v = 5 \text{ m/s}$

Options:

- With variable stop
- With intermediate stop module

Technical Data

The table shows the maximum permissible loads. If multiple moments and forces act upon the cylinder simultaneously, the following equation applies:

$$\frac{M_x}{M_{x_{\max}}} + \frac{M_y}{M_{y_{\max}}} + \frac{M_z}{M_{z_{\max}}} + \frac{F_y}{F_{y_{\max}}} + \frac{F_z}{F_{z_{\max}}} \leq 1$$

The sum of the loads should not >1

The table shows the maximum permissible values for light, shock-free operation, which must not be exceeded even under dynamic conditions.

* Please note:

The mass of the carriage does not have to be added to the total moving mass when using the cushioning diagram.

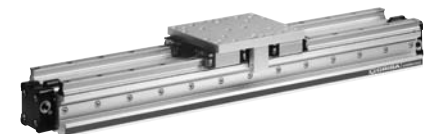

Series	for linear drive	Max. moments [Nm]			Max. loads [N]		Mass of the linear drive with guide [kg]		Mass * guide carriage [kg]	Order No. HDguide for OSP-P
		Mx	My	Mz	Fy	Fz	with 0 mm stroke	increase per 100 mm stroke		
HD 25	OSP-P25	260	320	320	6000	6000	3.065	0.924	1.289	21246
HD 32	OSP-P32	285	475	475	6000	6000	4.308	1.112	1.367	21247
HD 40	OSP-P40	800	1100	1100	15000	15000	7.901	1.748	2.712	21248
HD 50	OSP-P50	1100	1400	1400	18000	18000	11.648	2.180	3.551	21249

For linear drives see P-1.10.002E

P-A1P739E00EAE00X

The right to introduce technical modifications is reserved

Dimensions

Series OSP-P

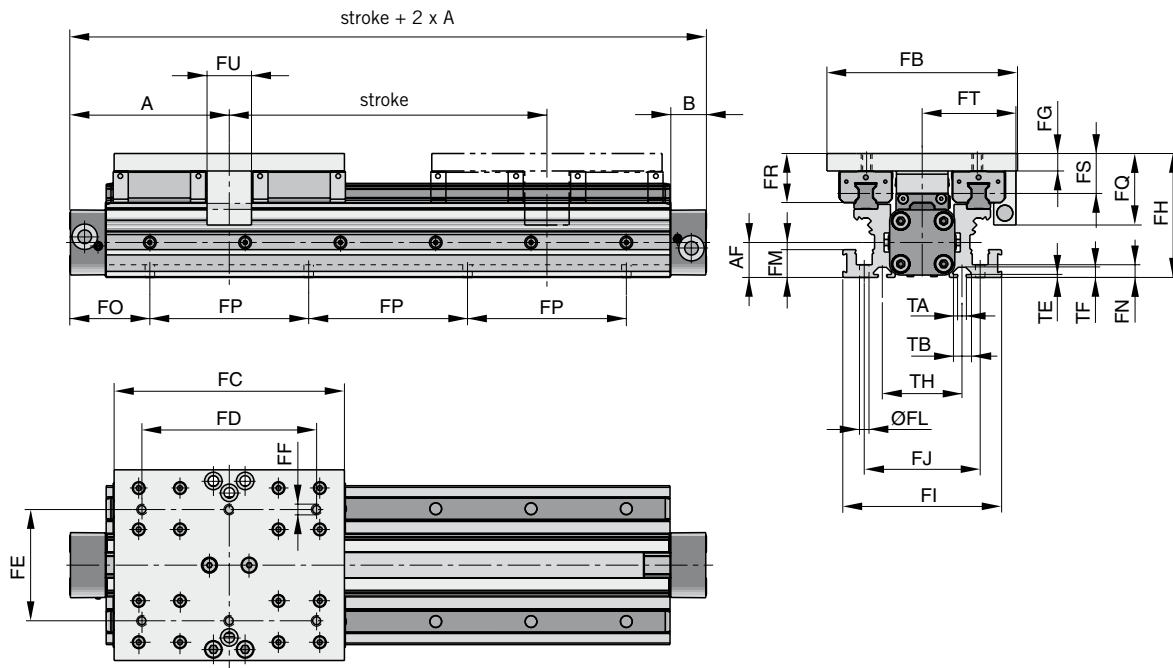

Note:

The HD heavy duty guide must be mounted on a flat surface for its entire length.

If T-grooves or T-bolts are used, the distance between them should not exceed 100 mm.

Variable Stop Type VS25 to VS50

The variable stop provides simple stroke limitation and can be supplied mounted on the right or left, as required.

For further information see following data sheets:

For dimensions and order instructions see P-1.40.008E-4

For shock absorber selection see P1-.40.006E-4, -5

Incremental displacement measuring system ORIGA-Sensoflex Series SFI-plus

can be supplied mounted on the right or left, as required.

For further information see data sheet P-1.50.002E

Arrangement of magnetic switches:

Magnetic switches can be fitted anywhere on either side.

For further information see following data sheets:

Magnetic Switches P-1.45.100E, P-1.45.104E and P-1.45.105E

Cable Cover P-1.45.102E-1

Linear Drives OSP-P P-1.10.002E

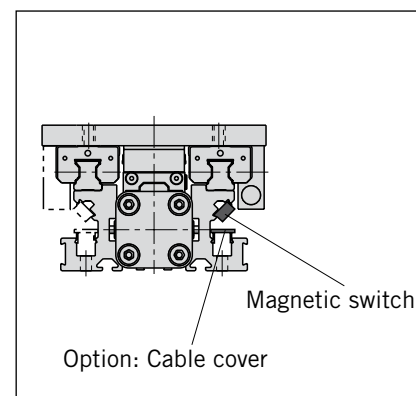
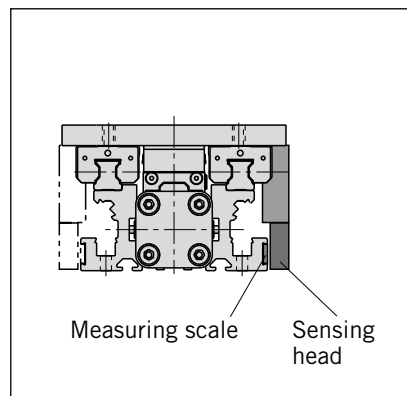
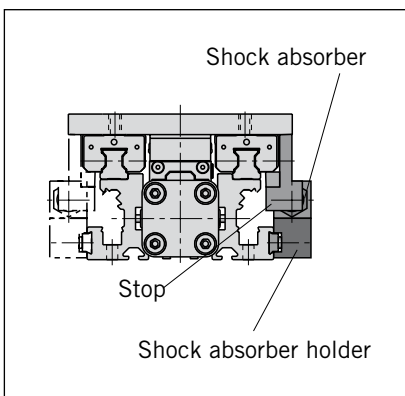

Dimension Table (mm)													
Series	A	B	AF	FB	FC	FD	FE	FF	FG	FH	FI	FJ	ØFL
HD25	100	22	22	120	145	110	70	M6	11	78	100	73	6
HD32	125	25.5	30	120	170	140	80	M6	11	86	112	85	6
HD40	150	28	38	160	180	140	110	M8	14	108	132	104	7.5
HD50	175	33	48	180	200	160	120	M8	14	118	150	118	7.5

Series	FM	FN	FP	FQ	FR	FS	FT	FU	TA	TB	TE	TF	TH
HD25	17.5	8	100	45	31	25	59	28	5.2	11.5	1.8	6.4	50
HD32	17.5	8	100	45	31	25	63	30	5.2	11.5	1.8	6.4	60
HD40	22	10	100	58	40	31.5	76	30	8.2	20	4.5	12.3	66
HD50	22	10	100	58	44	35.5	89	30	8.2	20	4.5	12.3	76

FO				
OSP-P				
x	HD25	HD32	HD40	HD50
00	50.0	75.0	50.0	75.0
01	50.5	75.5	50.5	75.5
02	51.0	76.0	51.0	76.0
03	51.5	76.5	51.5	76.5
04	52.0	77.0	52.0	77.0
05	52.5	77.5	52.5	77.5
06	53.0	78.0	53.0	78.0
07	53.5	78.5	53.5	78.5
08	54.0	79.0	54.0	79.0
09	54.5	79.5	54.5	79.5
10	55.0	80.0	55.0	80.0
11	55.5	80.5	55.5	80.5
12	56.0	81.0	56.0	81.0
13	56.5	81.5	56.5	81.5
14	57.0	82.0	57.0	82.0
15	57.5	82.5	57.5	82.5
16	58.0	83.0	58.0	83.0
17	58.5	83.5	58.5	83.5
18	59.0	84.0	59.0	84.0
19	59.5	84.5	59.5	84.5
20	60.0	85.0	60.0	85.0
21	60.5	85.5	60.5	85.5
22	61.0	86.0	61.0	86.0
23	61.5	86.5	61.5	86.5
24	62.0	87.0	62.0	87.0
25	62.5	87.5	62.5	87.5
26	63.0	88.0	63.0	88.0
27	63.5	88.5	63.5	88.5
28	64.0	89.0	64.0	89.0
29	64.5	89.5	64.5	89.5
30	65.0	90.0	65.0	90.0
31	65.5	90.5	65.5	90.5
32	66.0	91.0	66.0	91.0
33	66.5	91.5	66.5	91.5
34	67.0	92.0	67.0	92.0
35	67.5	92.5	67.5	92.5
36	68.0	93.0	68.0	93.0
37	68.5	93.5	68.5	93.5
38	69.0	94.0	69.0	94.0
39	69.5	94.5	69.5	94.5
40	70.0	95.0	70.0	95.0
41	70.5	95.5	70.5	95.5
42	71.0	96.0	71.0	96.0
43	71.5	96.5	71.5	96.5
44	72.0	97.0	72.0	97.0
45	72.5	97.5	72.5	97.5
46	73.0	98.0	73.0	98.0
47	73.5	98.5	73.5	98.5
48	74.0	99.0	74.0	99.0
49	74.5	99.5	74.5	99.5

FO				
OSP-P				
x	HD25	HD32	HD40	HD50
50	75.0	50.0	75.0	50.0
51	75.5	50.5	75.5	50.5
52	76.0	51.0	76.0	51.0
53	76.5	51.5	76.5	51.5
54	77.0	52.0	77.0	52.0
55	77.5	52.5	77.5	52.5
56	78.0	53.0	78.0	53.0
57	78.5	53.5	78.5	53.5
58	79.0	54.0	79.0	54.0
59	79.5	54.5	79.5	54.5
60	80.0	55.0	80.0	55.0
61	80.5	55.5	80.5	55.5
62	81.0	56.0	81.0	56.0
63	81.5	56.5	81.5	56.5
64	82.0	57.0	82.0	57.0
65	82.5	57.5	82.5	57.5
66	83.0	58.0	83.0	58.0
67	83.5	58.5	83.5	58.5
68	84.0	59.0	84.0	59.0
69	84.5	59.5	84.5	59.5
70	85.0	60.0	85.0	60.0
71	85.5	60.5	85.5	60.5
72	86.0	61.0	86.0	61.0
73	86.5	61.5	86.5	61.5
74	87.0	62.0	87.0	62.0
75	87.5	62.5	87.5	62.5
76	88.0	63.0	88.0	63.0
77	88.5	63.5	88.5	63.5
78	89.0	64.0	89.0	64.0
79	89.5	64.5	89.5	64.5
80	90.0	65.0	90.0	65.0
81	90.5	65.5	90.5	65.5
82	91.0	66.0	91.0	66.0
83	91.5	66.5	91.5	66.5
84	92.0	67.0	92.0	67.0
85	92.5	67.5	92.5	67.5
86	93.0	68.0	93.0	68.0
87	93.5	68.5	93.5	68.5
88	94.0	69.0	94.0	69.0
89	94.5	69.5	94.5	69.5
90	95.0	70.0	95.0	70.0
91	95.5	70.5	95.5	70.5
92	96.0	71.0	96.0	71.0
93	96.5	71.5	96.5	71.5
94	97.0	72.0	97.0	72.0
95	97.5	72.5	97.5	72.5
96	98.0	73.0	98.0	73.0
97	98.5	73.5	98.5	73.5
98	99.0	74.0	99.0	74.0
99	99.5	74.5	99.5	74.5

Note:

the dimension FO is derived from the last two digits of the stroke:

Example:

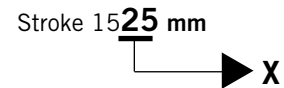

For a cylinder OSP-P25 the adjacent table indicates that for x = 25 mm: FO = 62.5 mm

Dimensions – Variable Stop Type VS25 to VS50

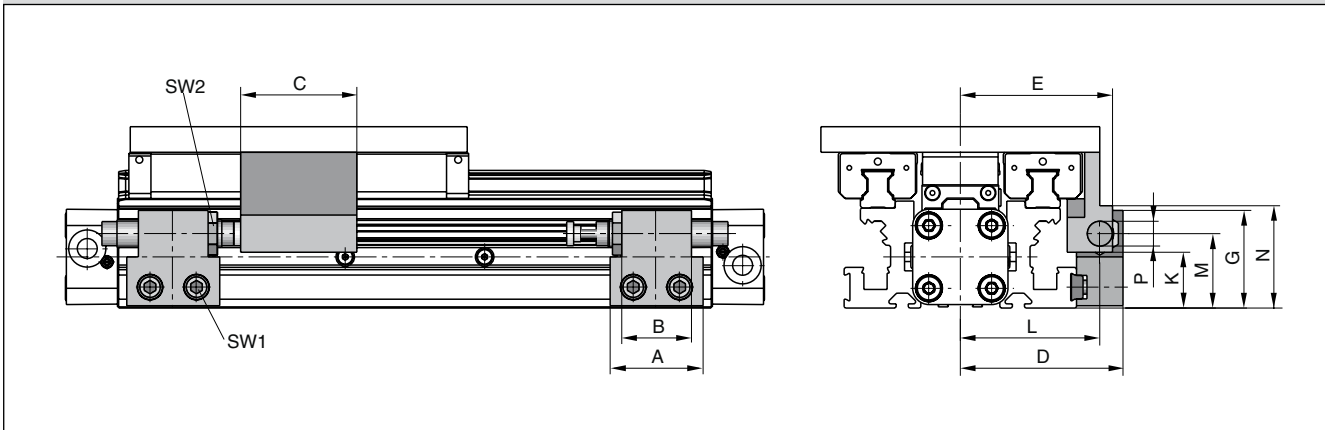

Dimension Table (mm) – Variable Stop Type VS25 to VS50

Series	Type	A	B	C	D	E	G	K	L	M	N	P	SW1	SW2
OSP-HD25	VS25	40	30	50	70	65.5	42	26	60	32	42	M12 x 1	5	16
OSP-HD32	VS32	60	40	54	73	71	44	28	63	34	53	M14 x 1.5	5	17
OSP-HD40	VS40	84	52	55	96	92	59	35	82	45	61	M20 x 1.5	5	24
OSP-HD50	VS50	84	-	60	107	105	66	37	89	49	66	M25 x 1.5	5	30

Order Information – Variable Stop Type VS25 to VS50

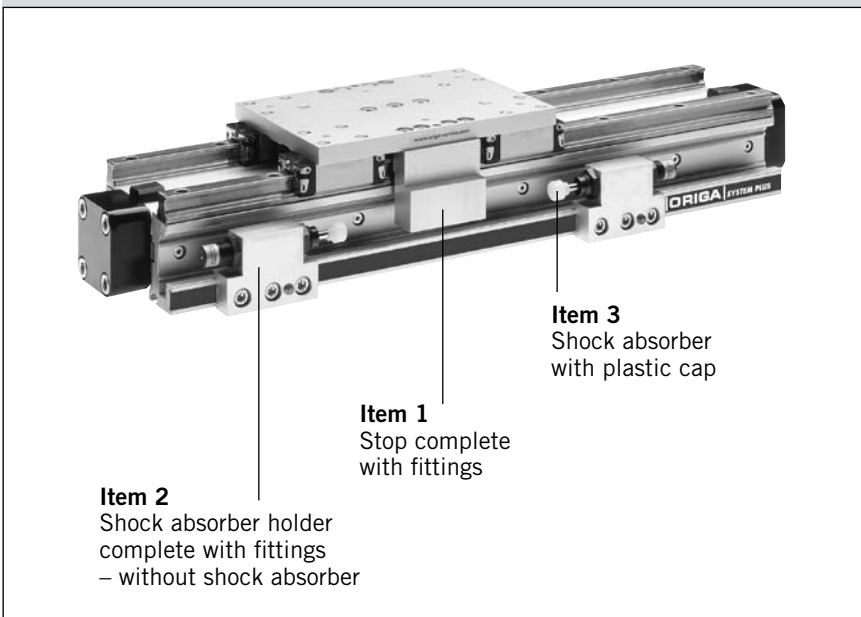

Shock Absorber Selection

For shock absorber selection in dependence on mass and speed see data sheet P-1.40.006E-4. -5

Order Instructions – Variable Stop Type VS25 to VS50

Item	Description	Size VS25		VS32		VS40		VS50	
		Type	Order No.	Type	Order No.	Type	Order No.	Type	Order No.
1	Stop, complete	-	21257	-	21258	-	21259	-	21260
2	Shock absorber holder, complete	-	21202	-	21203	-	21204	-	21205
3 *	Shock absorber, standard	SA12S2N	7723	SA14	7708	SA20	7710	SAI25	7712
	Shock absorber, version S	SA12S	7707	SA14S	7709	SA20S	7711	SAI25S	7713

* Shock absorber with plastic cap (see data sheet P-1.40.006E-4. -5)

Intermediate stop module Type ZSM..HD

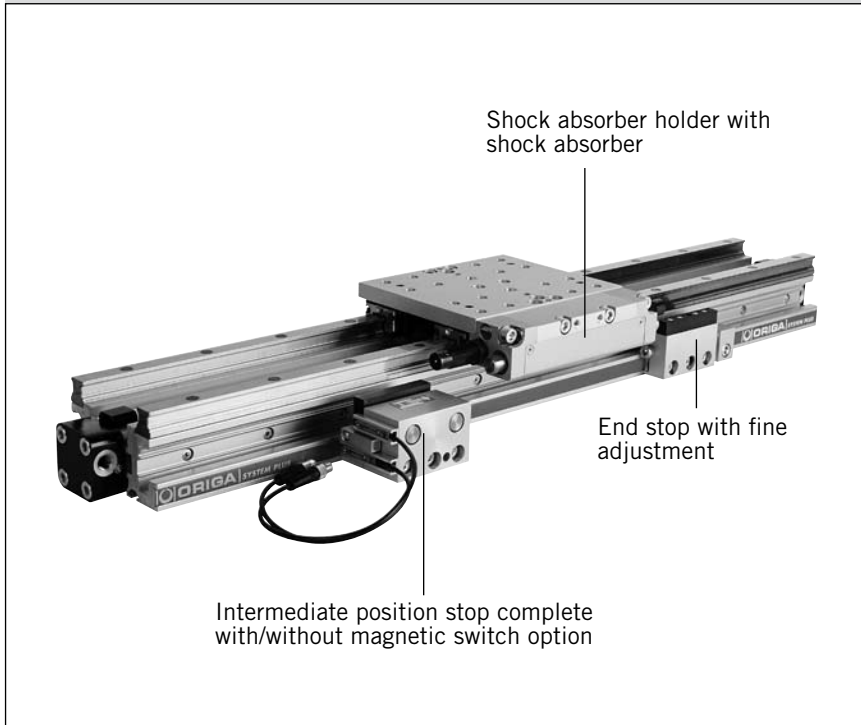

Intermediate stop module

The intermediate stop module ZSM allows the guide carriage to stop at any desired intermediate positions with high accuracy. It can be retrofitted. Depending on the application, i.e. the number of intermediate stops, one or more intermediate position stops can be used. The intermediate position stops can be retracted and extended without the need for the guide carriage to be moved back out of position. Therefore the guide carriage can be made to stop at the defined intermediate positions in any order.

ORIGA intermediate stop module ZSM:

- Allows stopping at any intermediate positions
- Intermediate position stops can be located steplessly anywhere along the whole stroke length
- Movement to the next position without reverse stroke
- Compact unit
- Cost-effective positioning module without electrical or electronic components
- Option: end stop with fine adjustment

Technical data

Temperature range	-10°C to +70°C
Operating pressure range	4 – 8 bar
Intermediate position grid	85 mm

Shock Absorber Type SA14S

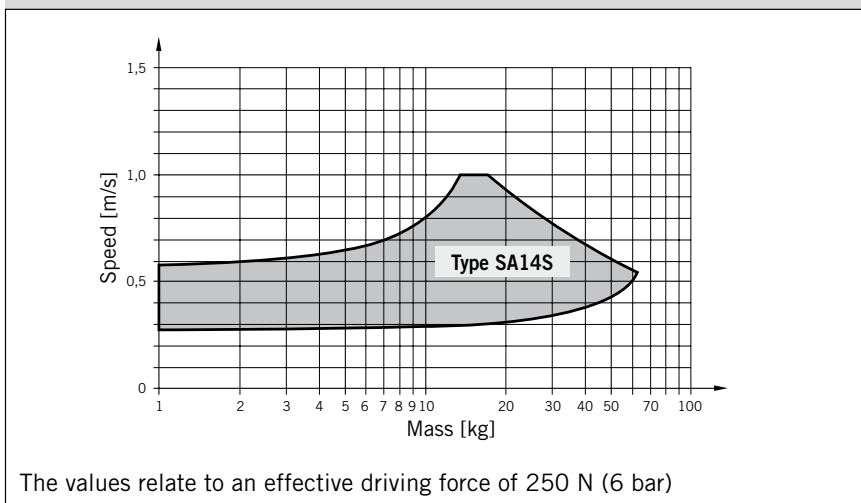

Dimensions – intermediate stop module Type ZSM..HD

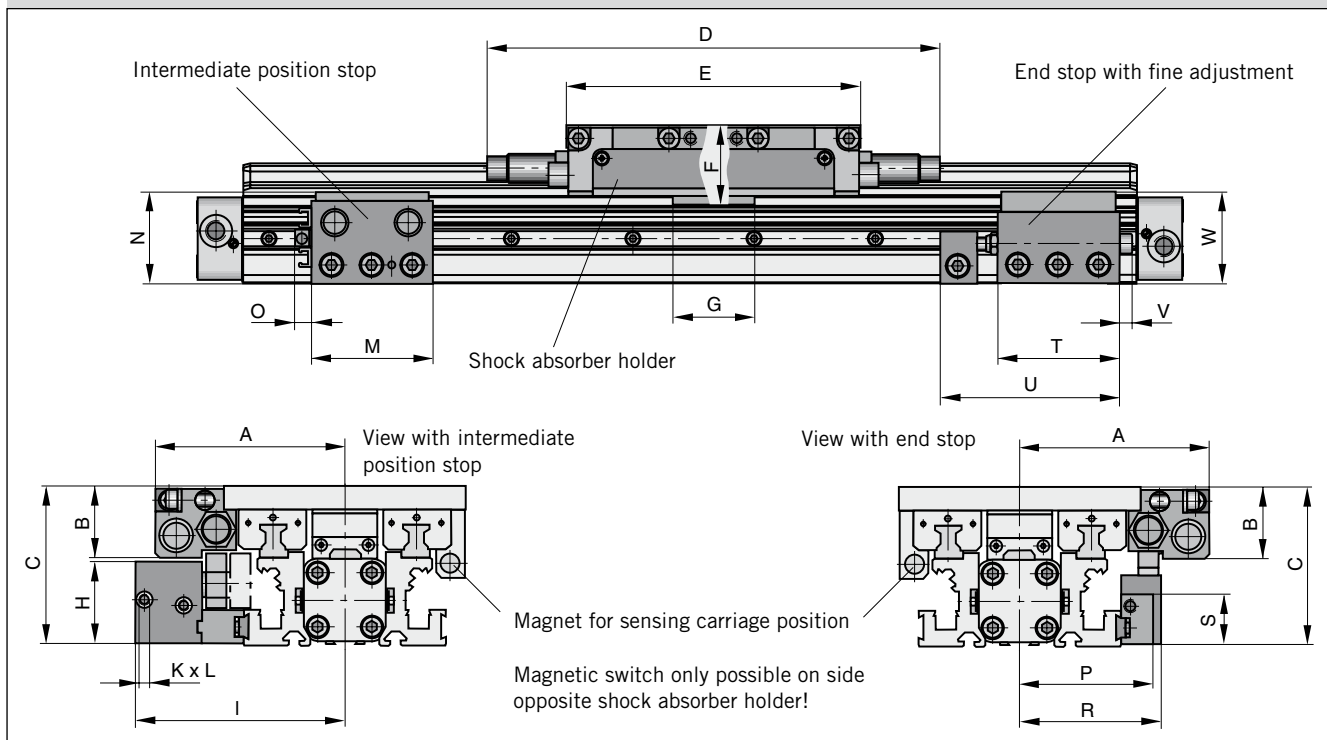

Dimension table (mm) – intermediate stop module Type ZSM..HD

Series	A	B	C	D	E	F	G	H	I	K	L	M	N	O	P	R	S	T	U	V	W
ZSM25	94	35	78	224	145	39	40	41	104	M5	5	60	45	8	66	70	26	60	93	6	45

Shock absorber arrangement in dependence on direction of movement

From right to left

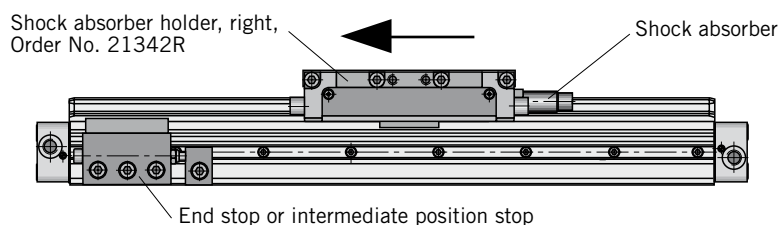

In both directions

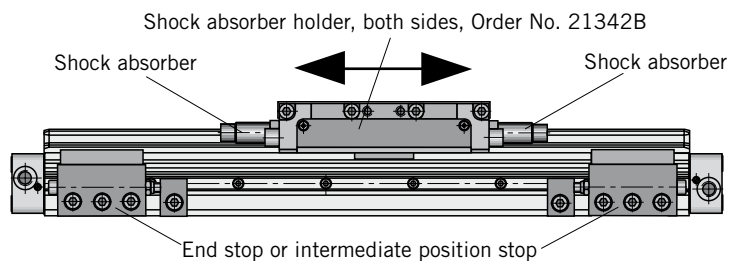

From left to right

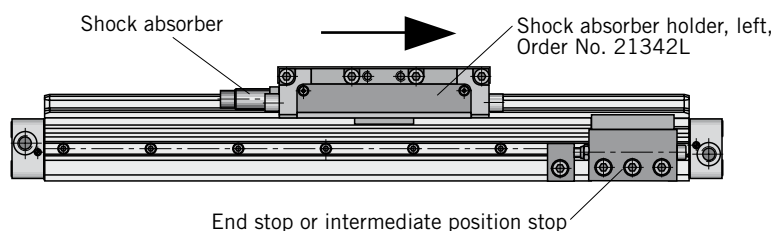

Order instructions – intermediate stop module Type ZSM..HD

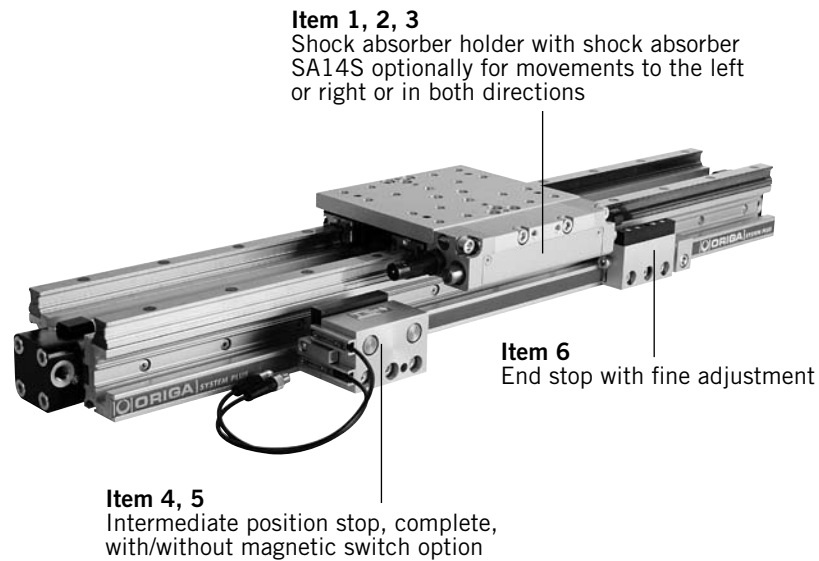

Illustration shows version with shock absorber holder for movement in both directions and magnetic switch option with T-slot switches (for magnetic switches see Accessories P-1.45.104E)

Order instructions – intermediate stop module Type ZSM..HD

Item	Description	For intermediate stop module	Order-No.
1*	Shock absorber holder with shock absorber SA14S, both sides	ZSM25HD	21342B
2*	Shock absorber holder with shock absorber SA14S, left	ZSM25HD	21342L
3*	Shock absorber holder with shock absorber SA14S, right	ZSM25HD	21342R
4	Intermediate position stop complete, without magnetic switch option	ZSM25HD	21343
5	Intermediate position stop complete, with magnetic switch option	ZSM25HD	21344
6	End stop with fine adjustment	ZSM25HD	21346

* The shock absorbers are installed in the shock absorber holder and adjusted in our workshop.

Note:

For movement onwards from the intermediate position, the intermediate position stop must advance.

The intermediate position stop can only advance if both cylinder chambers of the OSP-P cylinder are pressurized.

Active and Passive Brakes Series OSP-P



Contents

Description	Data Sheet No.	Page
Overview	P-1.42.001E	69-70
Standard cylinder with Active brake	P-1.42.002E	71-74
Plain bearing SLIDELINE with Active brake	P-1.40.002E	41-42
Aluminium roller guide PROLINE with Active brake	P-1.40.005E	47-48
Plain bearing SLIDELINE with Passive brake Multibrake	P-1.42.003E	75-78
Aluminium roller guide PROLINE with Passive brake Multibrake	P-1.42.004E	79-81

Active Brakes and Passive Brakes

Active Brake
for pneumatic linear drive
Series OSP-P
Piston diameters 25 - 80 mm.

See data sheet no. P-1.42.002E



Versions:

- ACTIVE Brake
- Plain bearing guide with integrated ACTIVE Brake
- Aluminium roller guide with integrated ACTIVE Brake
- Plain bearing guide with PASSIVE Brake
- Aluminium roller guide with PASSIVE Brake

Slideline with Active Brake
Plain bearing guide SLIDELINE - SL
with integrated ACTIVE Brake
Piston diameters 25 - 50 mm.

See data sheet no. P-1.40.002E



Proline with Active Brake
Aluminium roller guide
PROLINE - PL with
integrated ACTIVE Brake
Piston diameters 25 - 50 mm.

See data sheet no. P-1.40.005E



Multibrake with Slideline
MULTI BRAKE – PASSIVE Brake
with plainbearing guide
SLIDELINE - SL
Piston diameter 25 - 80 mm.

See data sheet no. P-1.42.003E

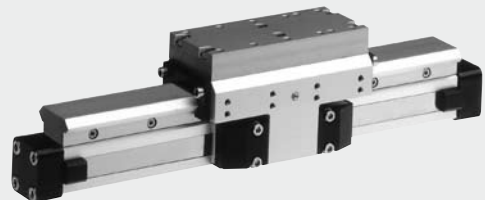

Multibrake with Proline
MULTI BRAKE – PASSIVE Brake with
aluminium roller guide
PROLINE - PL
Piston diameters 25 - 50 mm.

See data sheet no. P-1.42.004E

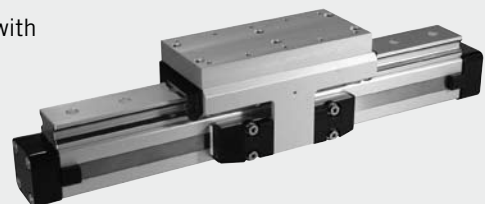

P-A1 P616E00HAA00X

The right to introduce technical modifications is reserved

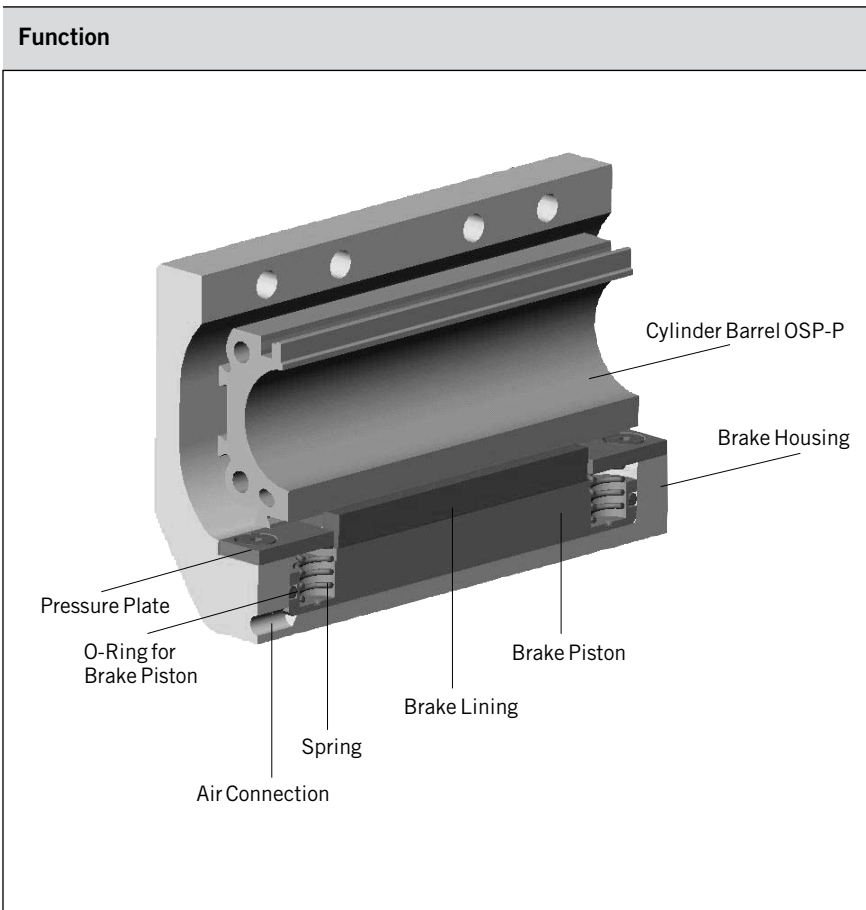

Active Brake



**Series AB 25 to 80
for linear drive**
• **Series OSP-P**

Features:

- Actuated by pressurisation
- Released by spring actuation
- Completely stainless version
- Holds position, even under changing load conditions

For further technical data, please refer to the data sheets for linear drives OSP-P (P-1.10.002E).

Note:

For combinations Active Brake AB + SFI-plus + Magnetic Switch contact our technical department please.

Forces and Weights

Series	For linear drive	Max. braking force [N] ⁽¹⁾	Brake pad way [mm]	Mass [kg]			Order No. Active brake
				Linear drive with brake 0 mm stroke	increase per 100mm stroke	brake*	
AB 25	OSP-P25	350	2.5	1.0	0.197	0.35	20806
AB 32	OSP-P32	590	2.5	2.02	0.354	0.58	20807
AB 40	OSP-P40	900	2.5	2.83	0.415	0.88	20808
AB 50	OSP-P50	1400	2.5	5.03	0.566	1.50	20809
AB 63	OSP-P63	2170	3.0	9.45	0.925	3.04	20810
AB 80	OSP-P80	4000	3.0	18.28	1.262	5.82	20811

⁽¹⁾ – at 6 bar
both chambers pressurised with 6 bar
Braking surface dry
– oil on the braking surface will reduce the braking force

*** Please Note:**
The mass of the brake has to be added to the total moving mass when using the cushioning diagram.

For additional information on loads, forces and moment, please refer to data sheet no. P-1.10.002E



Series OSP-P25 and P32 with Active Brake AB

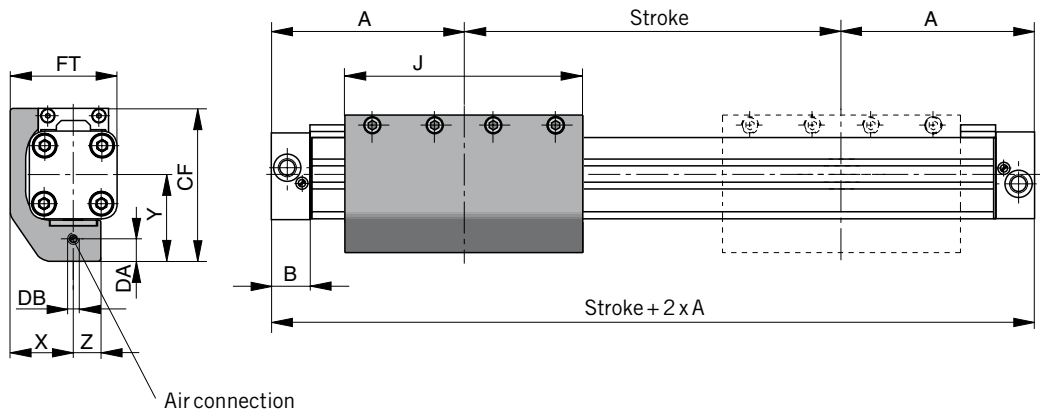

Series OSP-P40, P50, P63, P80 with Active Brake AB

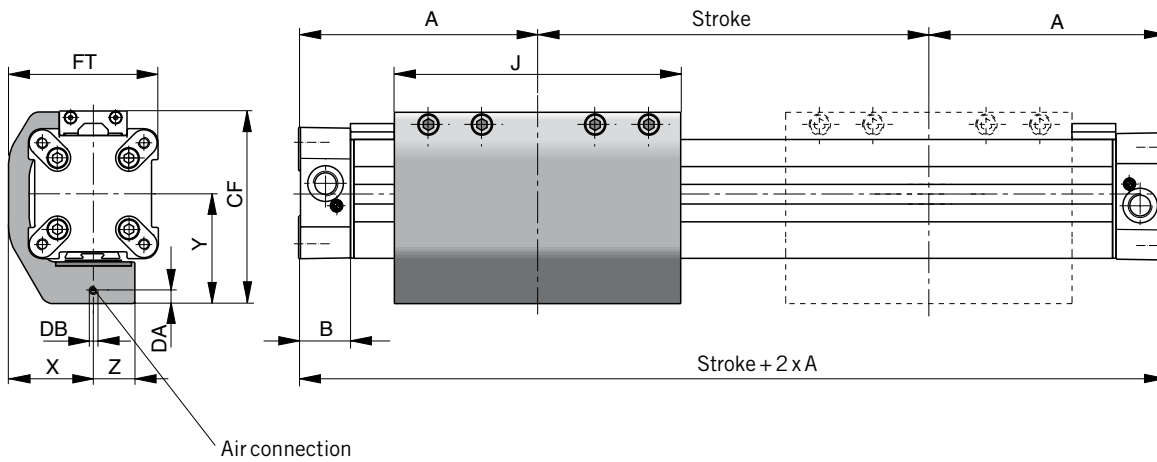

Dimension Table (mm)

Series	A	B	J	X	Y	Z	CF	DA	DB	FT
AB 25	100	22	117	29.5	43	13	74	4	M5	50
AB 32	125	25.5	151.4	36	50	15	88	4	M5	62
AB 40	150	28	151.4	45	58	22	102	7	M5	79.5
AB 50	175	33	200	54	69.5	23	118.5	7.5	M5	97.5
AB 63	215	38	256	67	88	28	151	9	G1/8	120
AB 80	260	47	348	83	105	32	185	10	G1/8	149

Series OSP – P25 and P32 with Active Brake AB: Type A3

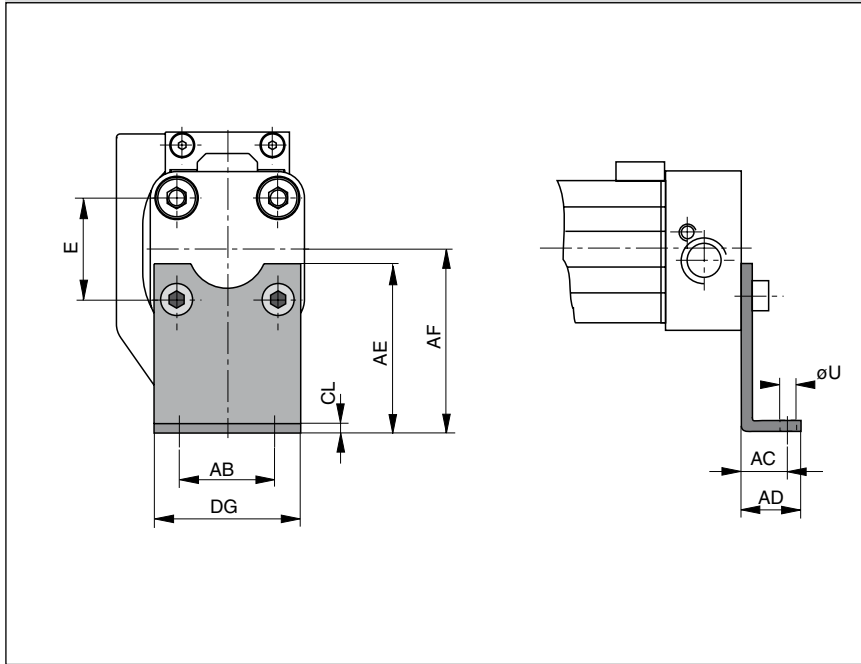

End Cap Mountings

On the end-face of each cylinder end cap there are four threaded holes for mounting the cylinder. The hole layout is square, so that the mounting can be fitted to the bottom, top or either side.

Material: Series OSP-P25, P32:
Galvanised steel

The mountings are supplied in pairs.



Series OSP – P40 , P50, P63, P80 with Active Brake AB: Type C3

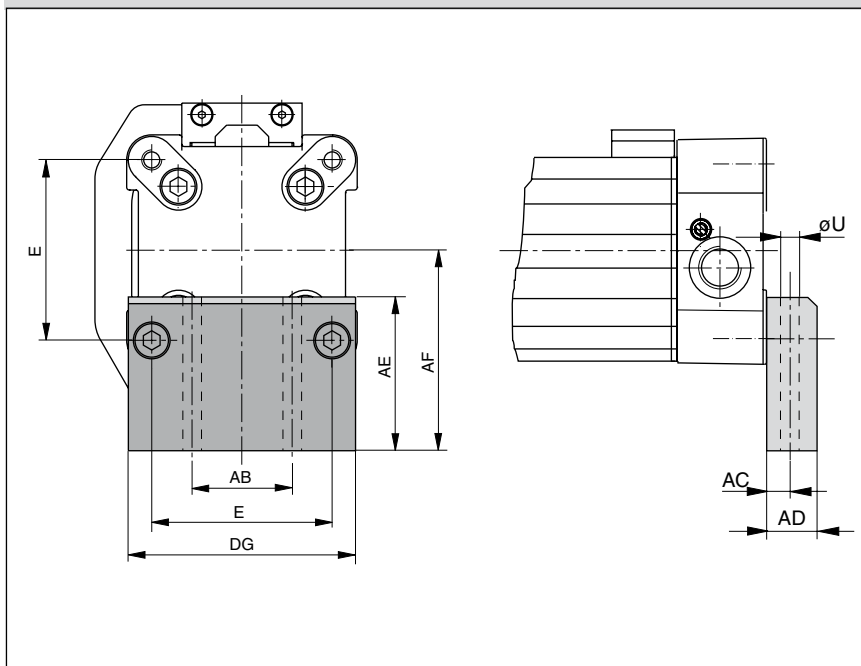

Material: Series OSP-P40,P50,
P63, P80:
Anodised aluminium

The mountings are supplied in pairs.

Stainless steel version on request.



Dimension Table (mm)

Series	E	øU	AB	AC	AD	AE	AF	CL	DG	Order No. Type A3	Type C3
AB 25	27	5.8	27	16	22	45	49	2.5	39	2060	–
AB 32	36	6.6	36	18	26	42	52	3	50	3060	–
AB 40	54	9	30	12.5	24	46	60	–	68	–	20339
AB 50	70	9	40	12.5	24	54	72	–	86	–	20350
AB 63	78	11	48	15	30	76	93	–	104	–	20821
AB 80	96	14	60	17.5	35	88	110	–	130	–	20822

Mid Section Support

Mid-section supports are required from a certain stroke length to prevent excessive deflection and vibration of the linear drive.

The diagrams show the maximum permissible unsupported length in relation to loading. Deflection of 0.5 mm max. between supports is permissible.

The mid section supports are attached to the dovetail rails, and can take axial loads.

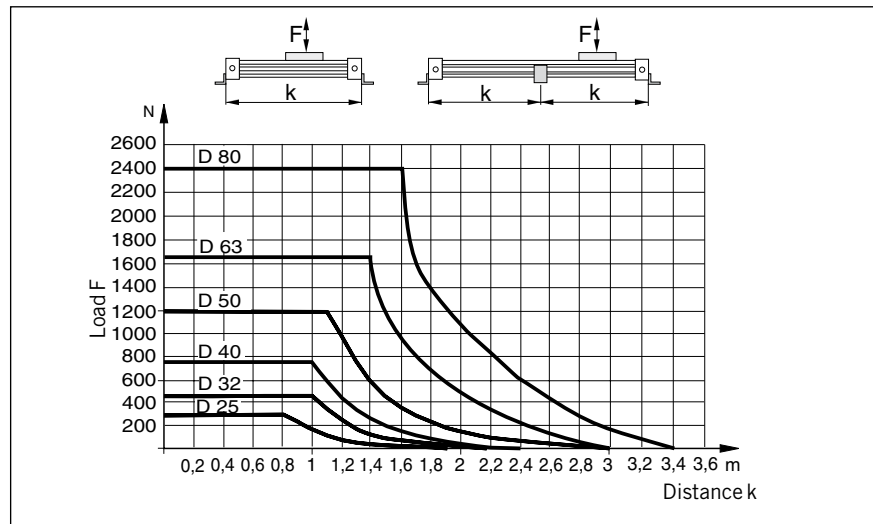

Mid Section Supports

Note to Type E3:

Mid section supports can only be mounted opposite of the brake housing.

Stainless steel version available on request.



Series OSP-P25 to P80 with Active Brake AB: Type E3 (Mounting from above / below with through-bolt)

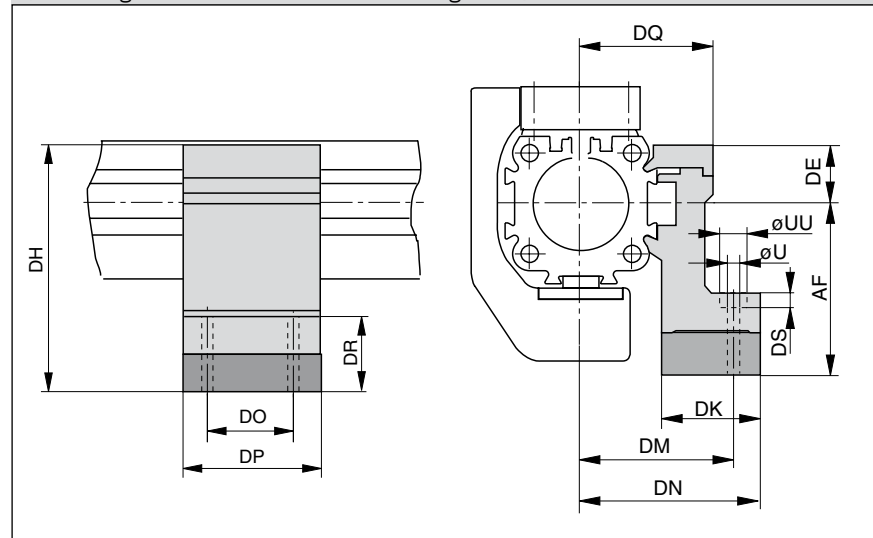

Dimension Table (mm)

Series	U	UU	AF	DE	DH	DK	DM	DN	DO	DP	DQ	DR	DS	Order No. Type E3
AB 25	5.5	10	49	16	65	26	40	47.5	36	50	34.5	35	5.7	20353
AB 32	5.5	10	52	16	68	27	46	54.5	36	50	40.5	32	5.7	20356
AB 40	7	-	60	23	83	34	53	60	45	60	45	32	-	20359
AB 50	7	-	72	23	95	34	59	67	45	60	52	31	-	20362
AB 63	9	-	93	34	127	44	73	83	45	65	63	48	-	20453
AB 80	11	-	110	39.5	149.5	63	97	112	55	80	81	53	-	20819

Accessories for linear drives with Active Brakes – please order separately

Description	For details information, see data sheet no.
Clevis mounting	P-1.45.002E
Adaptor profile	P-1.45.007E
T-groove profile	P-1.45.008E
Connection profile	P-1.45.009E
Magnetic switch (can only be mounted opposite of the brake housing)	P-1.45.100E, P-1.45.104E
Incremental displacement measuring system SFI-plus	P-1.50.002E

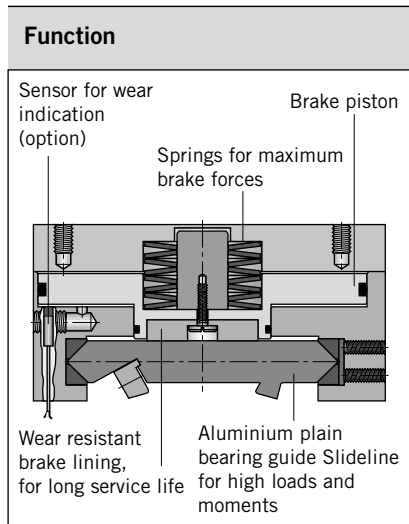
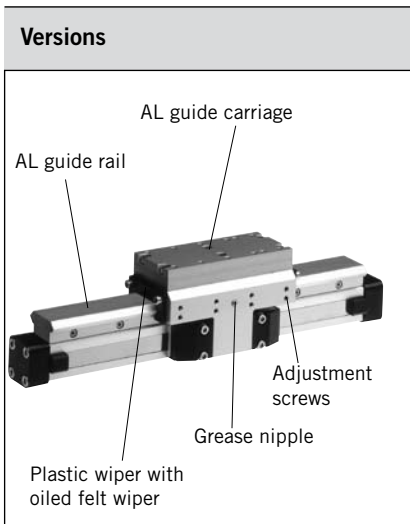

Multi-Brake Passive Brake with plain bearing guide Slideline SL



Series MB-SL 25 to 80
for Linear-drive
• Series OSP-P

Function:

The Multi-Brake is a passive device. When the air pressure is removed the brake is actuated and movement of the cylinder is blocked. The brake is released by pressurisation.

The high friction, wear resistant brake linings allow the Multi-Brake to be used as a dynamic brake to stop cylinder movement in the shortest possible time. The powerful springs also allow the Multi-Brake to be used effectively in positioning applications.

Features:

- Brake operated by spring actuation
- Brake release by pressurisation
- Optional sensor to indicate brake lining wear
- Anodised aluminium rail, with prism shaped slide elements
- Adjustable plastic slide elements
- Composite sealing system with plastic and felt wiper elements to remove dirt and lubricate the slideway
- Replenishable guide lubrication by integrated grease nipples
- Blocking function in case of pressure loss
- Intermediate stops possible

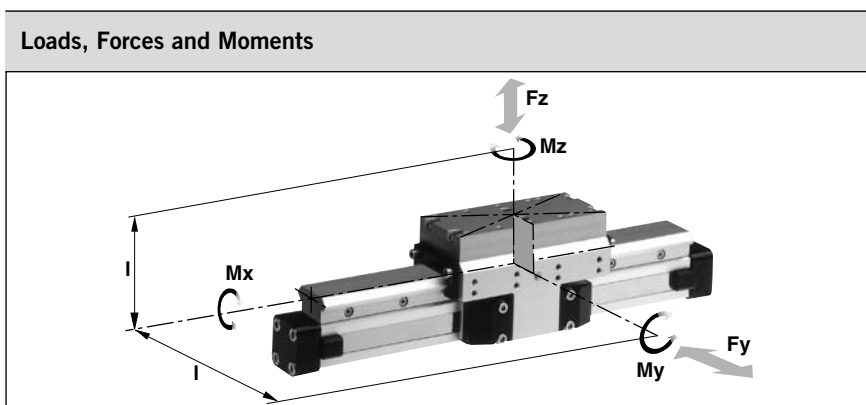

Technical Data:

The table shows the maximum values for light, shock-free operation, which must not be exceeded even in dynamic operation.

Load and moment data are based on speeds $v < 0.2$ m/s.

Operating pressure 4.5 - 8 bar
A pressure of 4.5 bar is required to release the brake.

For further technical information, please refer to the data sheets for linear drives OSP-P (P-1.10.002E)

¹⁾ Braking surface dry – oil on the braking surface will reduce the braking force

* **Please note:** in the cushioning diagram, the mass of the guide carriage has to be added to the total moving mass.

Series	For linear drive	Max. moments [Nm]			Max. loads [N] Ly, Lz	Max. brake force [N] ¹⁾	Mass of linear drive with guide [kg]		Mass* guide carriage [kg]	Order No. –MB-SL	
		Mx	My	Mz			with 0 mm stroke	increase per 100 mm stroke		without sensor	with sensor for wear indication
MB-SL 25	OSP-P25	14	34	34	675	470	2.04	0.39	1.10	20796	on request
MB-SL 32	OSP-P32	29	60	60	925	790	3.82	0.65	1.79	20797	on request
MB-SL 40	OSP-P40	50	110	110	1500	1200	5.16	0.78	2.34	20798	on request
MB-SL 50	OSP-P50	77	180	180	2000	1870	8.29	0.97	3.63	20799	on request
MB-SL 63	OSP-P63	120	260	260	2500	2900	13.31	1.47	4.97	20800	on request
MB-SL 80	OSP-P80	120	260	260	2500	2900	17.36	1.81	4.97	20846	on request

For linear drives see P-1.10.002E
For mountings see P-1.45.005E

Series OSP-P with Passive Brake MB-SL

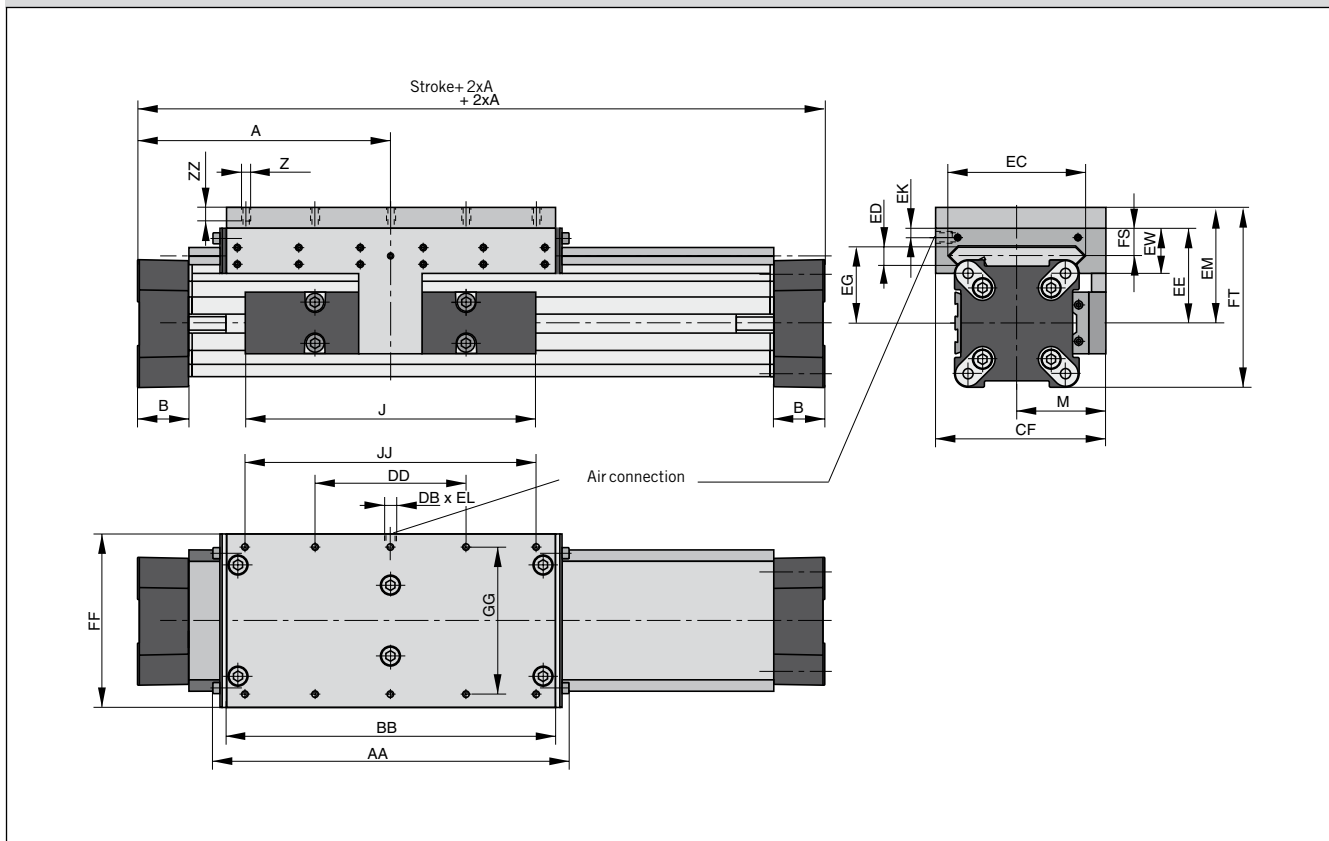

Dimension Table (mm)

Series	A	B	J	M	Z	AA	BB	DB	DD	CF	EC	ED	EE	EG	EK	EL	EM	EW	FF	FT	FS	GG	JJ	ZZ
MB-SL25	100	22	117	40,5	M6	162	142	M5	60	72.5	47	12	53	39	9	5	73	30	64	93.5	20	50	120	12
MB-SL32	125	25.5	152	49	M6	205	185	G1/8	80	91	67	14	62	48	7	10	82	33	84	108	21	64	160	12
MB-SL40	150	28	152	55	M6	240	220	G1/8	100	102	77	14	64	50	6.5	10	84	34	94	118.5	21.5	78	200	12
MB-SL50	175	33	200	62	M6	284	264	G1/8	120	117	94	14	75	56	10	12	95	39	110	138.5	26	90	240	12
MB-SL63	215	38	256	79	M8	312	292	G1/8	130	152	116	18	86	66	11	12	106	46	152	159	29	120	260	13
MB-SL80	260	47	348	96	M8	312	292	G1/8	130	169	116	18	99	79	11	12	119	46	152	185	29	120	260	13

Loading

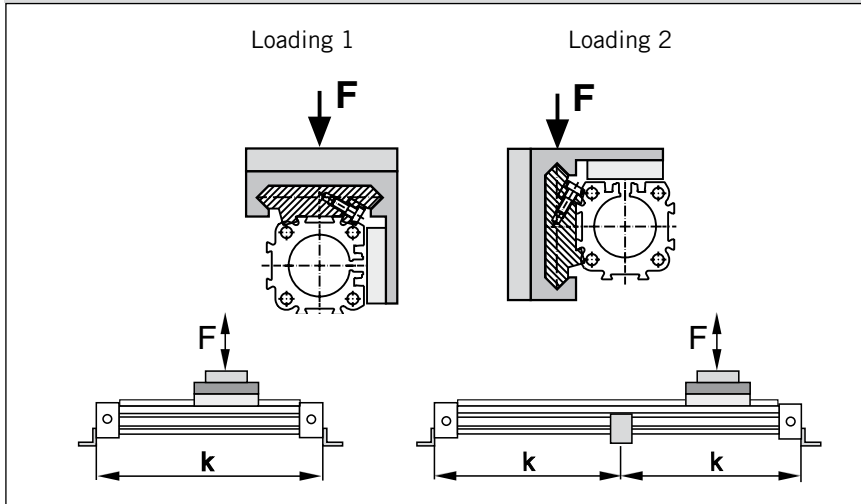

Mid Section Support

(for versions see P-1.45.005E)

Mid section supports are required from a certain stroke length to prevent excessive deflection and vibration of the linear drive.

The diagrams show the maximum permissible unsupported length in relation to loading. A distinction must be drawn between loading 1 and loading 2. Deflection of 0.5 mm max. between supports is permissible.

Note:

For speeds $v > 0.5$ m/s the distance between supports should not exceed 1 m.

Permissible Unsupported Length MB-SL25, MB-SL32

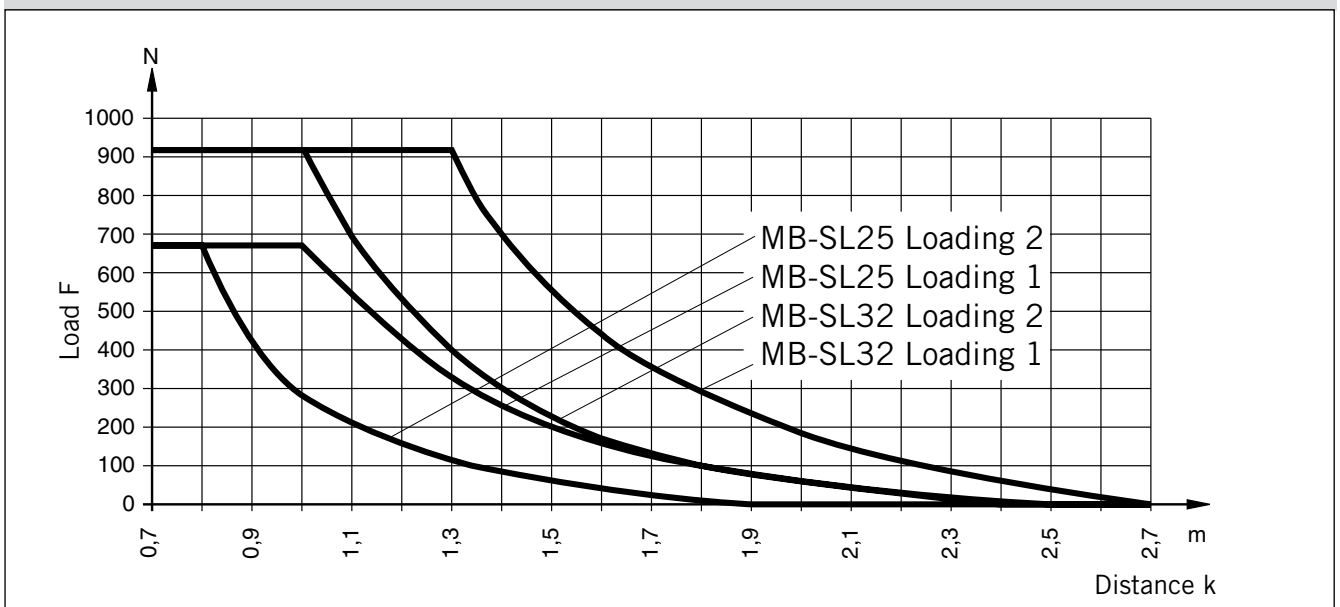

Permissible Unsupported Length MB-SL40, MB-SL50, MB-SL63 and MB-SL80

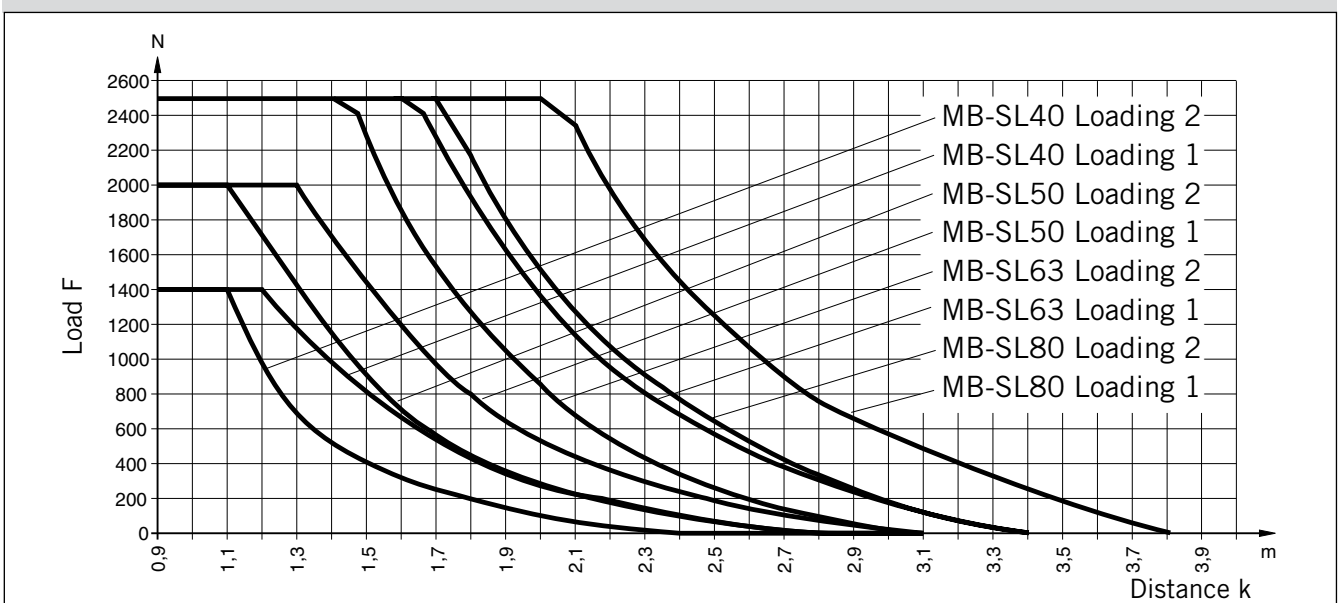

Application Example - Vertical Application

Control of a cylinder with 3/2 way valves. Basic position – **exhausted**

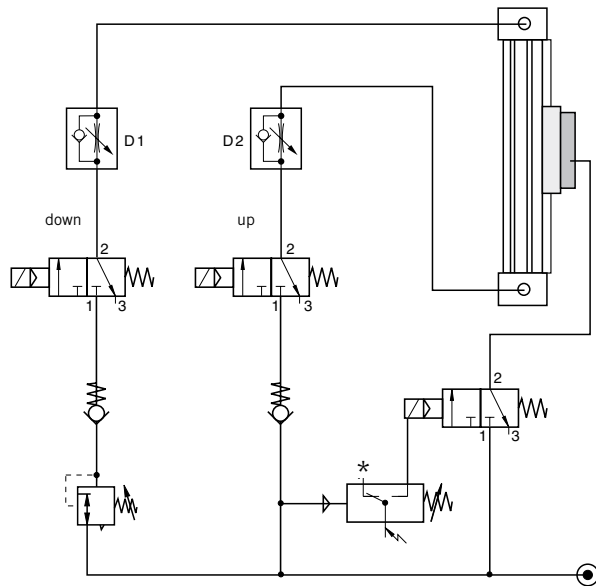

Control of a cylinder with 3/2 way valves. Basic position – **pressurised**

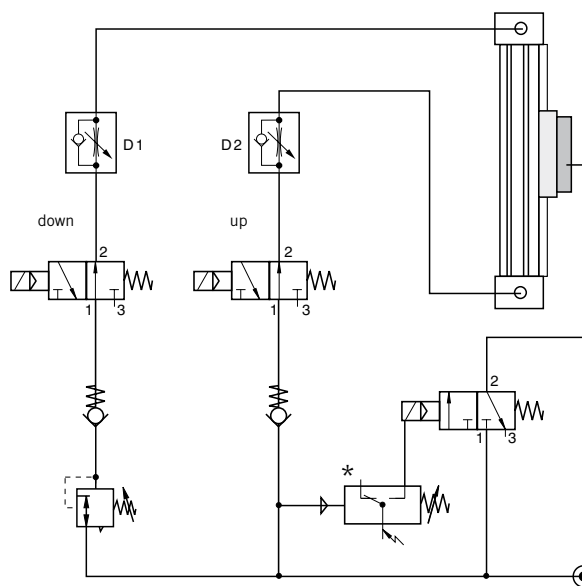

Control Examples

Under normal operating circumstances the pressure switch is closed and the air flows through the 3/2 way solenoid valves from port 1 to 2, thus lifting the brake from the rail (operating condition).

The brake is pressurised by means of a 3/2 way valve in combination with a pressure switch. When there is a pressure loss, the brake is actuated by the pressure switch.

When the air pressure is restored to both cylinder chambers, the brake is lifted and the linear drive can be moved again.

The speed regulating valves D1 and D2 control the speed of the linear drive, and have no influence on the brake. The two non-return valves give the system a higher stability.

The pressure regulating valve is used to compensate for the downward force in this vertical application.

Please note:  **Before the brake is lifted, make sure that both air chambers of the linear drive are pressurised. Small diameter tubing, fittings and valves with a nominal diameter, and tubing that is too long all change the reaction time of the brake!**

*** Tip:** The pressure switch actuates the brake when the pressure drops below the set value.

For accessories, such as tubing and fittings, please refer to our separate catalogue.

Required Components

Way Valves	
Port size	see catalogue
M5, G1/8	Valves
G1/4, G1/2	A4P026E
Pressure Regulating Valves	
G1/8 - G3/8	see catalogue
	Air Preparation
	A4P006E
Pneumatic Accessories	
P/E-Switch	see catalogue
Non-Return Valves	Pneumatic Accessories
G1/8 - G3/8	A4P021E
Screw-in Speed Regulating Valves	
M5 - G1/4	

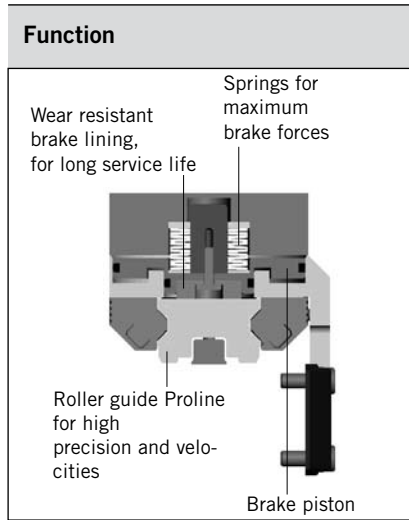
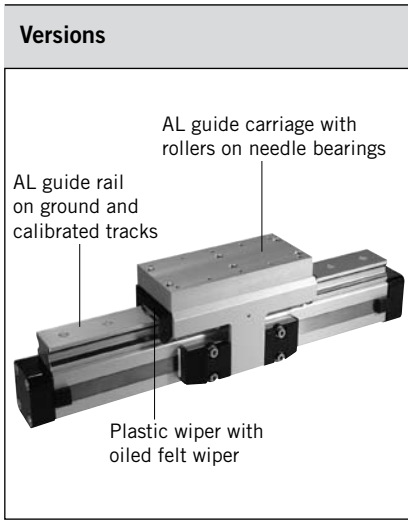

Multi-Brake Passive Brake with Aluminium Roller Guide Proline PL



Series MB-PL 25 to 50
for Linear-drive
• Series OSP-P

Function:

The Multi-Brake is a passive device. When the air pressure is removed the brake is actuated and movement of the cylinder is blocked. The brake is released by pressurisation.

The high friction, wear resistant brake linings allow the Multi-Brake to be used as a dynamic brake to stop cylinder movement in the shortest possible time. The powerful springs also allow the Multi-Brake to be used effectively in positioning applications.

Features:

- Brake operated by spring actuation
- Brake release by pressurisation
- Optional sensor to indicate brake lining wear
- Composite sealing system with plastic and felt wiper elements to remove dirt and lubricate the slideway
- Blocking function in case of pressure loss
- Intermediate stops possible

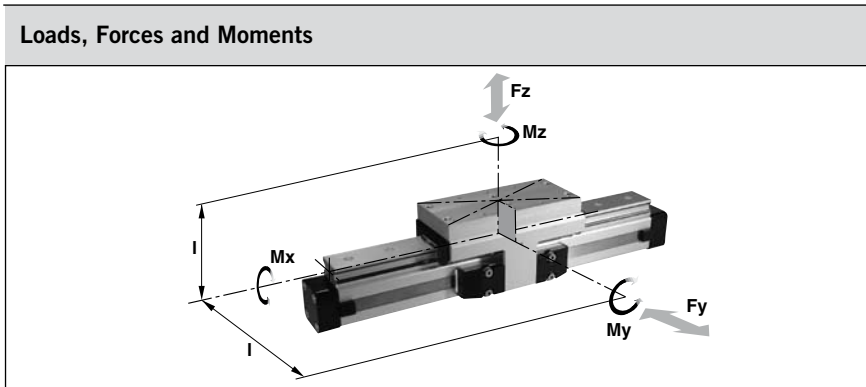

Technical Data

The table shows the maximal permissible loads. If multiple moments and forces act upon the cylinder simultaneously, the following equation applies:

$$\frac{M_x}{M_{x_{max}}} + \frac{M_y}{M_{y_{max}}} + \frac{M_z}{M_{z_{max}}} + \frac{F_y}{F_{y_{max}}} + \frac{F_z}{F_{z_{max}}} \leq 1$$

The sum of the loads should not exceed >1. With a load factor of less than 1, service life is 8000 km

The table shows the maximum permissible values for light, shock-free operation, which must not be exceeded even under dynamic conditions.

Operating Pressure 4.5 - 8 bar. A pressure of min. 4.5 bar release the brake.

¹⁾ Braking surface dry – oil on the braking surface will reduce the braking force

* **Please note:**

In the cushioning diagram, the mass of the guide carriage has to be added to the total moving mass.

Series	For linear drive	Max. moments [Nm]			Max. loads [N] F _y , F _z	Max. brake force [N] ¹⁾	Mass of linear drive with guide [kg]		Mass* guide carriage [kg]	Order No. – MB-PL	
		M _x	M _y	M _z			with 0 mm stroke	increase per 100 mm stroke		without sensor	with sensor for wear indication
MB-PL25	OSP-P25	16	39	39	857	315	2.14	0.40	1.24	20864	on request
MB-PL32	OSP-P32	29	73	73	1171	490	4.08	0.62	2.02	20865	on request
MB-PL40	OSP-P40	57	158	158	2074	715	5.46	0.70	2.82	20866	on request
MB-PL50	OSP-P50	111	249	249	3111	1100	8.60	0.95	4.07	20867	on request

For linear drives see P-1.10.002E
For mountings see P-1.45.005E

Series OSP-P with Passive Brake MB-PL

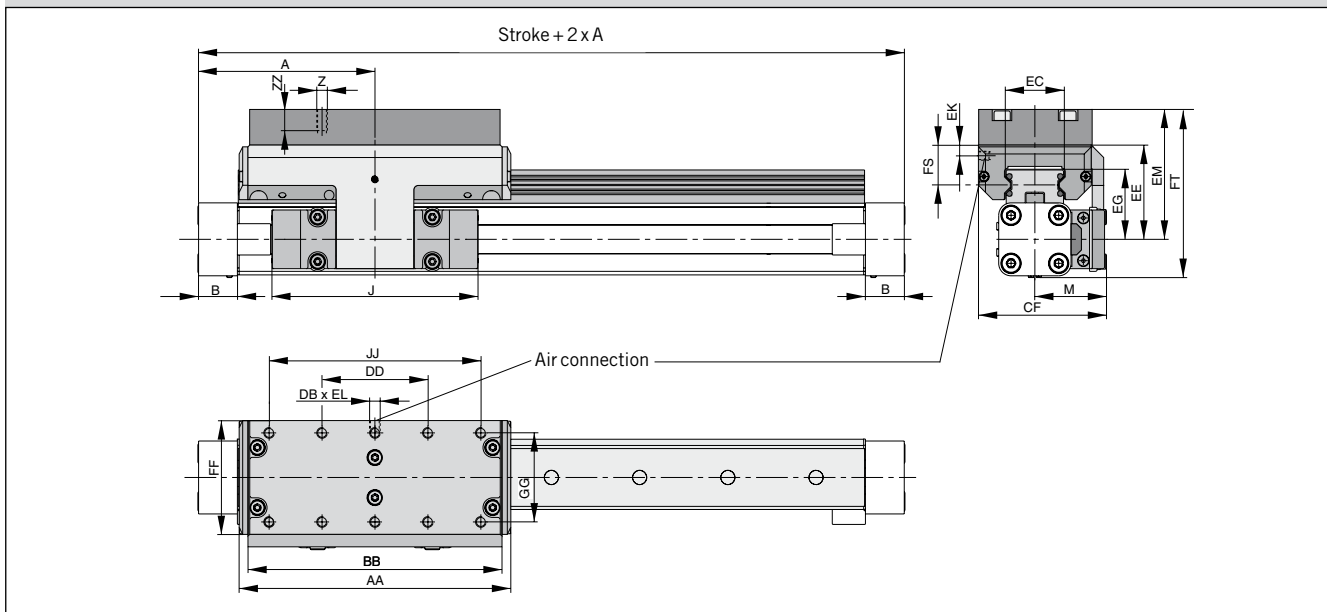

Dimension Table (mm) Series OSP-P MB-PL25, MB-PL32, MB-PL40, MB-PL50

Series	A	B	J	M	Z	AA	BB	DB	DD	CF	EC	EE	EG	EK	EL	EM	FF	FS	FT	GG	JJ	ZZ
MB-PL25	100	22	117	40.5	M6	154	144	M5	60	72.5	32.5	53	39	9	5	73	64	23	93.5	50	120	12
MB-PL32	125	25.5	152	49	M6	197	187	G1/8	80	91	42	62	48	7	10	82	84	25	108	64	160	12
MB-PL40	150	28	152	55	M6	232	222	G1/8	100	102	47	64	50.5	6.5	10	84	94	23.5	118.5	78	200	12
MB-PL50	175	33	200	62	M6	276	266	G1/8	120	117	63	75	57	10	12	95	110	29	138.5	90	240	16

Mid Section Support

(for versions see P-1.45.005E)

Mid section supports are required from a certain stroke length to prevent excessive deflection and vibration of the linear drive. The diagrams show the maximum permissible unsupported length in relation to loading. A distinction must be drawn between loading 1 and loading 2. Deflection of 0.5 mm max. between supports is permissible.

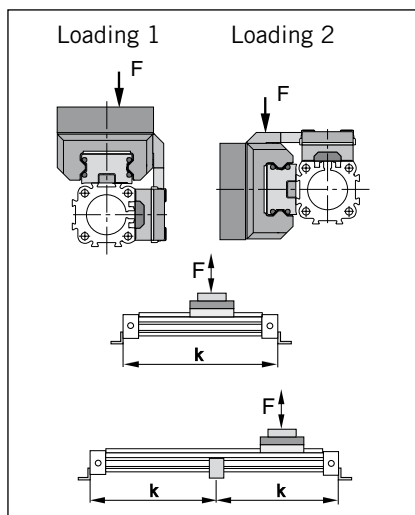

Note:

For speeds $v > 0.5$ m/s the distance between supports should not exceed 1 m.

Permissible Unsupported Length OSP-P MB-PL25, MB-PL32, MB-PL40, MB-PL50

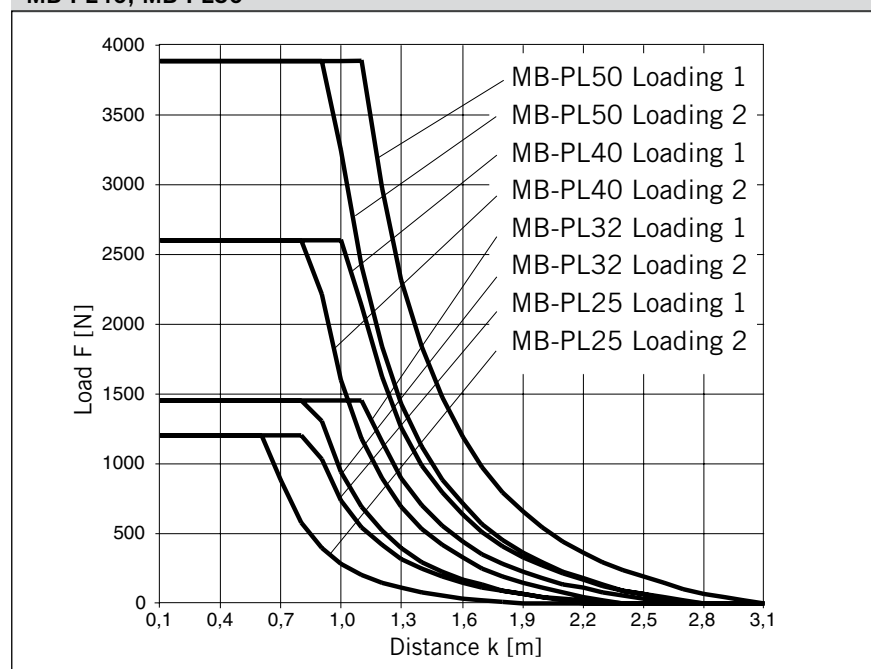

Application Example - Vertical Application

Control of a cylinder with 3/2 way valves. Basic position – **exhausted**

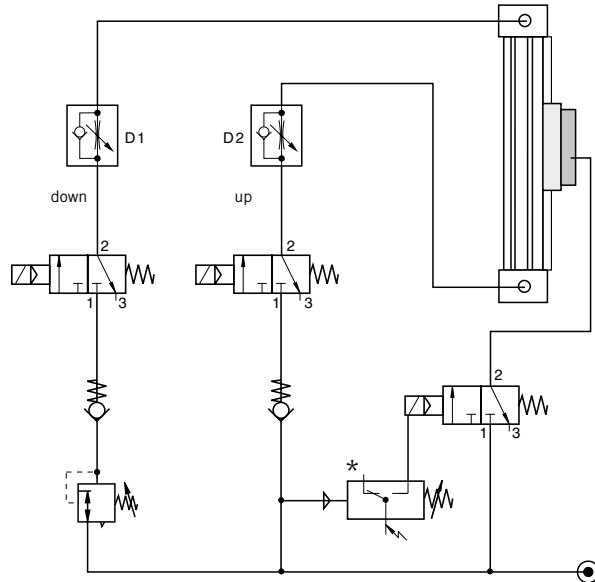

Control of a cylinder with 3/2 way valves. Basic position – **pressurised**

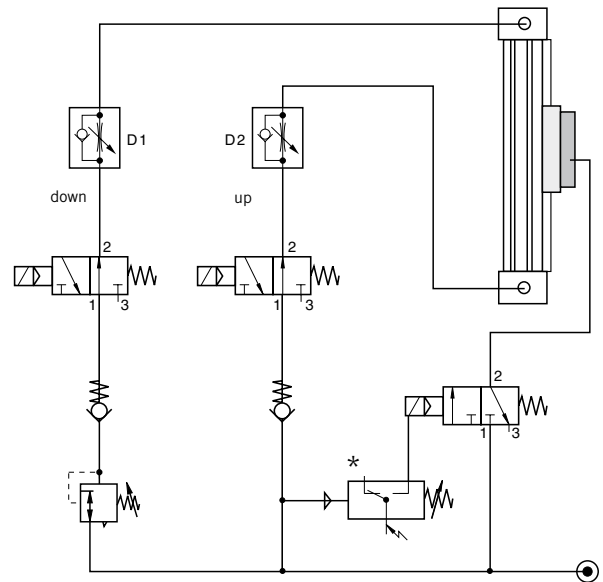

Control Examples

Under normal operating circumstances the pressure switch is closed and the air flows through the 3/2 way solenoid valves from port 1 to 2, thus lifting the brake from the rail (operating condition).

The brake is pressurised by means of a 3/2 way valve in combination with a pressure switch. When there is a pressure loss, the brake is actuated by the pressure switch.

When the air pressure is restored to both cylinder chambers, the brake is lifted and the linear drive can be moved again.

The speed regulating valves D1 and D2 control the speed of the linear drive, and have no influence on the brake. The two non-return valves give the system a higher stability. The pressure regulating valve is used to compensate for the downward force in this vertical application.



Please note:
Before the brake is lifted, make sure that both air chambers of the linear drive are pressurised.
Small diameter tubing, fittings and valves with a nominal diameter, and tubing that is too long all change the reaction time of the brake!

*** Tip:**
 The pressure switch actuates the brake when the pressure drops below the set value.

For accessories, such as tubing and fittings, please refer to our separate catalogue.

Required Components

Way Valves	
Port size	see catalogue
M5, G1/8	Valves
G1/4, G1/2	A4P026E
Pressure Regulating Valves	
G1/8 - G3/8	see catalogue
	Air Preparation
	A4P006E
Pneumatic Accessories	
P/E-Switch	see catalogue
Non-Return Valves	Pneumatic Accessories
G1/8 - G3/8	A4P021E
Screw-in Speed Regulating Valves	
M5 - G1/4	















Linear Drive-Accessories (Mountings and Magnetic Switches) Series OSP-P

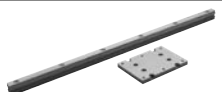

Contents

Description	Data Sheet No.	Page
Overview	P-1.45.001E	83-84
Clevis Mounting	P-1.45.002E	85-86
End Cap Mountings	P-1.45.003E	87
End Cap Mountings (for Linear Drives with guides)	P-1.45.00E-2,-6,-7	89,90,92,94,95
Mid-Section Support	P-1.45.004E	88
Mid-Section Support (for Linear Drives with guides)	P-1.45.005E-3,-5,-8,-9	89,91,93,96,97
Inversion Mounting	P-1.45.006E	99
Adaptor Profile	P-1.45.007E	100
T-Slot Profile	P-1.45.008E	101
Connection Profile	P-1.45.009E	102
Duplex Connection	P-1.45.011E	103
Multiplex Connection	P-1.45.012E	104
Magnetic Switch, standard version	P-1.45.100E	105-107
Magnetic Switch for T-Nut mounting	P-1.45.104E	109-112
Magnetic Switch ATEX-version 	P-1.45.105E	113-115
Cable Cover	P-1.45.102E	108

Linear Drive Accessories for Series OSP-P

Description		Data Sheet No.
Clevis Mounting		P-1.45.002E
End Cap Mountings		P-1.45.003E
End Cap Mountings (for Linear Drives with guides)		P-1.45.005E
Mid-Section Support		P-1.45.004E
Mid-Section Support (for Linear Drives with guides)		P-1.45.005E
Inversion Mounting		P-1.45.006E
Adaptor Profile		P-1.45.007E
T-Slot Profile		P-1.45.008E
Connection Profile		P-1.45.009E
Dulex Connection		P-1.45.011E
Multiplex Connection		P-1.45.012E
Magnetic Switch, standard version		P-1.45.100E
Magnetic Switch, ATEX-version 		P-1.45.105E
Magnetic Switch for T-Nut mounting		P-1.45.104E
Cable cover		P-1.45.102E

A3P111E00HAA00X

The right to introduce technical modifications is reserved

Series OSP-P10

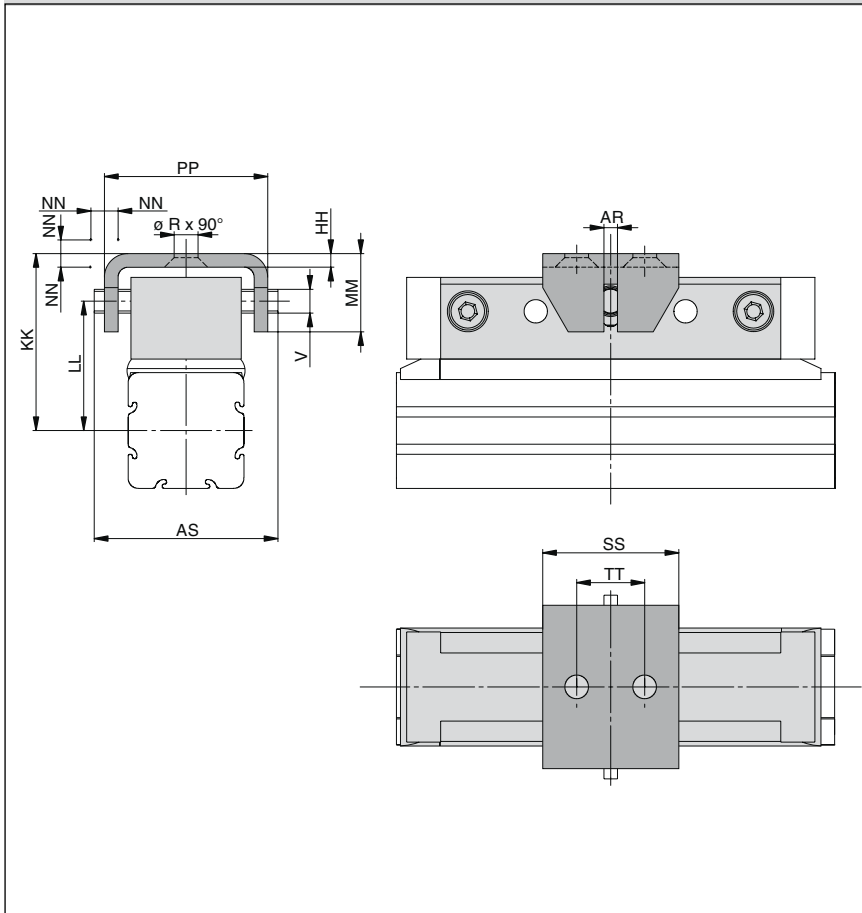

Linear Drive Accessories

ø 10 mm

Clevis Mounting



For Linear-drive
• Series OSP-P

When external guides are used, parallelism deviations can lead to mechanical strain on the piston. This can be avoided by the use of a clevis mounting. In the drive direction, the mounting has very little play. Freedom of movement is provided as follows:

- Tilting in direction of movement
- Vertical compensation
- Tilting sideways
- Horizontal compensation

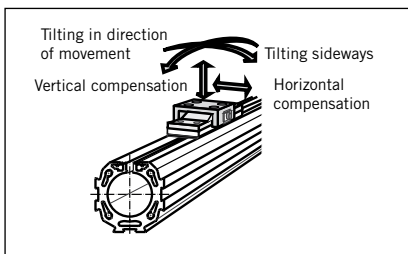

Dimension Table (mm)

Series	øR	V	AR	AS	HH	KK	LL	MM	NN*	PP	SS	TT	Order No.	
													Standard	Stainless
OSP-P10	3.4	3.5	2	27	2	26	19	11.5	1	24	20	10	20971	-

* Dimension NN gives the possible plus and minus play in horizontal and vertical movement, which also makes tilting sideways possible.



For rodless pneumatic cylinder OSP-P see 1.10.002E

P-A1P578D000HAA00X

The right to introduce technical modifications is reserved

Linear Drive Accessories

∅ 16-80 mm Clevis Mounting



For Linear-drive
• Series OSP-P

When external guides are used, parallelism deviations can lead to mechanical strain on the piston. This can be avoided by the use of a clevis mounting. In the drive direction, the mounting has very little play. Freedom of movement is provided as follows:

- Tilting in direction of movement
- Vertical compensation
- Tilting sideways
- Horizontal compensation

A stainless steel version is also available.

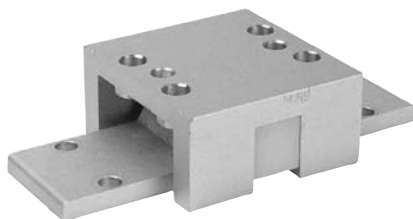

Series OSP-P16 to 32

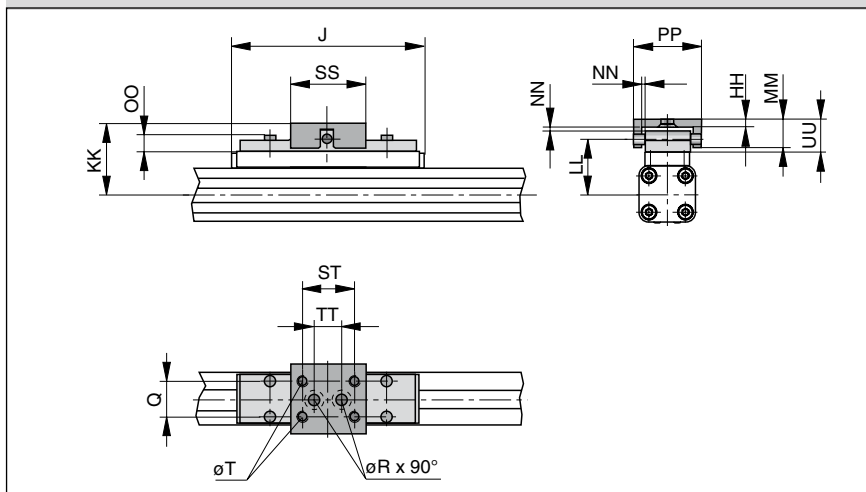

Series OSP-P40 to 80

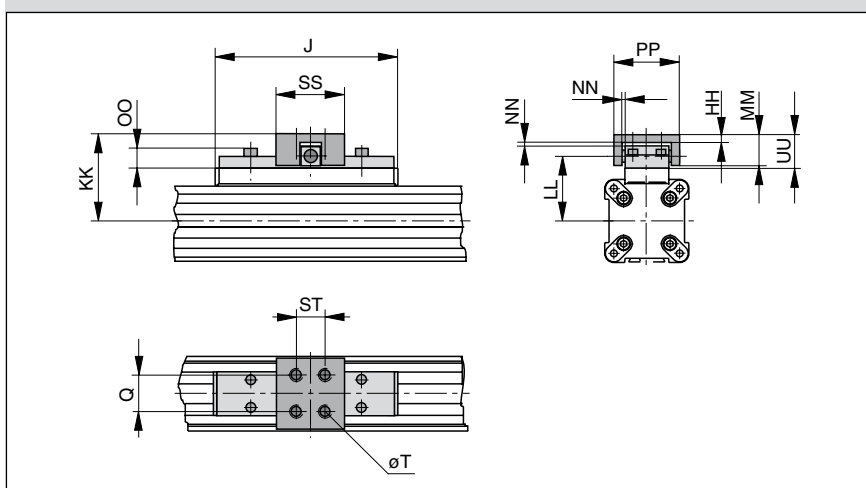

Please note:
When using additional inversion mountings, take into account the dimensions in data sheet P1-.45.006E.

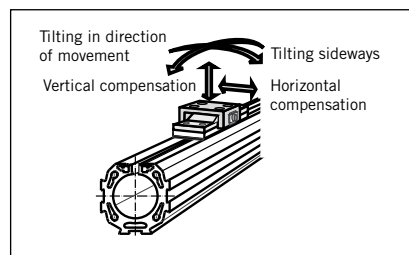

Dimension Table (mm)

Series	J	Q	T	∅R	HH	KK	LL	MM	NN*	OO	PP	SS	ST	TT	UU	Order No.	
																Standard	Stainless
OSP-P16	69	10	M4	4.5	3	34	26.6	10	1	8.5	26	28	20	10	11	20462	20463
OSP-P25	117	16	M5	5.5	3.5	52	39	19	2	9	38	40	30	16	21	20005	20092
OSP-P32	152	25	M6	6.6	6	68	50	28	2	13	62	60	46	40	30	20096	20094
OSP-P40	152	25	M6	-	6	74	56	28	2	13	62	60	46	-	30	20024	20093
OSP-P50	200	25	M6	-	6	79	61	28	2	13	62	60	46	-	30	20097	20095
OSP-P63	256	37	M8	-	8	100	76	34	3	17	80	80	65	-	37	20466	20467
OSP-P80	348	38	M10	-	8	122	96	42	3	16	88	90	70	-	42	20477	20478

* Dimension NN gives the possible plus and minus play in horizontal and vertical movement, which also makes tilting sideways possible.

For rodless pneumatic cylinder OSP-P see 1.10.002E

P-A1P579E00HAA00X

The right to introduce technical modifications is reserved

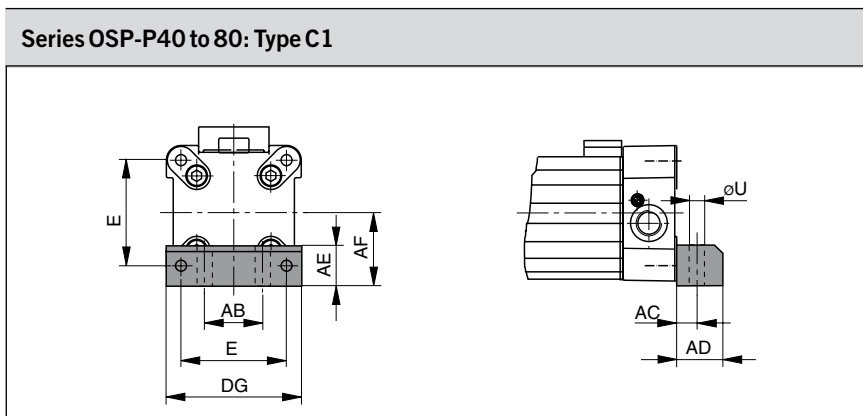
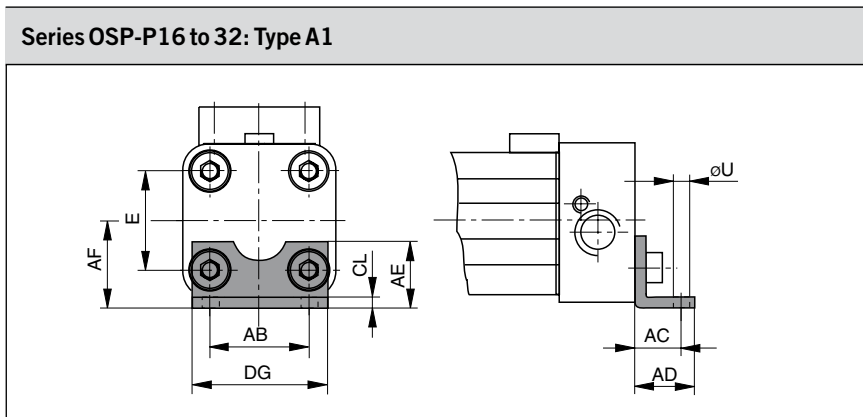
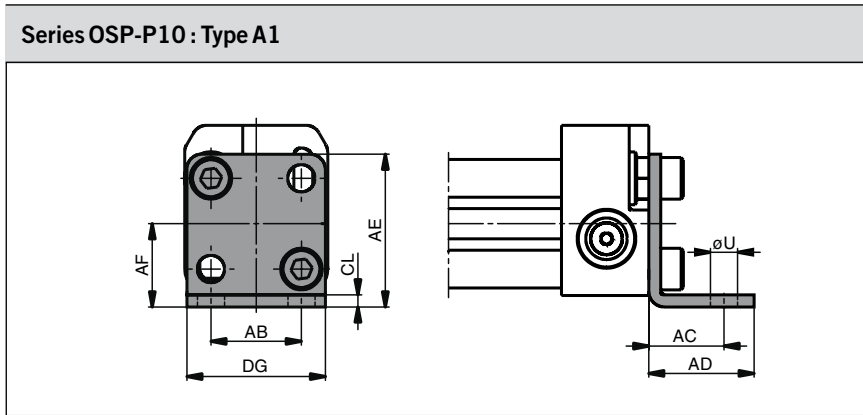

Linear Drive Accessories

ø 10-80 mm

End Cap Mountings



For Linear-drive
• Series OSP-P

On the end-face of each end cap there are four threaded holes for mounting the actuator.

The hole layout is square, so that the mounting can be fitted to the bottom, top or either side, regardless of the position chosen for the air connection.

Material:
Series OSP-P10 – P32:
Galvanised steel.
Series OSP-P40 – P80:
Anodized aluminium.

The mountings are supplied in pairs.

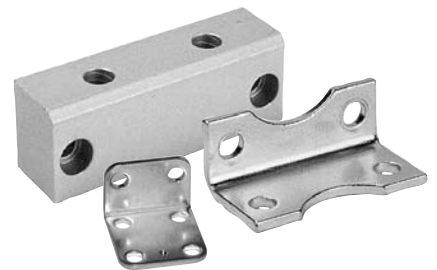

Dimension Table (mm)											
Series	E	ØU	AB	AC	AD	AE	AF	CL	DG	Order No. (* Type A1 Type C1)	
OSP-P10	-	3.6	12	10	14	20.2	11	1.6	18.4	0240	-
OSP-P16	18	3.6	18	10	14	12.5	15	1.6	26	20408	-
OSP-P25	27	5.8	27	16	22	18	22	2.5	39	2010	-
OSP-P32	36	6.6	36	18	26	20	30	3	50	3010	-
OSP-P40	54	9	30	12.5	24	24	38	-	68	-	4010
OSP-P50	70	9	40	12.5	24	30	48	-	86	-	5010
OSP-P63	78	11	48	15	30	40	57	-	104	-	6010
OSP-P80	96	14	60	17.5	35	50	72	-	130	-	8010

(* = Pair)

For rodless pneumatic cylinder OSP-P see 1.10.002E

Linear Drive Accessories

∅ 10-80 mm

Mid-Section Support



For Linear-drive
• Series OSP-P

Note on Types E1 and D1 (P16 – P80):
The mid-section support can also be mounted on the underside of the actuator, in which case its distance from the centre of the actuator is different.

For design notes, see data sheet 1.10.002E-2

Stainless steel version on demand.



Series OSP-10, Type E1
(Mounting from above / below using a cap screw)

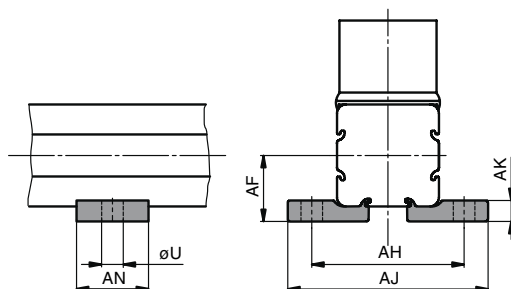

Series OSP-P16 to P80: Type E1
(Mounting from above / below using a cap screw)

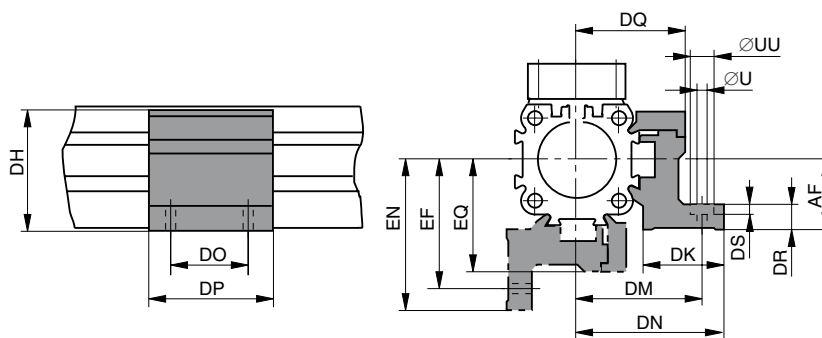

Series OSP-16 to 80, Type D1
(Mountings from below with 2 screws)

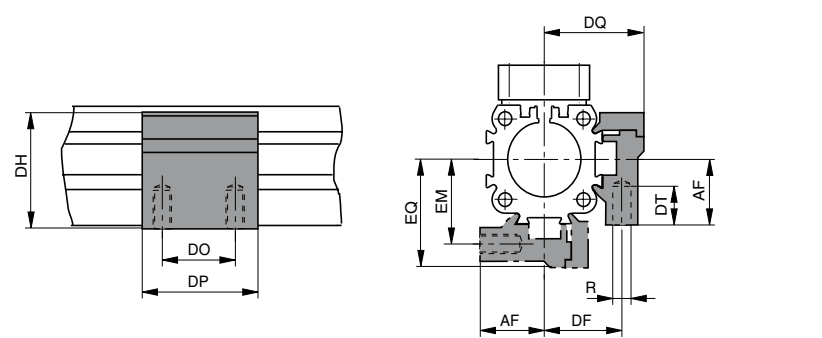

Dimension Table (mm) Series OSP-P10

Series	U	AF	AH	AJ	AK	AN	Order No.	
							Type E1	Type D1
OSP-P10	3.6	11	25.4	33.4	3.5	12	0250	-

Dimension Table (mm) – Series OSP-P16 to P80

Series	R	U	UU	AF	DF	DH	DK	DM	DN	DO	DP	DQ	DR	DS	DT	EF	EM	EN	EQ	Order No.	
																				Type E1	Type D1
OSP-P16	M3	3.4	6	15	20	29.2	24	32	36.4	18	30	27	6	3.4	6.5	32	20	36.4	27	20435	20434
OSP-P25	M5	5.5	10	22	27	38	26	40	47.5	36	50	34.5	8	5.7	10	41.5	28.5	49	36	20009	20008
OSP-P32	M5	5.5	10	30	33	46	27	46	54.5	36	50	40.5	10	5.7	10	48.5	35.5	57	43	20158	20157
OSP-P40	M6	7	-	38	35	61	34	53	60	45	60	45	10	-	11	56	38	63	48	20028	20027
OSP-P50	M6	7	-	48	40	71	34	59	67	45	60	52	10	-	11	64	45	72	57	20163	20162
OSP-P63	M8	9	-	57	47.5	91	44	73	83	45	65	63	12	-	16	79	53.5	89	69	20452	20451
OSP-P80	M10	11	-	72	60	111.5	63	97	112	55	80	81	15	-	25	103	66	118	87	20482	20480





For rodless pneumatic cylinder OSP-P see 1.10.002E

P-A1P580E00HAA00X

The right to introduce technical modifications is reserved

P-A1 P542E00HAA00X

The right to introduce technical modifications is reserved

Overview																		
Mounting Type	Type	Type – OSP Guides																
		SLIDELINE PROLINE MULTIBRAKE						POWERSLIDE										
		16 ¹⁾	25	32	40	50	63 ¹⁾	80 ¹⁾	16/25	25/25	25/35	25/44	32/35	32/44	40/44	40/60	50/60	50/76
End cap mounting 	Type A1	X							X									
	Type A2	O	O	O														
	Type A3									O	O		O					
End cap mounting, reinforced 	Type B1		X	X					X	X	X	X	X					
	Type B3								O									
	Type B4										O		O					
	Type B5																	
End cap mounting 	Type C1			X	X	X	X							X	X	X	X	
	Type C2			O	O													
	Type C3					O	O							O	O			
	Type C4														O	O		
Mid section support, small	Type D1	X	X	X	X	X	X	X	X	X	X	X	X	X	X	X	X	
Mid section support, wide	Type E1	X	X	X	X	X	X	X	X	X	X	X	X	X	X	X	X	
	Type E2	O	O	O	O	O												
	Type E3					O	O	O	O	O		O	O	O	O			
	Type E4										O	O	O	O				
	Type E5																	

- X = carriage mounted in top (12 o'clock position)
- O = carriage mounted in lateral (3 or 9 o'clock position)
- = available components
- 1) = not available for all sizes

Linear Drive Accessories

Mountings for Linear Drives fitted with OSP-Guides



For Linear-drives
• Series OSP-P

Note:
For mountings and mid-section supports for linear drives with recirculating ball bearing guide STARLINE see data sheet P-1.45.005E-6 to P-1.45.005E-9, for recirculating ball bearing guide KF see data sheet P-1.45.005E-4 to P-1.45.005E-9.



For rodless pneumatic cylinder OSP-P see 1.10.002E

End cap mountings*

Four internal screw threads are located in the end faces of all OSP actuators for mounting the drive unit. End cap mountings may be secured across any two adjacent screws.

Material:

Series OSP-16, 25, 32:
Galvanised steel

Series OSP-40,50, 63, 80:
Anodized aluminium

The mountings are supplied in pairs.

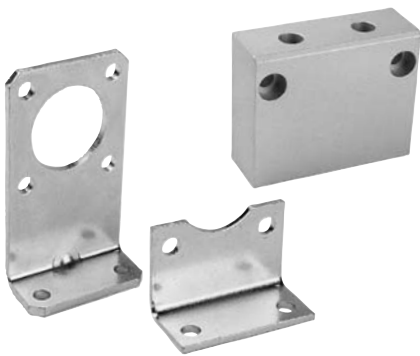

Series OSP-P16, 25, 32: Type A

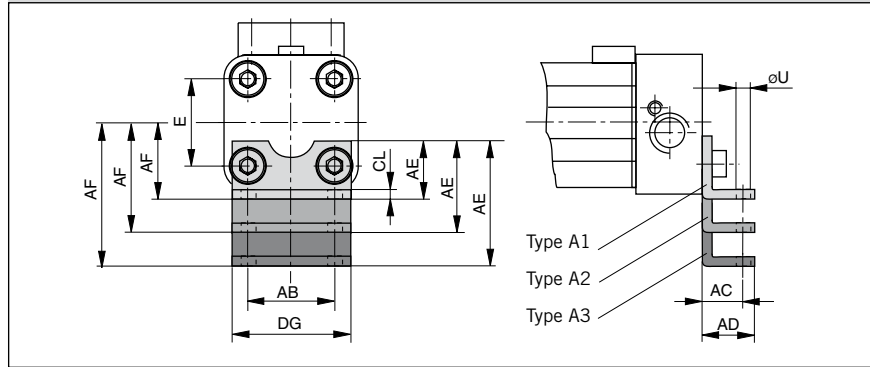

Series OSP-P16, 25, 32: Type B

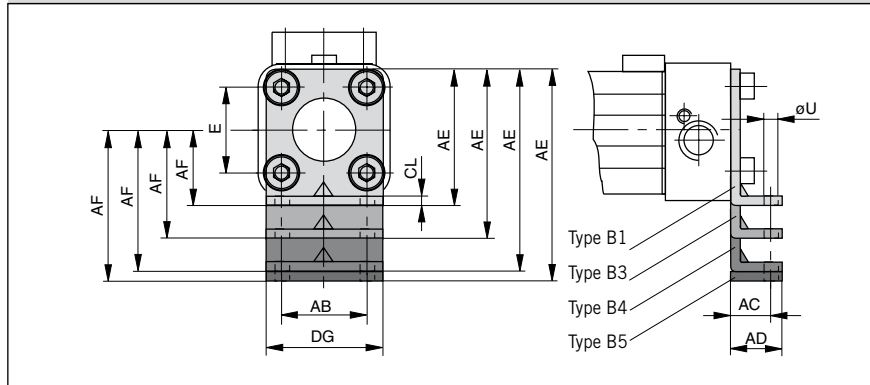

Dimension Table (mm)														
– Dimensions AE and AF (Dependant on the mounting type)														
Mount. type	Dimensions AE for size								AF for size					
	16	25	32	40	50	63	80	16	25	32	40	50	63	80
A1	12.5	18	20	-	-	-	-	15	22	30	-	-	-	-
A2	27.5	33	34	-	-	-	-	30	37	44	-	-	-	-
A3	-	45	42	-	-	-	-	49	52	-	-	-	-	-
B1	-	42	55	-	-	-	-	22	30	-	-	-	-	-
B3	55	-	-	-	-	-	-	42	-	-	-	-	-	-
B4	-	80	85	-	-	-	-	60	60	-	-	-	-	-
B5	-	-	90	-	-	-	-	-	65	-	-	-	-	-
C1	-	-	-	24	30	40	50	-	-	-	38	48	57	72
C2	-	-	-	37	39	-	-	-	-	-	51	57	-	-
C3	-	-	-	46	54	76	88	-	-	-	60	72	93	110
C4	-	-	-	56	77	-	-	-	-	-	70	95	-	-

Series OSP-P40, 50, 63, 80: Type C

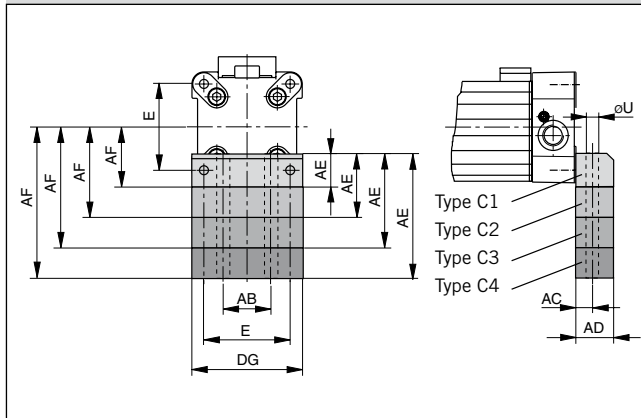

Dimension Table (mm)							
Series	E	øU	AB	AC	AD	CL	DG
OSP-P16	18	3.6	18	10	14	1.6	26
OSP-P25	27	5.8	27	16	22	2.5	39
OSP-P32	36	6.6	36	18	26	3	50
OSP-P40	54	9	30	12.5	24	-	68
OSP-P50	70	9	40	12.5	24	-	86
OSP-P63	78	11	48	15	30	-	104
OSP-P80	96	14	60	17.5	35	-	130

* see mounting instructions on page P-1.45.005E-1

Linear Drive Accessories

Ø 25-50 mm

End Cap Mounting correspond to FESTO dimensions HP25 – 50

for Linear Drives with Recirculating Ball Bearing Guide

- Series OSP-P KF

On the end-face of each end cap there are four threaded holes for mounting the actuator.

Material:

Series OSP-P KF25 – 50:
Anodized aluminium.

The mountings are supplied in pairs.

Series OSP-P KF25 to KF50: Type HP (Correspond to FESTO dimensions)

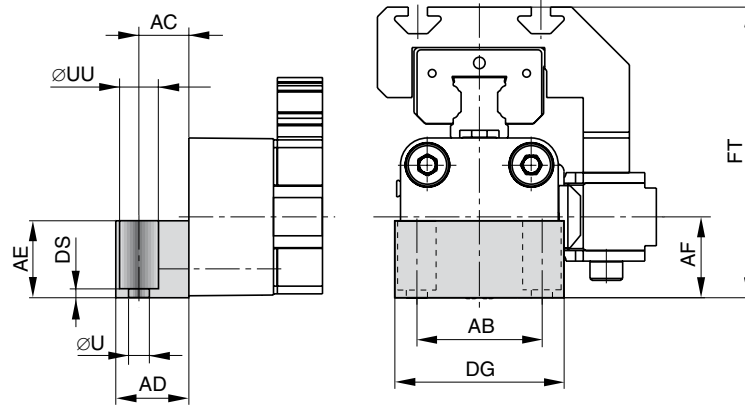

Note:
Correspond to FESTO DGPL-KF, when the End Cap Mountings HP are mounted on the opposite side to the carriage (see drawing)

Dimension Table (mm)

Series	ØU	AB	AC	AD	AE	AF	DG	DS	FT	ØUU	Order No.
HP25	5.5	32.5	13	19	20	21	44	2	75.5	10	21107
HP32	6.6	38	17	24	24	27	52	3	87.5	11	21108
HP40	6.6	45	17.5	24	24	35	68	2	104.5	11	21109
HP50	9	65	25	35	35	48	86	6	138.5	15	21110

Series OSP-P KF25: Type MUP
(Mounting over through holes)

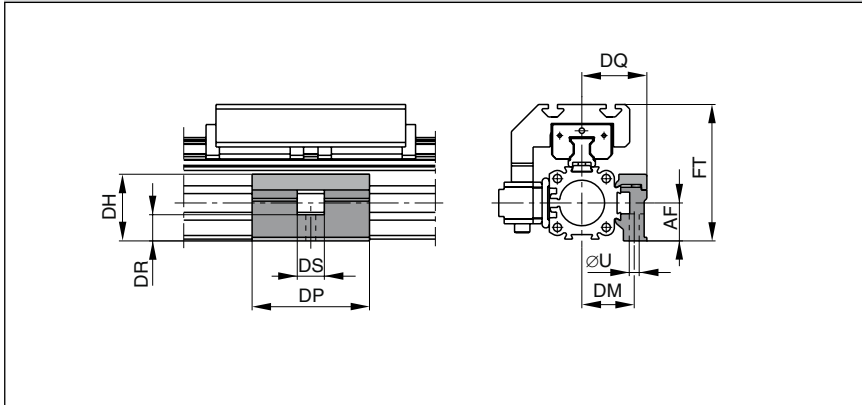

Linear Drive Accessories

Ø 25-50 mm

Mid-Section Support correspond to FESTO dimensions MUP25 – 50

for Linear Drives with Recirculating Ball Bearing Guide

Series OSP-P KF32 to KF40: Type MUP
(Mounting over through holes)

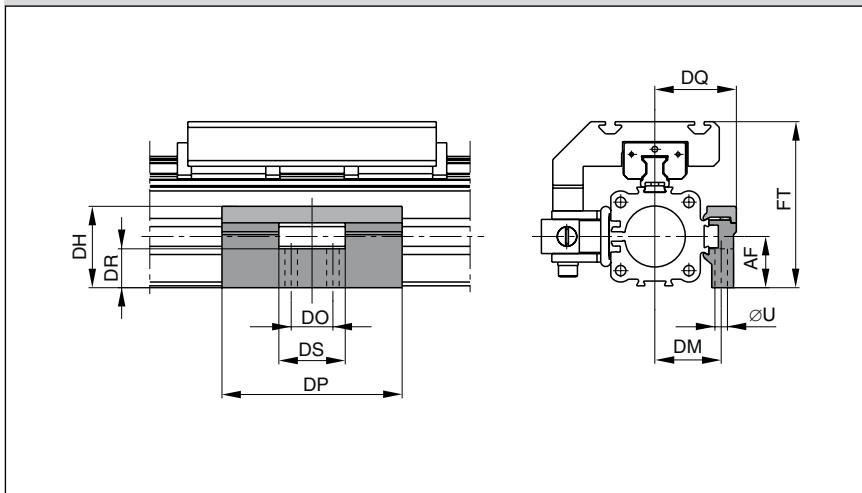

• Series OSP-P KF

For design notes, see data sheet P-1.40.007E-3

Series OSP-P KF50: Type MUP
(Mounting over through holes)

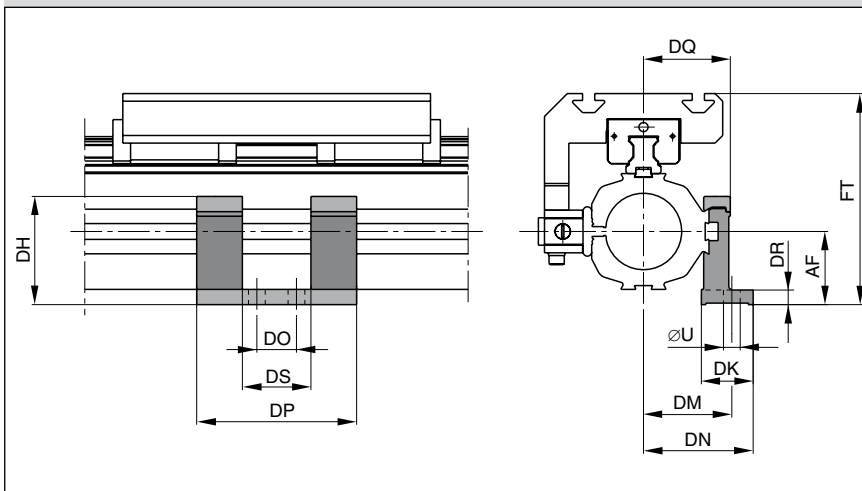

Note:
Correspond to FESTO DGPL-KF, when the Mid-Section Support MUP are mounted on the 90° side to the carriage (see drawings).

Dimension Table (mm)

Series	øU	AF	DH	DK	DM	DN	DO	DP	DQ	DR	DS	FT	Order No.
MUP25	5.5	21	36.9	–	29	–	–	65	36	14.5	15	75.5	21119
MUP32	6.6	27	42.9	–	35	–	22	95	43	20.5	35	87.5	21120
MUP40	6.6	35	58	–	40	–	22	95	48	28.5	35	104.5	21121
MUP50	11	48	71	34	58	72	26	105	57	10	45	138.5	21122

Linear Drive Accessories

Ø 16 to 32 mm

End Cap Mounting

Type: B

for Linear Drives with Recirculating Ball Bearing Guide

- Series OSP-P STL
- Series OSP-P KF

Material:

Galvanised steel
Anodized aluminium

The mountings are supplied in pairs.

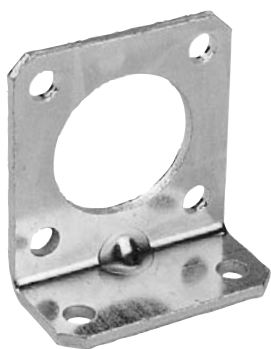

Series OSP-P STL16, STL25, STL32 : Type B1
Series OSP-P KF16, KF25, KF32 : Type B1

Installation:

Top carrier
Side piston

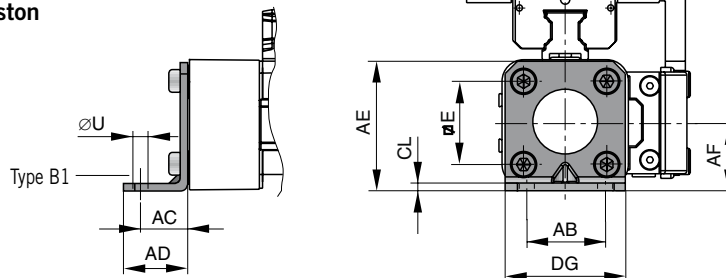

Drawing shows: Mounting with Guide Type STL

Series OSP-P STL16, STL25, STL32: Type B3 (Ø 32:B5)
Series OSP-P KF16, KF25, KF32: Type B3 (Ø 32:B5)

Installation:

Side carrier
Piston below

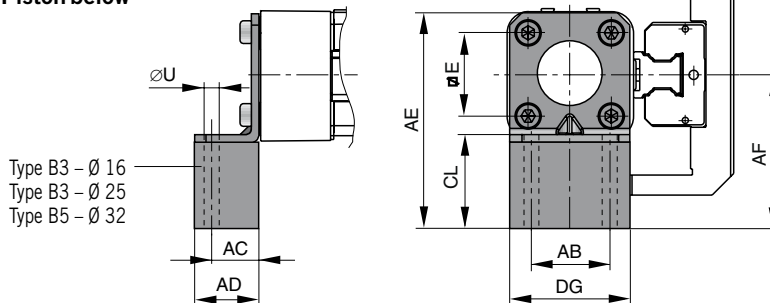

Drawing shows: Mounting with Guide Type STL

Series OSP-P STL16, STL25, STL32: Type B2
Series OSP-P KF16, KF25, KF32: Type B2

Installation:

Side carrier
Top piston

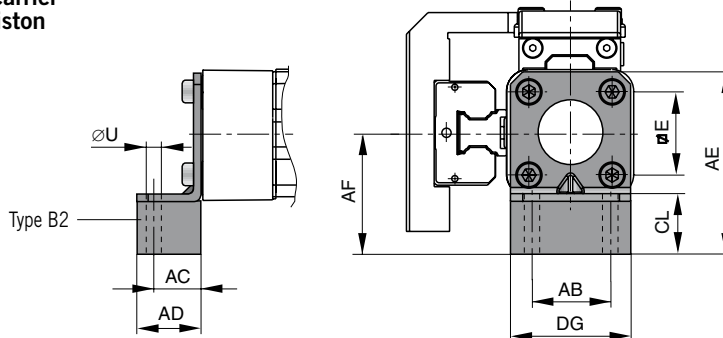

Drawing shows: Mounting with Guide Type STL

Dimension Table (mm) for End Cap Mounting Type: B1 to B5

Series Type	Mounting	E	ØU	AB	AC	AD	AE	AF	CL	DG	Order No. (pair)
OSP-PSTL16 OSP-PKF16	B1	18	3.6	18	10	14	28	15	2	26	21135
	B2	18	3.6	18	10	14	43	30	17	26	21136
	B3	18	3.6	18	10	14	55	42	29	26	21137
OSP-PSTL25 OSP-PKF25	B1	27	5.8	27	16	22	42	22	2.5	39	20311
	B2	27	5.8	27	16	22	57	37	17.5	39	21138
	B3	27	5.8	27	16	22	69	49	29.5	39	21139
OSP-PSTL32 OSP-PKF32	B1	36	6.6	36	18	26	55	30	3	50	20313
	B2	36	6.6	36	18	26	69	44	17	50	21140
	B5	36	6.6	36	18	26	90	65	9	50	21141

Series OSP-P STL40, STL50: Type C1
 Series OSP-P KF40, KF50: Type C1

Installation:

Top carrier
 Side piston

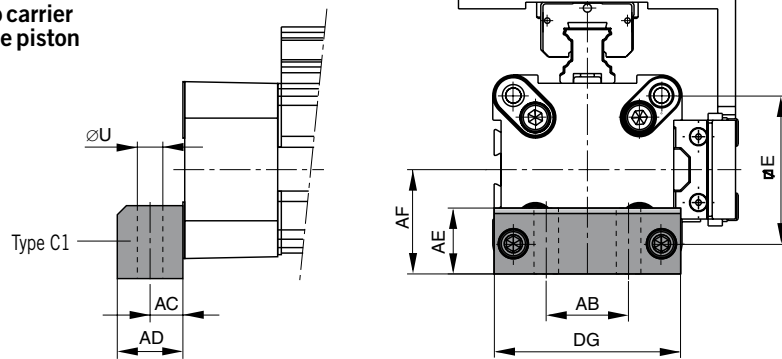

Drawing shows: Mounting with Guide Type STL

Ø 40 to 50 mm End Cap Mounting Type: C

for Linear Drives with Recirculating
 Ball Bearing Guide

- Series OSP-P STL
- Series OSP-P KF

Material:

Anodized aluminium

The mountings are supplied in pairs.

Series OSP-P STL40, STL50: Type C4 (Ø 50: C3)
 Series OSP-P KF40, KF50: Type C4 (Ø 50: C3)

Installation:

Side carrier
 Piston below

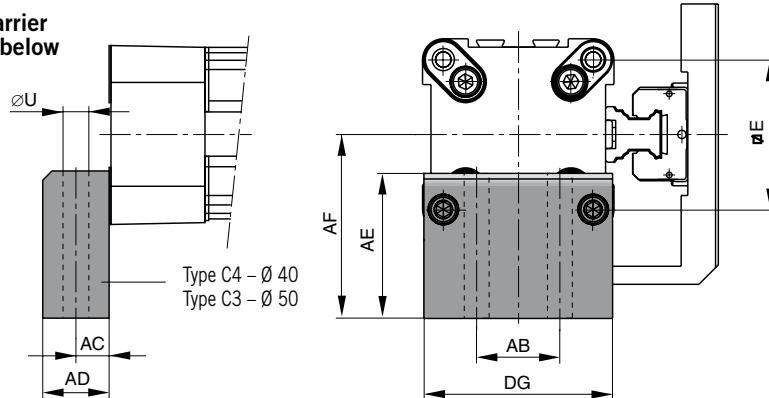

Drawing shows: Mounting with Guide Type STL

Series OSP-P STL40, STL50: Type C2
 Series OSP-P KF40, KF50: Type C2

Installation:

Side carrier
 Top piston

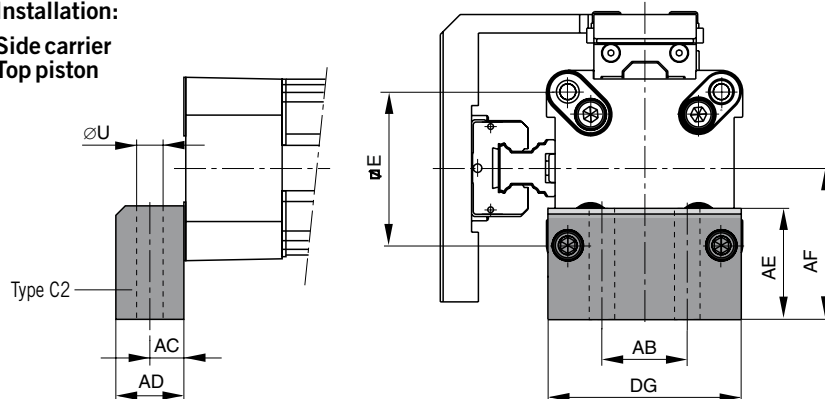

Drawing shows: Mounting with Guide Type STL

Dimension Table (mm) for End Cap Mounting Type: C1 to C4

Series Type	Mounting	E	ØU	AB	AC	AD	AE	AF	DG	Order No. (pair)
OSP-PSTL40	C1	54	9	30	12.5	24	24	38	68	4010
OSP-PKF40	C2	54	9	30	12.5	24	37	51	68	20338
	C4	54	9	30	12.5	24	56	70	68	20340
OSP-PSTL50	C1	70	9	40	12.5	24	30	48	86	5010
OSP-PKF50	C2	70	9	40	12.5	24	39	57	86	20349
	C3	70	9	40	12.5	24	54	72	86	20350



Linear Drive Accessories

Ø 16 to 50

Mid-Section Support

Type: D1ST

for Linear Drives with Recirculating Ball Bearing Guide

- Series OSP-P STL
- Series OSP-P KF

Note on Types D1ST

The mid-section support can also be mounted on the underside of the actuator, in which case its distance from the centre of the actuator is different.

For design notes, see page
P-1.40.006E-3 (Serie OSP-P STL)
P-1.40.007E-3 (Serie OSP-P KF)



Series OSP-P STL16 to STL50: Type D1ST
Series OSP-P KF16 to KF50: Type D1ST

Mountings from below with 2 screws

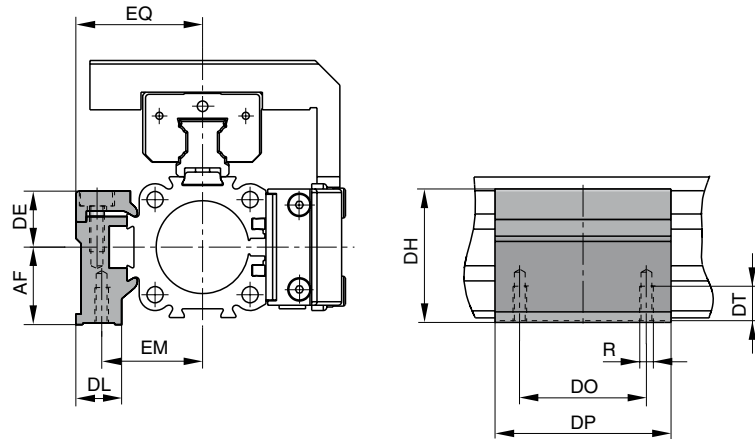

Drawing shows: Mounting with Guide Type STL

Dimension Table (mm) Mid-Section Support D1ST

Series OSP-P	Mounting Type	R	AF	DE	DH	DL	DO	DP	DT	EM	EQ	Order No.
STL/KF16	D1ST	M3	15	14.2	29.2	14.6	18	30	6.5	20	27	21125
STL/KF25	D1ST	M5	22	16	38	13	36	50	10	28.5	36	21126
STL/KF32	D1ST	M5	30	16	46	13	36	60	10	35.5	43	21127
STL/KF40	D1ST	M6	38	23	61	19	45	60	11	38	48	21128
STL/KF50	D1ST	M6	48	23	71	19	45	60	11	45	57	21129

Order example: Type D1ST16 Order No. 21125

Mid-Section Support

Type: E1ST bis E5ST

for Linear Drives with Recirculating Ball Bearing Guide

- Series OSP-P STL
- Series OSP-P KF



Series OSP-P STL16 to STL50: Type E1ST
Series OSP-P KF16 to KF50: Type E1ST

Installation:

Top carrier
Side position

Mounting from above / below
using a cap screw

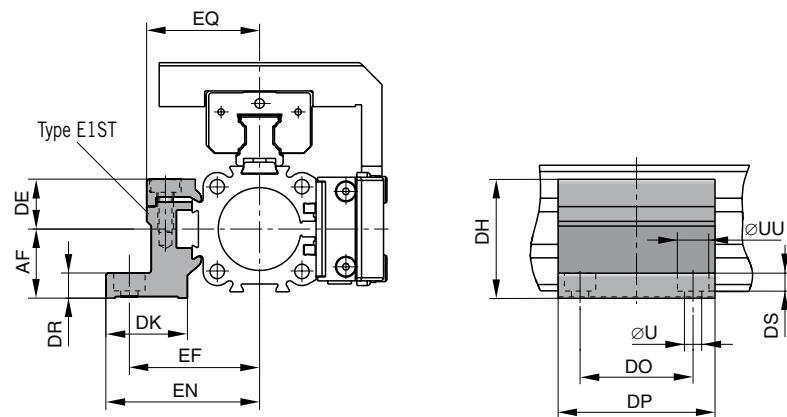

Drawing shows: Mounting with Guide Type STL

Series OSP-P STL25 to STL50: Type E3ST, E4ST, E5ST
 Series OSP-P STL25 to STL50: Type E3ST, E4ST, E5ST

Installation:

Side carrier
 Piston below

Mounting from above / below
 using a cap screw

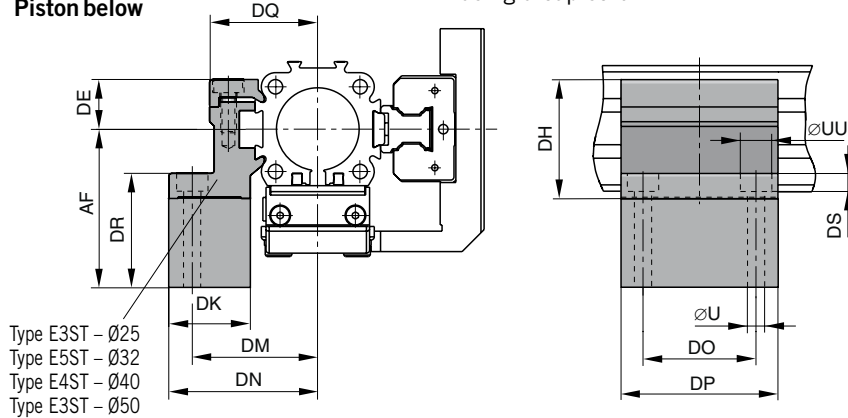

Drawing shows: Mounting with Guide Type STL

Mid-Section Support Type: E1ST to E5ST

for Linear Drives with
 Recirculating Ball Bearing Guide

- Series OSP-P STL
- Series OSP-P KF

Series OSP-P STL16 to STL50: Type E2ST
 Series OSP-P KF16 to KFL50: Type E2ST

Installation:

Side carrier
 Top piston

Mounting from above / below
 using a cap screw

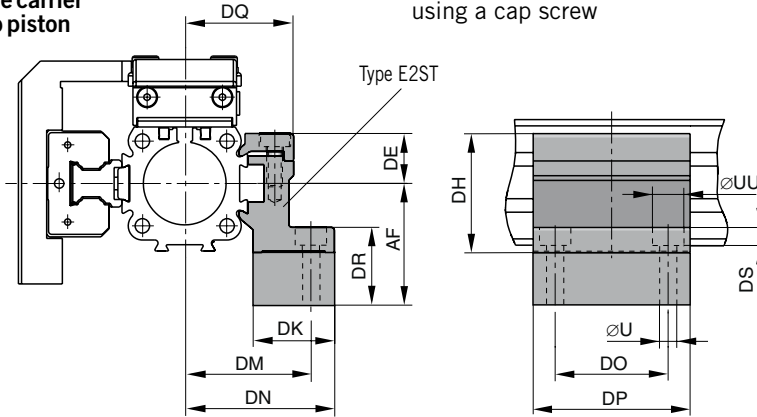

Drawing shows: Mounting with Guide Type STL



Dimension Table (mm) for Mid-Section Support E1ST to E5ST

Series OSP-P	Mounting Type	ØU	ØUU	AF	DE	DH	DK	DM	DN	DO	DP	DR	DQ	DS	EF	EN	EQ	Order No.
STL/KF16	E1ST	3.4	6	15	14.2	29.2	24	32	36.4	18	30	6	27	3.4	32	36.4	27	21130
STL/KF16	E2ST	3.4	6	30	14.2	29.2	24	32	36.4	18	30	21	27	3.4	32	36.4	27	21142
STL/KF25	E1ST	5.5	10	22	16	38	26	40	47.5	36	50	8	34.5	5.7	41.5	49	36	21131
STL/KF25	E2ST	5.5	10	37	16	38	26	40	47.5	36	50	23	34.5	5.7	41.5	49	36	21143
STL/KF25	E3ST	5.5	10	49	16	38	26	40	47.5	36	50	35	34.5	5.7	41.5	49	36	21148
STL/KF32	E1ST	5.5	10	30	16	46	27	46	54.5	36	60	10	40.5	5.7	48.5	57	43	21132
STL/KF32	E2ST	5.5	10	44	16	46	27	46	54.5	36	60	24	40.5	5.7	48.5	57	43	21144
STL/KF32	E5ST	5.5	10	65	16	46	27	46	54.5	36	60	45	40.5	5.7	48.5	57	43	21151
STL/KF40	E1ST	7	-	38	23	61	34	53	60	45	60	10	45	-	56	63	48	21133
STL/KF40	E2ST	7	-	51	23	61	34	53	60	45	60	23	45	-	56	63	48	21145
STL/KF40	E4ST	7	-	70	23	61	34	53	60	45	60	42	45	-	56	63	48	21150
STL/KF50	E1ST	7	-	48	23	71	34	59	67	45	60	10	52	-	64	72	57	21134
STL/KF50	E2ST	7	-	57	23	71	34	59	67	45	60	19	52	-	64	72	57	21146
STL/KF50	E3ST	7	-	72	23	71	34	59	67	45	60	34	52	-	64	72	57	21149

Order example: Type E1ST16

Order No. 21130

P-AIP581E00HAA00X

The right to introduce technical modifications is reserved

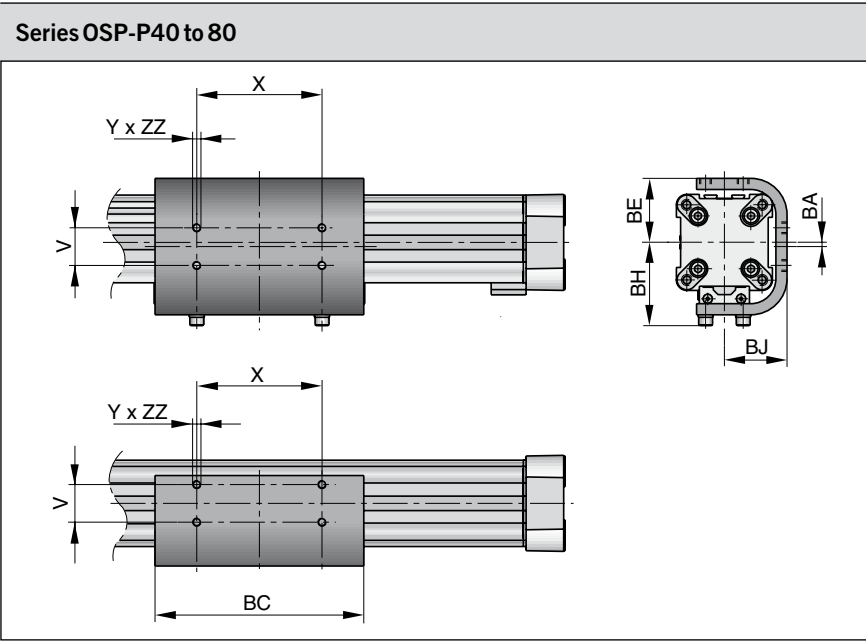
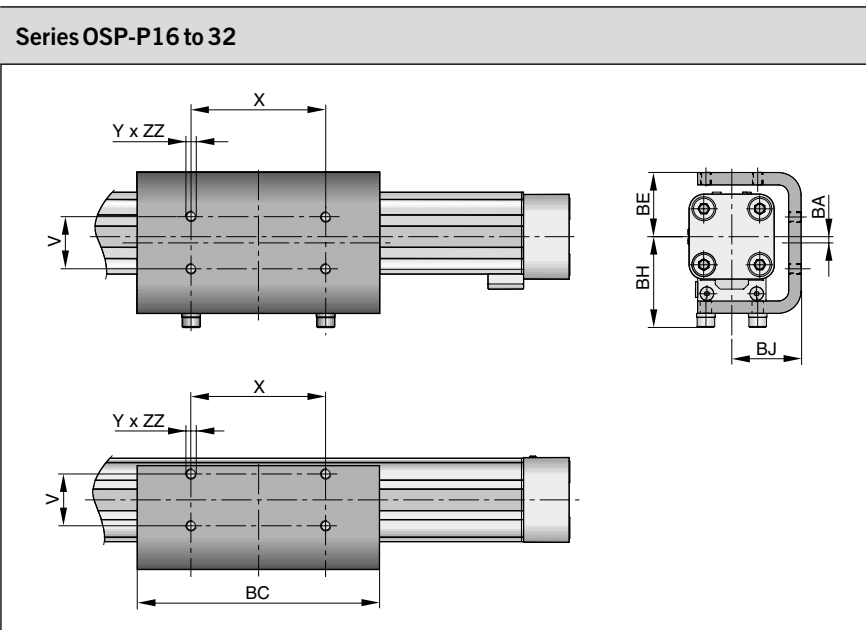

Dimension Table (mm)										
Series	V	X	Y	BA	BC	BE	BH	BJ	ZZ	Order No.
OSP-P16	16,5	36	M4	2	69	23	33	25	4	20446
OSP-P25	25	65	M5	3	117	31	44	33,5	6	20037
OSP-P32	27	90	M6	3	150	38	52	39,5	6	20161
OSP-P40	27	90	M6	3	150	46	60	45	8	20039
OSP-P50	27	110	M6	1	200	55	65	52	8	20166
OSP-P63	34	140	M8	2,5	255	68	83,5	64	10	20459
OSP-P80	36	190	M10	3,5	347	88	107,5	82	15	20490

For rodless pneumatic cylinder OSP-P see 1.10.002E

Linear Drive Accessories

∅ 16-80 mm

Inversion Mounting



For Linear-drive
• Series OSP-P

In dirty environments, or where there are special space problems, inversion of the cylinder is recommended. The inversion bracket transfers the driving force to the opposite side of the cylinder. The size and position of the mounting holes are the same as on the standard cylinder.

Stainless steel version on demand.

Please note:
Other components of the OSP system such as **mid-section supports, magnetic switches and the external air passage for the P16**, can still be mounted on the free side of the cylinder.

When combining single end porting with inversion mountings, RS magnetic switches can only be mounted directly opposite to the external air-supply profile.

Important Note:
May be used in combination with Clevis Mounting, ref. dimensions in data sheet P-1.45.002E



Linear Drive Accessories

∅ 16-50 mm Adaptor Profile



For Linear-drive
• Series OSP-P

Adaptor Profile OSP

- A universal attachment for mounting of valves etc.
- Solid material



Series OSP-P16 to 50

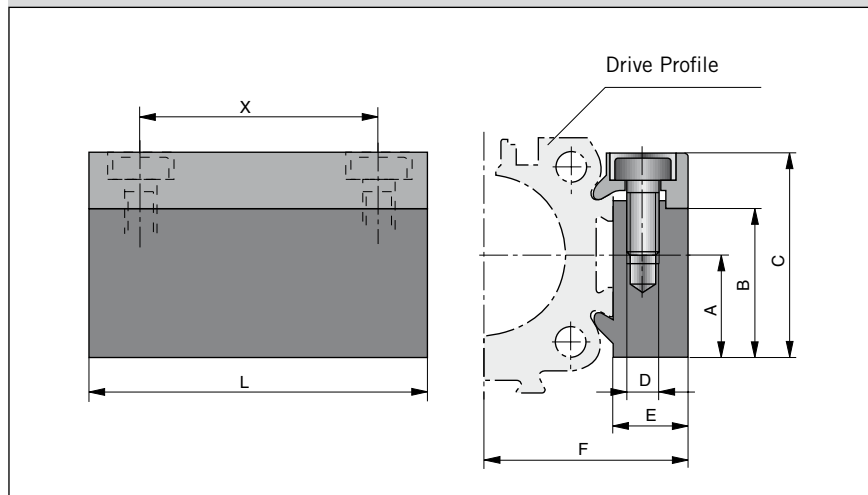

Dimension Table (mm)

Series	A	B	C	D	E	F	L	X	Order No.	
									Standard	Stainless
OSP-P16	14	20.5	28	M3	12	27	50	38	20432	20438
OSP-P25	16	23	32	M5	10.5	30.5	50	36	20006	20186
OSP-P32	16	23	32	M5	10.5	36.5	50	36	20006	20186
OSP-P40	20	33	43	M6	14	45	80	65	20025	20267
OSP-P50	20	33	43	M6	14	52	80	65	20025	20267

Series OSP-P63 to 80

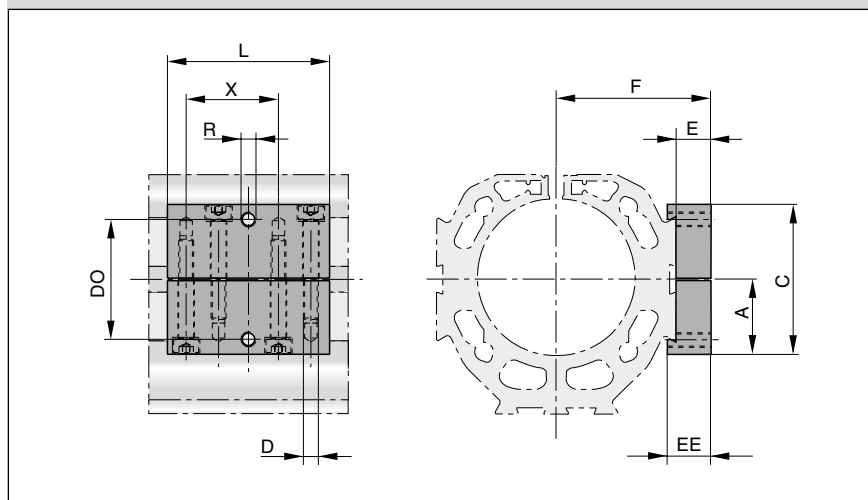

Dimension Table (mm)

Series	A	C	D	E	F	L	R	X	EE	DO	Order No. *
OSP-P63	30	60	M6	14	62	65	M6	37	17,5	48	20792Z
OSP-P80	30	60	M6	14	75	65	M6	37	17,5	48	20792Z

* Stainless version

For rodless pneumatic cylinder OSP-P see 1.10.002E

P-A1P582E00AH00X

The right to introduce technical modifications is reserved

P-A1P583E00AHH00X

The right to introduce technical modifications is reserved

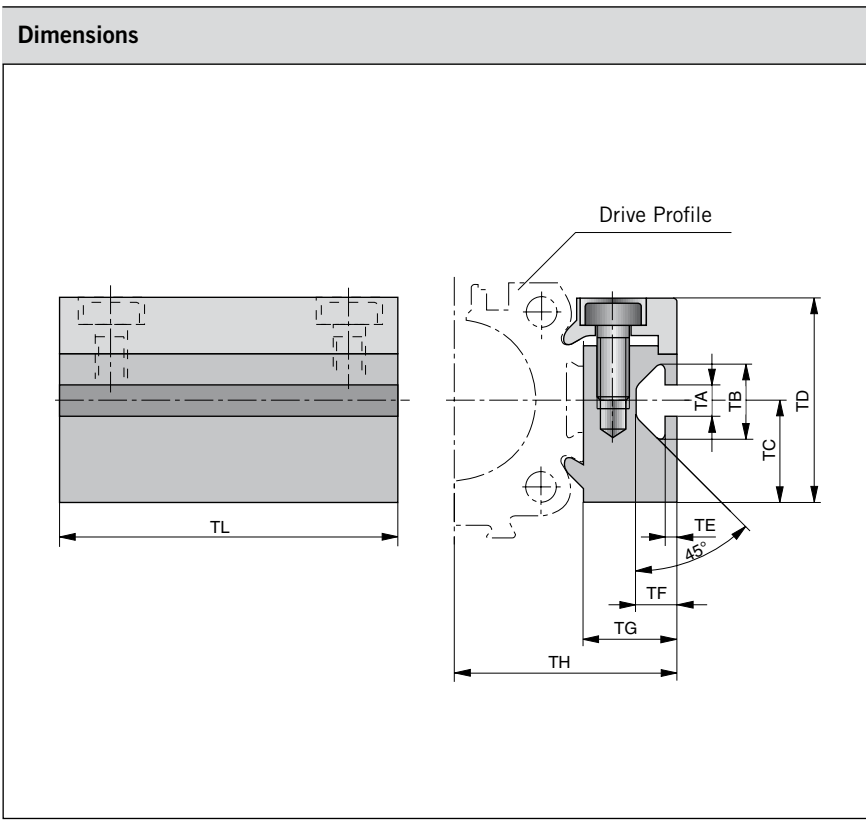

Linear Drive Accessories

∅ 16-50 mm

T-Slot Profile



For Linear-drive
• Series OSP-P

T-Slot Profile OSP
• A universal attachment for mounting with standard T-Nuts

Dimension Table (mm)											
Series	TA	TB	TC	TD	TE	TF	TG	TH	TL	Order No.	
										Standard	Stainless
OSP-P16	5	11.5	14	28	1.8	6.4	12	27	50	20433	20439
OSP-P25	5	11.5	16	32	1.8	6.4	14.5	34.5	50	20007	20187
OSP-P32	5	11.5	16	32	1.8	6.4	14.5	40.5	50	20007	20187
OSP-P40	8.2	20	20	43	4.5	12.3	20	51	80	20026	20268
OSP-P50	8.2	20	20	43	4.5	12.3	20	58	80	20026	20268

Following T-nuts from the company ITEM could be used:

Cyl.-Series	T-nut St 5	T-nut St 8
OSP-P16-32	●	
OSP-P40-50		●

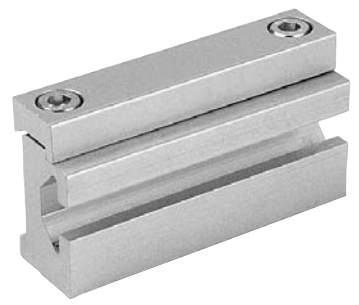

For rodless pneumatic cylinder OSP-P see 1.10.002E

Linear Drive Accessories

∅ 16-50 mm Connection Profile



- For combining
- Series OSP-P with system profiles
 - Series OSP-P with Series OSP-P

Dimensions

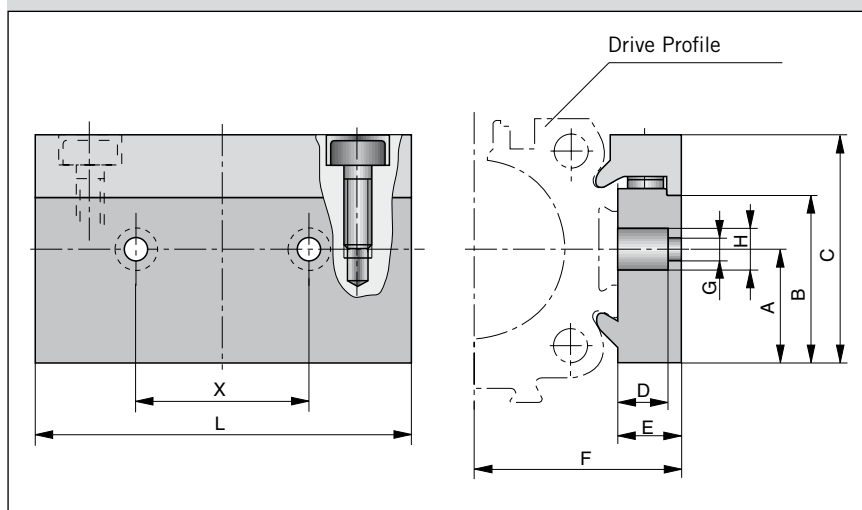

Dimension Table (mm)

Cylinder Series	for mounting on the carrier of	A	B	C	D	E	F	G	H	L	X	Order No.
OSP-P16	OSP25	14	20.5	28	8.5	12	27	5.5	10	50	25	20849
OSP-P25	OSP32-50	16	23	32	8.5	10.5	30.5	6.6	11	60	27	20850
OSP-P32	OSP32-50	16	23	32	8.5	10.5	36.5	6.6	11	60	27	20850
OSP-P40	OSP32-50	20	33	43	8	14	45	6.6	11	60	27	20851
OSP-P50	OSP32-50	20	33	43	8	14	52	6.6	11	60	27	20851

Possible Combinations

Combination of Series OSP-P with system profiles

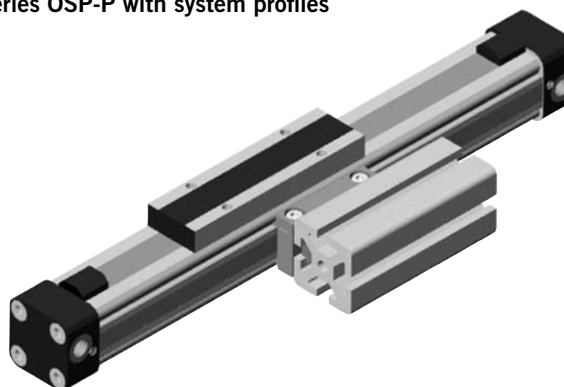

Combination of Series OSP-P with Series OSP-P

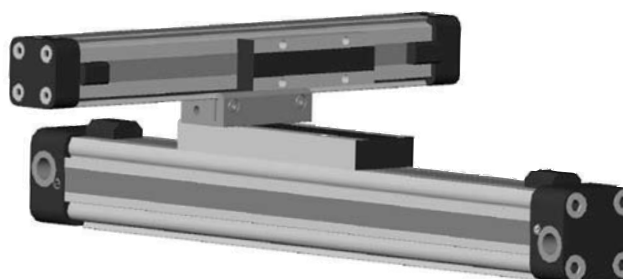

For rodless pneumatic cylinder OSP-P see 1.10.002E

P-A1P681E00AH00X

The right to introduce technical modifications is reserved

P-A1P705E00HAD00X

The right to introduce technical modifications is reserved

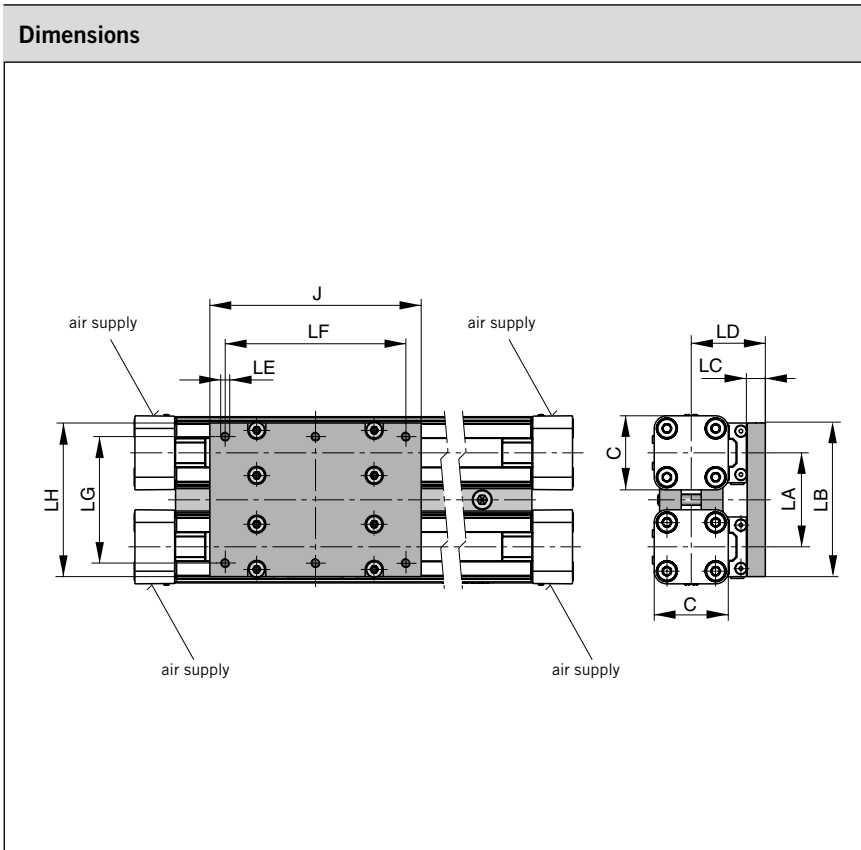

Dimension Table (mm)

Cylinder Series	C	J	LA	LB	LC	LD	LE	LF	LG	LH	Order No.	
											Standard	Stainless
OSP-P25	41	117	52	86	10	41	M5	100	70	85	20153	20194
OSP-P32	52	152	64	101	12	50	M6	130	80	100	20290	20291
OSP-P40	69	152	74	111	12	56	M6	130	90	110	20156	20276
OSP-P50	87	200	88	125	12	61	M6	180	100	124	20292	20293

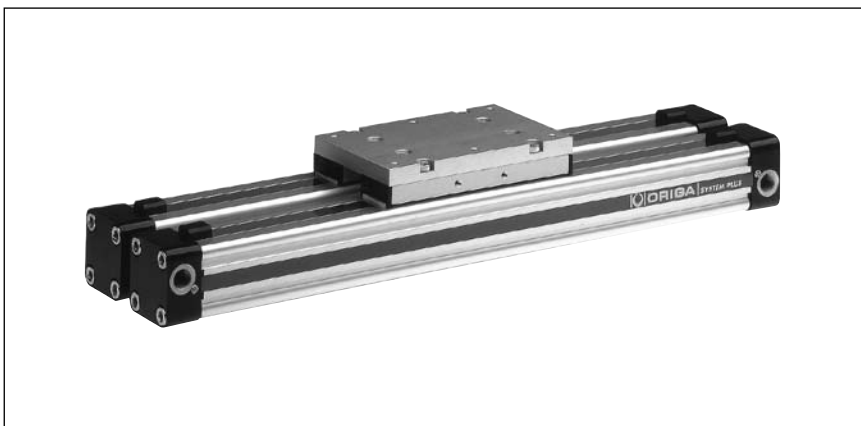

Linear Drive Accessories

∅ 25-50 mm Duplex Connection



For connection of cylinders of the Series OSP-P

The duplex connection combines two OSP-P cylinders of the same size into a compact unit with high performance.

Features

- increased load and torque capacity
- higher driving forces

Included in delivery:

- 2 clamping profiles with screws
- 1 mounting plate with fixings

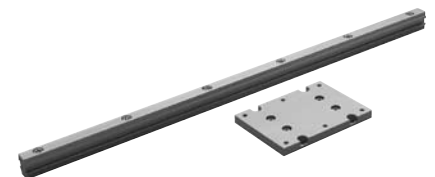

For rodless cylinders OSP-P see 1.10.002E

Linear Drive Accessories

∅ 25-50 mm

Multiplex Connection



For connection of cylinders of the Series OSP-P

The multiplex connection combines two or more OSP-P cylinders of the same size into one unit.

Features

- The orientation of the carriers can be freely selected

Included in delivery:

2 clamping profiles with clamping screws

Dimensions

Installation:
Top carrier/Top carrier

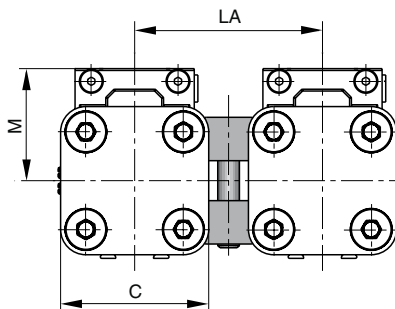

Installation:
Top carrier/Side carrier

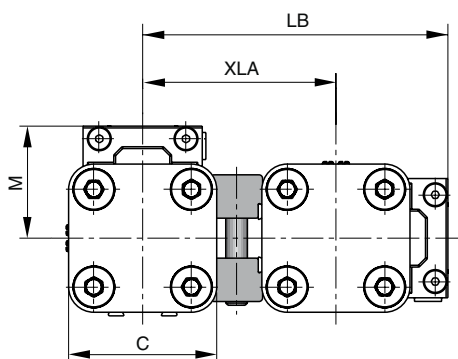

Dimension Table (mm)

Cylinder Series	C	M	LA	LB	XLA	Order No.	
						Standard	Stainless
OSP-P25	41	31	52	84.5	53.5	20035	20193
OSP-P32	52	38	64	104.5	66.5	20167	20265
OSP-P40	69	44	74	121.5	77.5	20036	20275
OSP-P50	87	49	88	142.5	93.5	20168	20283



For rodless cylinders OSP-P see 1.10.002E

P-A1P706E00HAD00X

The right to introduce technical modifications is reserved

Characteristics			
Characteristics	Unit	Description	
Electrical Characteristics		Type RS	Type ES
Switching output		Reed	PNP, NPN
Operating voltage	V	10-240 AC/DC (NO) 10-150 AC/DC (NC)	10-30 DC
Residual voltage	V	< 3	< 3
Connection		Two wire	Three wire
Output function		normally open normally closed	normally open
Permanent current	mA	200	200
Max. switching capacity	VA (W)	10 VA	—
Power consumption without load	mA	—	< 20
Function indicator		LED, yellow	
Typical switching time	ms	On: < 2	On: < 2
Switch-off delay	ms	—	ca. 25
Pole reversal does not work		LED	—
Pole reversal protection		—	Built in
Short-circuit protection		—	Built in
Switchable capacity load	µF	0.1 at 100 Ω, 24 VDC	
Switching point accuracy	mm	± 0,2	
Switching distance	mm	ca. 15	ca. 15
Hysteresis for OSP	mm	ca. 8	ca. 3
Lifetime		3 x 10 ⁶ , up to 6 x 10 ⁶ cycles	Theoretically unlimited
Mechanical Characteristics			
Housing		Makrolon, smoke color	
Cable cross section	mm ²	2 x 0.14	3 x 0.14
Cable type *)		PVC	PUR, black
Bending radius fixed	mm	≥ 20	
moving	mm	≥ 70	
Weight (Mass)	kg	0.012	
Degree of protection	IP	67 to DIN EN 60529	
Ambient temperature range *) ¹⁾	°C °C	-25 other temperature ranges +80 on request	
Shock resistance	m/s ²	100 (contact switches)	500

*) other versions on request

¹⁾ for the magnetic switch temperature range, please take into account the surface temperature and the self-heating properties of the linear drive.

Linear Drive Accessories

∅ 10-80 mm Magnetic Switches

OSP
— ORIGA
— SYSTEM
— PLUS

For electrical sensing of the carrier position, e.g. at the end positions, magnetic switches may be fitted. Position sensing is contactless and is based on magnets fitted as standard to the carrier. A yellow LED indicates operating status.

The universal magnetic switches are suitable for all Parker Origa OSP-Actuators and aluminum profile rod type cylinders.

Piston, speed and switching distance affect signal duration and should be considered in conjunction with the minimum reaction time of ancillary control equipment.

$$\text{Min. reaction time} = \frac{\text{Switching distance}}{\text{Piston speed}}$$



For linear drives see 1.10.002E

ORIGA

Type RS

In the type RS contact is made by a mechanical **reed switch** encapsulated in glass.
Direct connection with 2-pole cable, 5 m long, open ended (**Type RS-K**).

Type ES

In the type ES contact is made by an **electronic switch** – without bounce or wear and protected from pole reversal. The output is short circuit proof and insensitive to shocks and vibrations. Connection is by 3-pole connector for easy disconnection. Fitted with connection cable 100 mm long with connector.
A 5 m cable with connector and open end can be ordered separately, or use the Order No. for the complete Type ES with 5 m cable.

Magnetic Switches RS and ES

Electrical Service Life Protective Measures

Magnetic switches are sensitive to excessive currents and inductions. With high switching frequencies and inductive loads such as relays, solenoid valves or lifting magnets, service life will be greatly reduced.

With **resistive and capacitive loads** with high switch-on current, such as light bulbs, a protective resistor should be fitted. This also applies to long cable lengths and voltages over 100 V.

In the switching of inductive loads such as relays, solenoid valves and

lifting magnets, voltage peaks (transients) are generated which must be suppressed by protective diodes, RC loops or varistors.

Connection Examples

Load with protective circuits
(a) Protective resistor for light bulb
(b) Freewheel diode on inductivity
(c) Varistor on inductivity
(d) RC element on inductivity

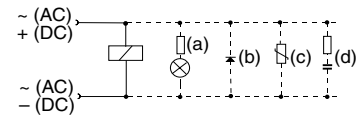

For the type ES, external protective circuits are not normally needed.

Electrical Connection, Type RS

Normally closed (NC)

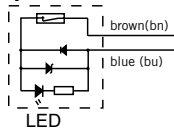

Normally open (NO)

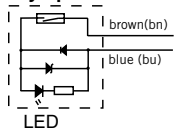

Dimensions (mm) – Type RS-K

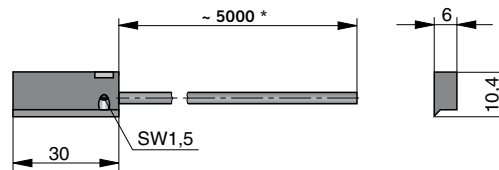

* Length with possible minus tolerance, see chart below

Electrical Connection, Type ES

Standard Version: Type PNP

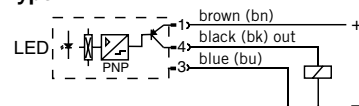

Optional Version Type NPN

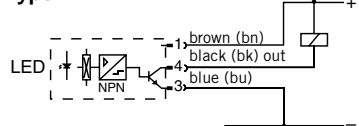

Dimensions (mm) – Type ES-S

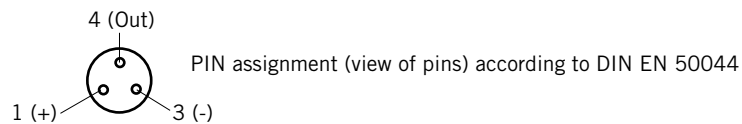
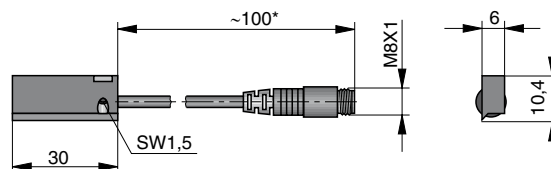

* Length with possible minus tolerance, see chart below

Length of connection cable with length tolerance

Magnetic Switch Order No.	Nominal cable length	Length tolerance
KL3045	5000 mm	-50 mm
KL3048	5000 mm	-50 mm
KL3054	100 mm	-20 mm
KL3060	145 mm	±5 mm

Dimensions Series OSP-P10

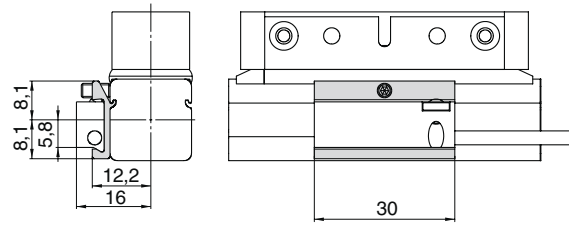

Note:
Sensors can not be mounted directly opposite of the carrier

Dimensions Series OSP-P16 to 80

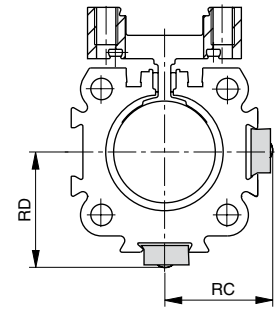

Dimension Table (mm) and Order Instructions

Series	Dimensions		Order No.						
	RC	RD	RS closer Normally open	RS opener Normally closed	ES PNP	NPN	ES compl. with 5 m cable		Adapter only for OSP-P10)
			Type:	Type:	Type:	Type:	Type:	Type:	
OSP-P10	–	–	RS-K KL3045	RS-K KL 3048	ES-S KL 3054	ES-S KL 3060	ES-S 10750	ES-S 10751	20968 please order separately
OSP-P16	20	20.5							
OSP-P25	25	27							
OSP-P32	31	34							
OSP-P40	36	39							
OSP-P50	43	48							
OSP-P63	53	59							
OSP-P80	66	72							
Cable 5 m with connector and with open end for magnetic switches Type ES-S					4041				

Linear Drive Accessories

∅ 16-80 mm
Cable Cover

For clean guidance of magnetic switch cables along the cylinder body.
Contains a maximum of 3 cables with diameter 3 mm.
Material: Plastic
Colour: Red
Temperature Range: -10 to +80°C

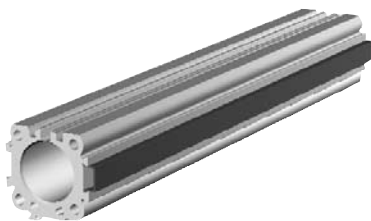

Dimensions (mm)

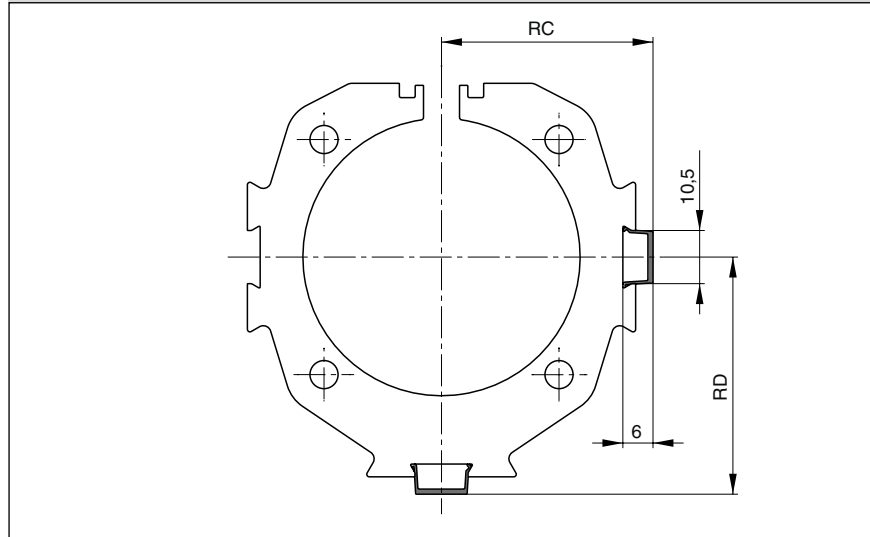

Dimension Table (mm) and Order Instructions

Series	Dimensions (mm)		Order No.
	RC	RD	
OSP-P16	18.5	19	13039 Minimal length: 1m Max. profile length: 2m Multiple profiles can be used.
OSP-P25	23.5	25.5	
OSP-P32	29.5	32	
OSP-P40	34.5	37.5	
OSP-P50	41.5	46.5	
OSP-P63	51.5	57.5	
OSP-P80	64.5	70.5	

P-A1 P687E00HAE00X

The right to introduce technical modifications is reserved

Characteristics			
Characteristics	Unit	Description	
Electrical Characteristics		Type RST	Type EST
Switching output		Reed	PNP
Operating voltage	V	10-30 AC/DC	10-30 DC
Ripple		-	≤10%
Voltage drop	V	≤3	≤2
Electrical configuration		2 wire	3 wire
Output function		normally open normally closed	normally open
Permanent current	mA	≤ 100	≤ 100
Breaking capacity	W	≤ 6 peak	-
Power consumption, at $U_B=24V$, switched on, without load	mA	-	≤ 10
Function indicator		LED, yellow (not for normally closed)	
Response time	ms	≤2	≤0.5
Sensitivity	mT	2–4	2–4
Time delay before availability	ms	-	≤2
Reverse polarity prot.		yes	yes
Short-circuit protection		no	yes (pulsed)
Switchable capacity load	μF	0.1 at 100 Ω, 24 VDC	
Switching frequency	Hz	≤400	≤5 k
Repeatability	mm	≤0.2	≤0.2
Hysteresis	mm	≤1.5	≤1.5
EMC	EN	60947-5-2	
Lifetime		≥35 Mio. cycles with PLC load	unlimited
Power-up pulse suppression		-	yes
Protection for inductive load		-	yes
Mechanical Characteristics			
Housing		Plastic / PA66 + PA6I red	
Cable cross section	mm ²	2 x 0.14	3 x 0.14
Cable type		PUR, black	PUR, black
Bending radius	mm	≥36	≥30
Weight	kg	ca. 0.030 RST-K ca. 0.010 RST-S	ca. 0.030 EST-K ca. 0.010 EST-S
Degree of protection	IP	67 to EN 60529	
Ambient temperature range ¹⁾	°C	-25 to +80	-25 to +75 at $U_B=10 - 30 V$ -25 to +80 at $U_B=10 - 28 V$
– with adapter	°C	-25 to +60	
Adapter tightening torque	Nm	0.15 (tightening torque of screwing adapter on to magnetic switch)	
Shock resistance			
Vibration to EN 60068-2-6	G	15, 11 ms, 10 to 55 Hz, 1 mm	
Shock to EN 60068-2-27	G	50, 11 ms	
Bump to EN 60068-2-29	G	30, 11 ms, 1000 bumps each axis	
For linear drives see P-1.10.002E			

Linear Drive Accessories

∅ 10-80 mm
Magnetic Switches

OSP
— ORIGA
— SYSTEM
— PLUS

Series **RST**
EST

Magnetic switches are used for electrical sensing of the position of the piston, e.g. at its end positions. They can also be used for sensing of intermediate positions.

Sensing is contactless, based on magnets which are built-in as standard. A yellow LED indicates operating status.

The universal magnetic switches are suitable for all Parker Origa OSP-Actuators and aluminum profile rod type cylinders.

¹⁾ for the magnetic switch temperature range, please take into account the surface temperature and the self-heating properties of the linear drive.



Type RST

In the type RST contact is made by a mechanical **reed switch** encapsulated in glass.

Type EST

In the type EST contact is made by an **electronic switch** – without bounce or wear and protected from pole reversal. The output is short circuit proof and insensitive to shocks and vibrations. Connection is by 3-pole connector for easy disconnection. Fitted with connection cable 100 mm long with connector. A 5 m cable with connector and open end can be ordered separately, or use the Order No. for the complete Type ES with 5 m cable.

Magnetic Switches RST and EST

Electrical Service Life Protective Measures

Magnetic switches are sensitive to excessive currents and inductions. With high switching frequencies and inductive loads such as relays, solenoid valves or lifting magnets, service life will be greatly reduced.

With **resistive and capacitive loads** with high switch-on current, such as light bulbs, a protective resistor should be fitted. This also applies to long cable lengths and voltages over 100 V.

In the switching of inductive loads such as relays, solenoid valves and

lifting magnets, voltage peaks (transients) are generated which must be suppressed by protective diodes, RC loops or varistors.

Connection Examples

- Load with protective circuits
 (a) Protective resistor for light bulb
 (b) Freewheel diode on inductivity
 (c) Varistor on inductivity
 (d) RC element on inductivity

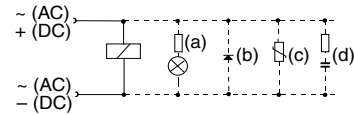

For the type EST, external protective circuits are not normally needed.

Electrical Connection Type RST-K

Normally closed

Normally open

Electrical Connection Type EST-K

Electrical Connection Type RST-S

Electrical Connection Type EST-S

Dimensions (mm) – Type RST-K, EST-K

* Cable lengths available: 5000 mm ± 75 mm
2000 mm ± 40 mm

** Switching point: Type RST-K Normally closed 14 mm
Type RST-K Normally open 12.3 mm
Type EST-K Normally open 8.1 mm

Dimensions (mm) – Type RST-S, EST-S

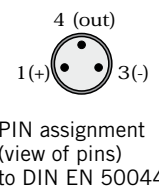
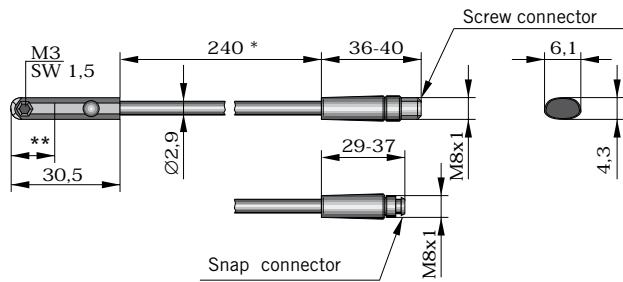

* ± 6 mm
 ** Switching point: Type RST-K Normally closed 14 mm
 Type RST-K Normally open 12.3 mm
 Type EST-K Normally open 8.1 mm

Installation

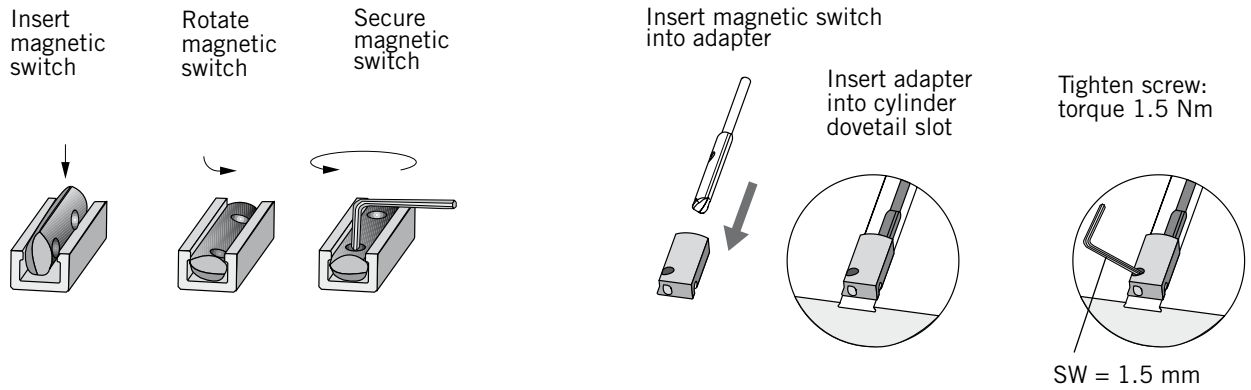

Dimensions adapters for RST/EST magnetic switch – for type OSP-P10

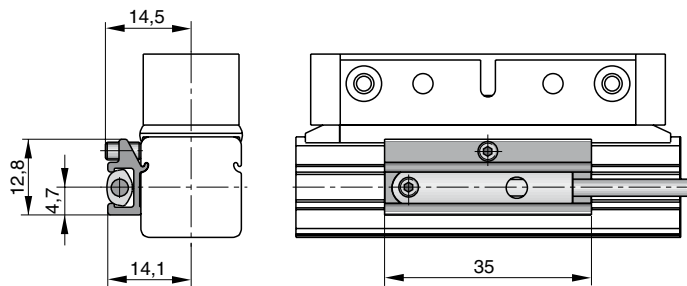

Dimensions adapters for RST/EST magnetic switch – for type OSP-P16 – 80

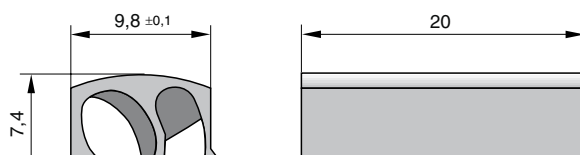

Order Instructions			
Version	Voltage	Type	Order No.
Magnetic switch, reed contact, normally open, LED indicator, cable 2 m	10-30 V AC / DC	RST-K	KL 3301
Magnetic switch, reed contact, normally open, LED indicator, cable 5 m	10-30 V AC / DC	RST-K	KL 3300
Magnetic switch, reed contact, normally open, snap connector M8, LED indicator, cable 0.24 m	10-30 V AC / DC	RST-S	KL 3302
Magnetic switch, reed contact, normally open, screw connector M8, LED indicator, cable 0.24 m	10-30 V AC / DC	RST-S	KL 3303
Magnetic switch, reed contact, normally closed, cable 5 m	10-30 V AC / DC	RST-K	KL 3305
Magnetic switch, electronic, PNP LED indicator, cable 2 m	10-30 V DC	EST-K	KL 3308
Magnetic switch, electronic, PNP LED indicator, cable 5 m	10-30 V DC	EST-K	KL 3309
Magnetic switch, electronic, PNP snap connector M8, LED indicator	10-30 V DC	EST-S	KL 3312
Magnetic switch, electronic, PNP screw connector M8, LED indicator	10-30 V DC	EST-S	KL 3306

Included in delivery: 1 magnetic switch, 1 adapter for T-slot magnetic switch for type OSP-P16 – 80.

Note: When using T-nut magnetic switches with the OSP-P10, please order the adapter Order No. 8872 separately.

Accessories		
Description	Type	Order No.
Cable M8, 2.5 m without lock nut	KS 25	KY 3240
Cable M8, 5.0 m without lock nut	KS 50	KY 3241
Cable M8, 10.0 m without lock nut	KS 100	KC 3140
Cable M8, 2.5 m with lock nut	KSG 25	KC 3102
Cable M8, 5.0 m with lock nut	KSG 50	KC 3104
Adapter for RST/EST magnetic switch – for type OSP-P10	HMTP010	8872
Adapter for RST/EST magnetic switch – for type OSP-P16 – 80 (pack of 10)		KL 3333

ORIGA-SENSOFLEX Displacement Measuring System for Cylinder Series OSP-P



Contents

Description	Data Sheet No.	Page
Overview	P-1.50.001E	117-118
Technical Data SFI-plus	P-1.50.002E-1, 2	119-120
Dimensions SFI-plus	P-1.50.002E-2	120
Order Instructions SFI-plus	P-1.50.002E-3	121

ORIGA- Sensoflex

Displacement measuring system
for automated movement

Series SFI-plus
(incremental measuring system)

for cylinder series

- OSP-P...

Characteristics

- Contactless magnetic displacement measurement system
- Displacement length up to 32 m
- Resolution 0.1 mm (option: 1 mm)
- Displacement speed up to 10 m/s
- For linear and non-linear rotary motion
- Suitable for almost any control or display unit with a counter input

For further specifications,
see P-1.50.002E



The SFI-plus magnetic displacement measuring system consists of 2 main components.

- **Measuring Scale**
Self-adhesive magnetic measuring scale

- **Sensing Head**
Converts the magnetic poles into electrical signals which are then processed by counter inputs downstream (e.g. PLC, PC, digital counter)

A3P108E00HAA00X

The right to introduce technical
modifications is reserved

Characteristics			
Characteristics	Unit	Description	
Type		21210	21211
Output Function			
Resolution	mm	0.1	1
Pole lengths magnetic scale	mm	5	
Maximum speed	m/s	10	
Repeat accuracy		± 1 Increment	
Distance between sensor and scale	mm	≤ 4	
Tangential deviation		≤ 5°	
Lateral deviation	mm	≤ ± 1.5	
Switching output		PNP	
Electrical Characteristics			
Operating voltage U_b	V DC	18 – 30	
Voltage drop	V	≤ 2	
Continuous current for each output	mA	≤ 20	
Power consumption at $U_b = 24V$, switched on, without load	mA	≤ 50	
Short-circuit protection		yes	
Reverse polarity protection		yes	
Protection from inductive load		yes	
Power-up pulse suppression		yes	
EMC			
Electrostatic discharge immunity	kV	6, B, to EN 61000-4-2	
Electromagnetic field immunity	V/m	10, A, to EN61000-4-3	
Electrical fast transient/burst immunity (for signal connections)	kV	1, B, to EN 61000-4-4	
Electrical fast transient/burst immunity (for DC connections)	kV	2, B, to EN 61000-4-4	
Surge immunity (for signal connections)	kV	1, B, to EN 61000-4-5	
Surge immunity (for DC connections)	kV	0,5, B, to EN 61000-4-5	
Immunity to conducted disturbances	V	10, A, to EN 61000-4-6	
Power frequency magnetic field immunity at 50 Hz	A/m	30, A, to EN 61000-4-8	
Emission standard for residential		to EN 61000-6-4	
Radio disturbance characteristics		to EN 55011, Group 1, A	
Mechanical Characteristics			
Housing		Aluminium	
Cable length	m	5.0 – fixed, open end	
Cable cross section	mm ²	4 x 0.14	
Cable type		PUR, black	
Bending radius	mm	≥ 36	
Weight (mass)	kg	ca. 0.165	
Environmental Conditions / Shock Resistance			
Degree of protection	IP	67 to EN60529	
Ambient temperature range	°C	-25 to +80	
Broad-band random vibration to EN 60068-2-64	g	5, 5 Hz to 2 kHz, 0.5 h each axis	
Vibration stress to EN 60068-2-6	g	12, 10 Hz to 2 kHz, 2 mm, 5 h each axis	
Shock to EN 60068-2-27	g	100, 6 ms, 50 bumps each axis	
Bump to EN 60068-2-29	g	5, 2 ms, 8000 bumps each axis	

For **Overview** see P-1.50.001

Displacement measuring system

for automated movement

ORIGA-Sensoflex
(incremental displacement measuring system)

Series SFI-plus
for cylinder series
• OSP-P...

Note:

For combinations Active Brake AB + SFI-plus + Magnetic Switch contact our technical department please.



Order instructions	
Description	Order No.
Sensing head with measuring scale – Resolution 0.1 mm (scale length = required measuring distance + a minimum of – see table below)	21240
Option: Sensing head with measuring scale – Resolution 1 mm (scale length = required measuring distance + a minimum of – see table below)	21241
Sensing head – Resolution 0.1 mm (spare part)	21210
Option: Sensing head – Resolution 1 mm (spare part)	21211
Measuring scale per meter (spare part)	21235
Mounting kit for OSP-P25	21213
Mounting kit for OSP-P32	21214
Mounting kit for OSP-P40	21215
Mounting kit for OSP-P50	21216
Mounting kit for OSP-P63	21217
Mounting kit for OSP-P80	21218

* Overall length of the measuring scale results from stroke length of the cylinder + dead length
Dead length for linear drives series OSP-P see table.

Series	Dead length (mm)
OSP-P 25	154
OSP-P 32	196
OSP-P 40	240
OSP-P 50	280
OSP-P 63	350
OSP-P 80	422

Example:

Cylinder OSP-P, Ø25 mm, stroke length 1000 mm

dead length + stroke length = overall length of the measuring scale
154 mm + 1000 mm = 1154 mm

Information on application

The contents of this catalog are not binding and are only intended for informational purposes and are not to be considered as offer with legal effect. A written confirmation of order from Parker Origa is authoritative for the conclusion of a contract; this confirmation is given solely under the respective currently applicable Parker Origa General Terms of Sale and Delivery. These are included in our price list and in the Internet at www.parker-origa.com.

All the products presented in this catalog are purely for commercial use. None of the information or contents is appropriate for private consumers. Private consumers cannot place orders based on the information in the catalog. Please contact Parker Origa for further information.

All the products listed in this catalog are designed for typical pneumatic applications which e.g. are installed in higher-level machines. The recognized technical rules for safe and expert work are to be observed for the use and installation of pneumatic products. The precondition for the use of the products is, unless stated otherwise, correctly prepared compressed air free from aggressive media. Furthermore, the respective regulations of the legislator, the TÜV (Technical Inspection Association), the respective professional associations or the VDE (Association of Electrical, Electronic and Information Technologies) provisions also apply.

The technical data stated in this catalog is to be observed by the user. The data stated may not be exceeded nor fallen short of. If such data is not stated then it may be assumed that there are no such upper or lower limits or restrictions for particular applications. In the case of unusual physical or chemical applications, consultation and clearances are to be obtained from Parker Origa

Unless otherwise agreed in individual cases, the customer or end consumer is responsible for the disposal of the ORIGA products. Disposal by Parker Origa is not included in the price and this would have to be taken into account in the event of any applicable return to and disposal by Parker Origa.

Technical data and representations

The technical data and illustrations have been compiled with great care and to the best of our knowledge. We cannot assume any guarantee for the up-to-dateness, correctness and completeness of the information.

The data and information such as illustrations, drawings, descriptions, dimensions, weights, materials, technical and other performances as well as the products and services described in general product descriptions, Parker Origa catalogs, brochures and price lists of any type are subject to change and may be modified or updated at any time without prior announcement by Parker Origa. They are only binding in so far as the contract or confirmation of order expressly refers to them. Slight deviations from such product descriptions are deemed as approved and do not affect the fulfillment of contracts in so far as these are considered acceptable to customers.

This catalog does not contain any guarantees, assured characteristics or agreements on condition by Parker Origa for the products represented, neither expressly nor implicitly, nor with regard to the availability of the products. Advertising statements regarding quality characteristics, properties or applications of ORIGA products are without legal obligation.

As far as legally permissible, any liability is excluded on the part of Parker Origa for direct or indirect damage, consequential damage, claims of any type and on any legal basis arising from the use of the information contained in this catalog.

Trademarks, copyright and reproduction

The representation of industrial rights such as brands, logos, registered trademarks or patents in this catalog does not include the granting of licenses or rights of use. The use of these is not permitted without the express consent of Parker Origa. The entire contents of this catalog are the intellectual property of Parker Origa. Within the meaning of copyright, any unlawful use of intellectual property, even extracts, is prohibited. Reprinting, reproduction and translation (even extracts) are only permitted with the prior written consent of Parker Origa.

Importance of EU Directives

Various Directives have been issued by the EU Commission in the course of the unification of the single European market; the following Directives are in part of significance for ORIGA products:

- Simple pressure vessels (87/404/EWG, amended by 90/488/EWG and 93/68/EWG)
- Low-voltage electrical equipment (73/23/EWG, amended by 93/68/EWG)
- Machinery Directive (89/392/EWG, amended by 91/368/EWG, 93/44/EWG and 98/37/EG)
- Pressure Equipment Directive (97/23/EWG)
- Equipment and protective systems intended for use in potentially explosive atmospheres (ATEX Directive, 94/9/EG)
- Electromagnetic Compatibility Directive (EMV Directive, 89/336/EWG, amended by 92/31/EWG)

If a product comes within the scope of application of one of these Guidelines, then an EU Declaration of Conformity with CE mark (CE for Communauté Européenne) is required. This CE marking does not represent a quality feature but verifies that the conformity assessment procedure specified has been concluded successfully and the protective requirements of the relevant EU Directives have been observed.

Products which do not come under any of the above mentioned Directives may not bear the CE mark nor may any manufacturer's declaration according to the EU Machinery Directive or Declaration of Conformity be issued for these products.

If a product may not be CE marked according to the Machinery Directive, it must however be marked if it comes within the scope of application of any other Directive.

The following harmonized standards are applied in the design of ORIGA components and systems:

- DIN EN ISO 12100 Safety of machinery
- DIN EN 60204.1 Electrical equipment of machines
- DIN EN 983 Safety requirements for fluid power systems and their components

The following Directives are of particular significance to Parker Origa:

- ORIGA products in potentially explosive atmospheres, to which the above mentioned ATEX Directive applies, are treated according to the Directive and CE and EX marked.
- According to the Machinery Directive, ORIGA products are mainly components for installation in machines and therefore do not require an EU Declaration of Conformity with CE mark. Parker Origa-ORIGA issues a manufacturer's declaration according to the Machinery Directive for these components. This declaration corresponds to a great extent to the Declaration of Conformity with the comment that commissioning is only permitted if the machine or system conforms to the Directives. This manufacturer's declaration impacts neither our product liability based on the product liability law nor warranty assurances according to our General Terms of Sale and Delivery. Neither does the manufacturer's declaration affect our quality assurance measures according to our Quality Management Manual nor our quality certification according to ISO 9001.
- According to the Pressure Equipment Directive, ORIGA products are components of low hazard potential, thus most of the products do not come under this Directive. The exceptions to this are maintenance equipment from a certain pressure/volume level onwards. These components are treated according to the Directive if required and bear the CE mark.

ORIGA products are excluded from the following EU Guidelines:

- End-of-life vehicles (2000/53/EG).
- Waste Electronic and Electrical equipment (WEEE, 2002/96/EG) and Restriction on Hazardous Substances (RoHS, 2002/95/EG).
- Pressure Equipment Directive (97/23/EWG) with the above mentioned exceptions.

Sales Offices Worldwide

AE – United Arabien Emirates

Dubai
Tel: +971 4 8875600
parker.me@parker.com

AR – Argentina, Buenos Aires
Tel: +54 3327 44 4129**AT – Austria**, Wiener Neustadt
Tel: +43 (0)2622 23501-0
parker.austria@parker.com**AT – Austria**, Wiener Neustadt
(Europa Oriental)
Tel: +43 (0)2622 23501 970
parker.easteurope@parker.com**AT – Austria**, Wiener Neustadt
Parker Origa Pneumatik GmbH
Tel: +43 2622 26071-269
info-hoat-sales.pn@parker-origa.com**AU – Australia**, Castle Hill
Tel: +61 (0)2-9634 7777**AZ – Azerbaijan**, Baku
Tel: +994 50 2233 458
parker.azerbaijan@parker.com**BE/LX – Belgium**, Nivelles
Tel: +32 (0)67 280 900
parker.belgium@parker.com**BR – Brazil**, Cachoeirinha RS
Tel: +55 51 3470 9144**BY – Belarus**, Minsk
Tel: +375 17 209 9399
parker.belarus@parker.com**CA – Canada**, Milton, Ontario
Tel: +1 905 693 3000**CH – Swiss**, Etoy
Tel: +41 (0) 21 821 02 30
parker.switzerland@parker.com**CH – Swiss**, Otelfingen
Parker Origa AG
Tel: +41 44 846 6860
info-hoch-sales@parker-origa.com**CN – China**, Shanghai
Tel: +86 21 5031 2525**CZ – Czechia**, Klecany
Tel: +420 284 083 111
parker.czechrepublic@parker.com**DE – Germany**, Kaarst
Tel: +49 (0)2131 4016 0
parker.germany@parker.com**DK – Denmark**, Ballerup
Tel: +45 43 56 04 00
parker.denmark@parker.com**ES – Spain**, Madrid
Tel: +34 902 33 00 01
parker.spain@parker.com**FI – Finland**, Vantaa
Tel: +358 (0)20 753 2500
parker.finland@parker.com**FR – France**
Tel: +33 (0)4 50 25 80 25
parker.france@parker.com**FR – France**, Courtaboeuf Cedex
Parker Origa SAS
Tel: +33 1 69 29 22 00
info-hofr-sales@parker-origa.com**GR – Greece**, Atenas
Tel: +30 210 933 6450
parker.greece@parker.com**HK – Hong Kong**
Tel: +852 2428 8008**HU – Hungary**, Budapest
Tel: +36 1 220 4155
parker.hungary@parker.com**IE – Ireland**, Dublin
Tel: +353 (0)1 466 6370
parker.ireland@parker.com**IN – India**, Mumbai
Tel: +91 22 6513 7081-85**IT – Italy**, Corsico (MI)
Tel: +39 02 45 19 21
parker.italy@parker.com**IT – Italy**, Pioltello (MI)
Parker Origa SRL
Tel: +39 02 92 16 65 53
info-hoit-sales@parker-origa.com**JP – Japan**, Fujisawa
Tel: +(81) 4 6635 3050**KR – Korea**, Seoul
Tel: +82 2 559 0400**KZ – Kazakhstan**, Almaty
Tel: +7 7272 505 800
parker.easteurope@parker.com**LV – Latvia**, Riga
Tel: +371 6 745 2601
parker.latvia@parker.com**MX – Mexico**, Apodaca
Tel: +52 81 8156 6000**MY – Malaysia**, Subang Jaya
Tel: +60 3 5638 1476**MY – Malaysia**, Penang
Parker Origa Sdn Bhd
Tel: +60 4 508 10 11
info-hosg-sales@parker-origa.com**NL – Netherlands**, Oldenzaal
Tel: +31 (0)541 585 000
parker.nl@parker.com**NL – Netherlands**, SL Moerdijk
Parker Origa B.V.
Tel: +31 168 356 600
info-honl-sales@parker-origa.com**NO – Norway**, Ski
Tel: +47 64 91 10 00
parker.norway@parker.com**NO – Norway**, Drammen
Parker Origa AS
Tel: +47 3 288 08 40
info-hose-sales@parker-origa.com**NZ – New Zealand**
Mt Wellington
Tel: +64 9 574 1744**PL – Poland**, Varsovia
Tel: +48 (0)22 573 24 00
parker.poland@parker.com**PT – Portugal**, Leca da Palmeira
Tel: +351 22 999 7360
parker.portugal@parker.com**RO – Romania**, Bucarest
Tel: +40 21 252 1382
parker.romania@parker.com**RU – Russia**, Moscow
Tel: +7 495 645-2156
parker.russia@parker.com**SE – Sweden**, Spånga
Tel: +46 (0)8 59 79 50 00
parker.sweden@parker.com**SE – Sweden**, Kungsör
Parker Origa AB
Tel: +46 227 411 00
info-hose-sales@parker-origa.com**SG – Singapor**
Tel: +65 6887 6300**SG – Singapor**
Parker Origa PTE Ltd.
Tel: +65 6483 2959
info-hose-sales@parker-origa.com**SK – Slovakia**, Banská Bystrica
Tel: +421 484 162 252
parker.slovakia@parker.com**SI – Slovenia**, Novo Mesto
Tel: +386 7 337 6650
parker.slovenia@parker.com**TH – Thailand**, Bangkok
Tel: +662 717 8140**TR – Turkey**, Istanbul
Tel: +90 216 4997081
parker.turkey@parker.com**TW – Taiwan**, Taipei
Tel: +886 2 2298 8987**UA – Ukraine**, Kiev
Tel: +380 44 494 2731
parker.ukraine@parker.com**UK – United Kingdom**, Gloucester
Parker Origa Ltd.
Tel: +44 8700 600655
info-hogb-sales@parker-origa.com**UK – United Kingdom**, Warwick
Tel: +44 (0)1926 317 878
parker.uk@parker.com**US – United States of America**,
Cleveland
Tel: +1 216 896 3000**US – United States of America**
Parker Origa Corporation
Tel: +1 630 871 830-0
info-hous-sales@parker-origa.com**VE – Venezuela**, Caracas
Tel: +58 212 238 5422**ZA – South Africa**,
Kempton Park
Tel: +27 (0)11 961 0700
parker.southafrica@parker.com**Parker-Origa GmbH**

Industriestr. 8
70794 Filderstadt, Deutschland
Tel. +49 7185 17030
Fax +49 7158 64870
www.parker-origa.com

