

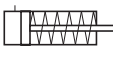







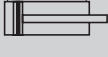

Overview

System	Fig.	Symbol	Series	Page
Single acting without cushioning			R3...	16-19 21
Double acting without cushioning For contactless position sensing			R6...	16-19 21
Double acting with cushioning			R1...	16-19 21
Double acting with cushioning For contactless position sensing			R5...	16-19 21
With through piston rods Double acting without cushioning For contactless position sensing			RDU6...	16-19 21
Non-rotating Double acting with cushioning For contactless position sensing			RDV5...	16, 17 20, 21

**Standard
Cylinders**

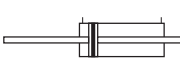
*Basic cylinder
to ISO 6432
CETOP RP 52P*

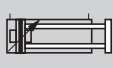
*Series R...
Series RDU...
Ø 10-25 mm*

*Basic cylinder
non-rotating*

*Series RDV...
Ø 25 mm*

Round cylinder Ø 10-25 mm

to ISO 6432
CETOP RP 52P

Series R...

System:

- single acting
- double acting without cushioning
- double acting with cushioning
- for contactless position sensing
- ATEX-Version 
- with through piston rod
- non-rotating

Universal cylinder mountable to the front and rear cylinder end caps by means of a thread. Pivot mounted on the rear cylinder covers.

The delivery includes:

- 1 Cylinder
- 1 Hexagon nut for piston rod thread and cylinder mounting

Versions without contactless position sensing on request

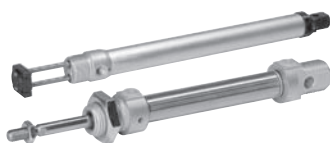

Characteristics

Characteristics	Symbol	Unit	Description					
General Features								
Type			Basic cylinder					
Series			R..., RDU..., RDV...					
System								
R3...			Single acting without cushioning					
R6...			Double acting without cushioning					
R1..., R5...			Double acting with cushioning					
RDU6...			With through piston rod Double acting without cushioning					
RDV5...			Non-rotating Double acting with cushioning					
Ambient temperature range	T_{min} T_{max}	°C	-10					
		°C	+70	Note: When using below freezing point (°C), please contact us for advice				
Medium temperature range	T_{max}	°C	+70					
Weight (mass)		kg	See table					
Medium			Filtered and lubricated or filtered unlubricated compressed air					
Lubrication			Oil mist lubrication compatible with Buna N					
Material								
Cylinder barrel			Steel, high-alloy					
Front/rear end caps			Aluminium					
Piston rod			Steel, high-alloy					
Pneumatic Characteristics								
Nominal pressure	p_n	bar	6					
Series			R..., RDU					
Piston diameter		mm	10	12	16	20	25	25
Operating pressure range	p_{min} p_{max}	bar bar	1,5 10	1 10				1 10
Port size			M5	M5	M5	G1/8	G1/8	G1/8
Piston rod diameter		mm	4	6	6	8	10	6
Stroke length		mm	For standard stroke lengths see order instructions, max. 50 (R 3...), max. 500 (R 5..., R 6...) longer strokes on request					
Cushioned stroke		mm	-	-	-	17	17	17
Piston force and air consumption			see page 9					
Compression force at 6 bar		N	265					
Tensile force at 6 bar		N	235					

Weight (mass) kg

Mounting	Cylinder diameter									
	Ø10		Ø12		Ø16		Ø20		Ø25	
	1*	2*	1*	2*	1*	2*	1*	2*	1*	2*
Basic cylinder Type R....	0.065	0.025	0.120	0.040	0.135	0.050	0.260	0.070	0.350	0.080
With through piston rod Type RDU....	0.100	0.045	0.155	0.060	0.170	0.070	0.330	0.110	0.460	0.170
Non-rotating Type RDV....	-	-	-	-	-	-	-	-	0.460	0.110

Mounting	Cylinder diameter				
	Ø10	Ø12	Ø16	Ø20	Ø25
RA (1 bracket)	0.022	0.043	0.043	0.100	0.100
RC	0.013	0.028	0.028	0.050	0.050
RB	0.023	0.036	0.036	0.080	0.080

* 1 = Weight for cylinder with 100 mm stroke
2 = Weight for every additional 100 mm stroke length

**Theoretical Spring Return Forces in relation to Stroke Length
Series R3..., R5..., R6...**

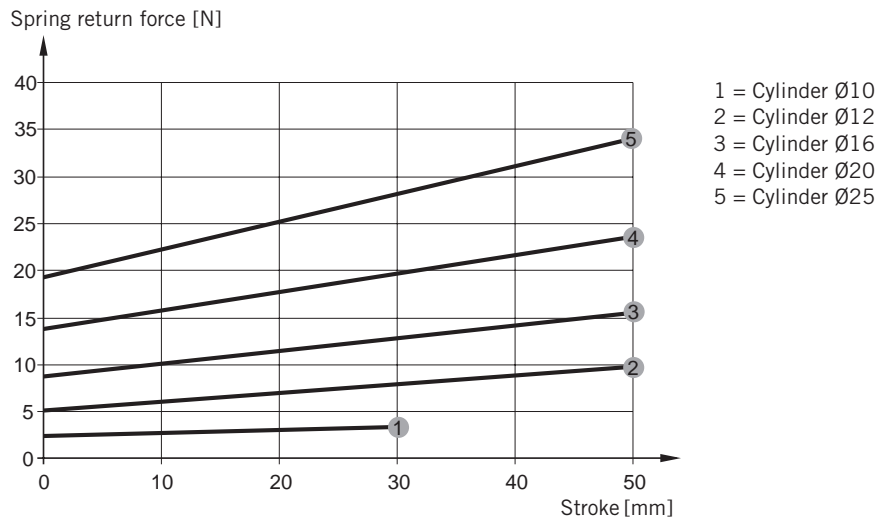

Piston force and air consumption see page 9, dimensions see page 18-20, order instructions see page 21

**Dimensions – Basic Cylinder, Single Acting, Ø 10 – 25 mm
Series R3...**

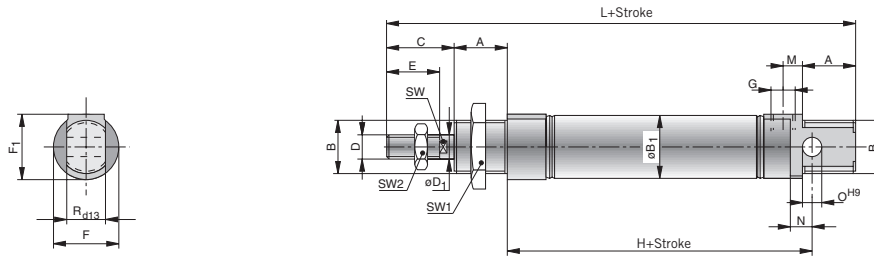

**Dimensions – Basic Cylinder, Double Acting, Ø 10 – 25 mm
Series R5..., R6..., R1...**

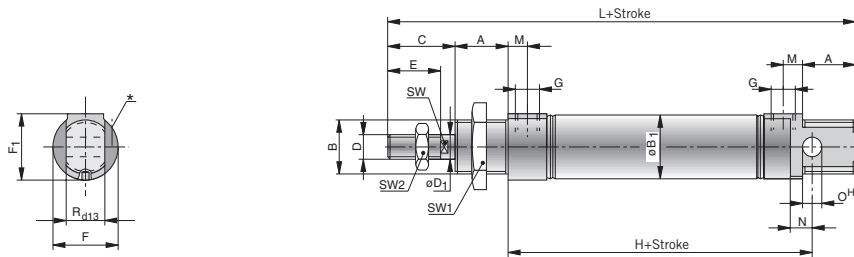

*From the connection side: adjustable end cushioning only for types R 5016, R 5020, R 5025

**Dimensions – Basic Cylinder, Double Acting with through piston rod
Series RDU6...**

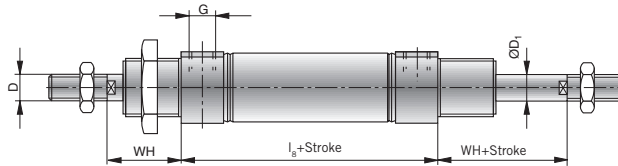

for further dimensions see Series R5....

Dimension Table (mm) for Basic Cylinder, Series R..., RDU....

Cyl.Ø	A	B	ØB ₁	C	D	ØD ₁	E	F	F ₁	G	H + Stroke	I _s + Stroke
10	12	M12x1.25	11.3	16	M4	4	12	15	15	M5	48	44.5
12	17	M16x1.5	13.3	21	M6	6	16	20	20	M5	53	46
16	17	M16x1.5	17.3	21	M6	6	16	20*	20*	M5	60	56
20	20	M22x1.5	21.3	24	M8	8	20	27	27	G1/8	71	66
25	22	M22x1.5	26.5	28	M10x1.25	10	22	27	27	G1/8	76	69

* for Type R5016: F = 22, F₁ = 21

Cyl.Ø	L+ Stroke	M	N	ØH ⁹	R _{d13}	SW	SW ₁	SW ₂	WH	WH + Stroke
10	84	5	6	4	8	–	19	7	16	16
12	101	5	9	6	12	5	24	10	22	22
16	111	5	9	6	12	5	24	10	22	22
20	130	8	12	8	16	7	32	13	24	24
25	141	8	12	8	16	9	32	17	28	28

Mountings – Series R..., RDU..., Ø 10 – 25 mm

Dimensions Mounting RA

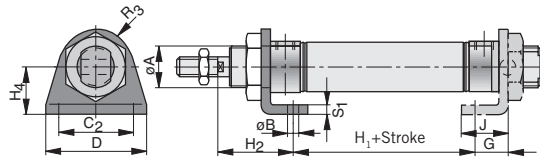

Material: steel, passivated

Dimension Table (mm) for Mounting RA

Cyl.- Ø	ØA	ØB	C ₂	D	G	H ₁ + Stroke	H ₂	H ₄	J	R ₃	S ₁
10	12	4.5	25	35	11	30	24	16	16	10	3
12	16	5.5	32	42	14	29	32	20	20	13.5	4
16	16	5.5	32	42	14	36	32	20	20	13.5	4
20	22	6.6	40	54	17	44	36	25	25	18	5
25	22	6.6	40	54	17	45	40	25	25	18	5

Dimensions Mounting RC

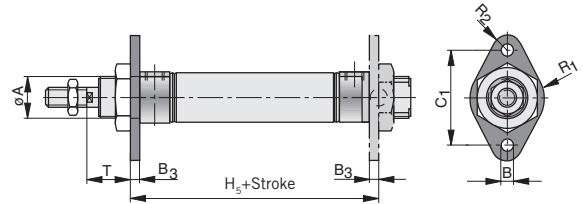

Material: steel, passivated

Dimension Table (mm) for Mounting RC

Cyl.- Ø	ØA	ØB	B ₃	C ₁	H ₅ + Stroke	R ₁	R ₂	T
10	12	4.5	3	30	52	12.5	5	13
12	16	5.5	4	40	58	15	6	18
16	16	5.5	4	40	64	15	6	18
20	22	6.6	5	50	78	20	8	19
25	22	6.6	5	50	79	20	8	23

Rear Trunnion Mounting RB

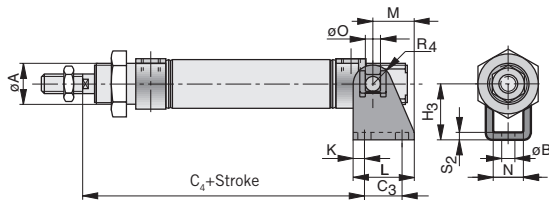

Material: steel, passivated

Dimension Table (mm) – for Mounting RB

Cyl. Ø	ØB	C ₃	C ₄ + Stroke	H ₃	K	L	M	N	ØO	R ₄	S ₂
10	4.5	12.5	65	24	6.5	23	18	8.1	4	5	2.5
12	5.5	15	73	27	5	25	18	12.1	6	7	3
16	5.5	15	80	27	5	25	18	12.1	6	7	3
20	6.6	20	91	30	6	32	22	16.1	8	10	4
25	6.6	20	100	30	6	32	22	16.1	8	10	4

Mountings – Series RDU....

Mounting RA2... (2 brackets)

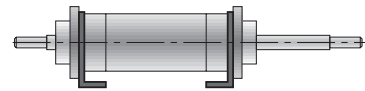

Mounting RA1.. (1 bracket)

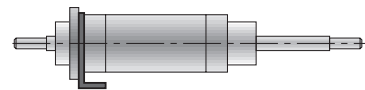

Mounting RC... (1 flange)

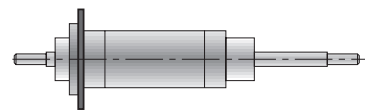

Mountings - Accessories



Piston force and air consumption see page 9, dimensions see page 18-20, order instructions see page 21

**Dimensions – Double acting, non-rotating, Ø 25 mm
Series RDV5...**

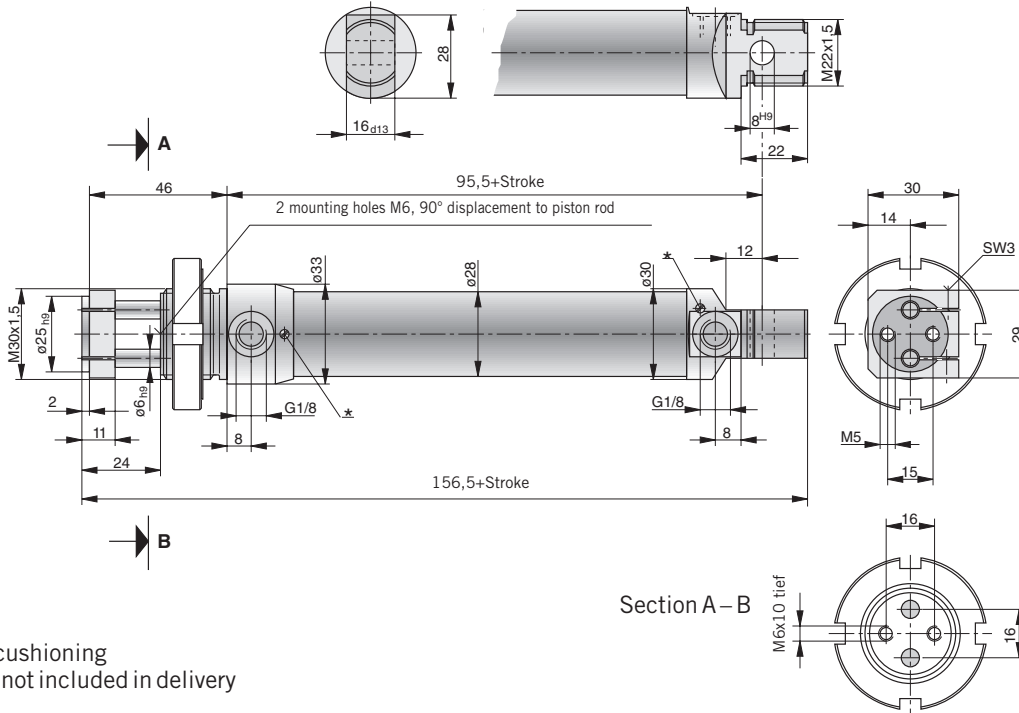

* adjustable end cushioning
Mounting nut is not included in delivery

Mounting instruction:
When mounting the front plate onto the piston rods tighten the screws with a torque $M_a = 4 \text{ N}$.

Mountings – Series RDV...., Ø 25 mm

Dimensions (mm) – Mounting RA

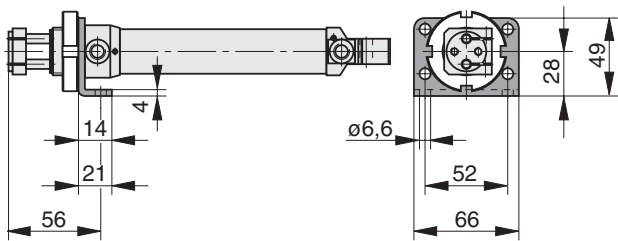

Material: steel, passivated

Dimensions (mm) – Mounting RB (counter bearing)

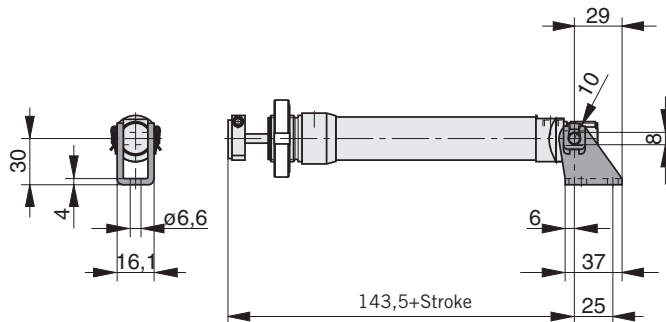

Material: steel, passivated

Mountings - Accessories

Magnetic Switch



Page 152

Magnetic Switch



Page 149



Piston force and air consumption see page 9, order instructions see page 21



HOERBIGER

Order Instructions – Basic Cylinder, Series R..., RDU..., RDV...

System	Symbol	Piston- Ø	Stroke Length	Order Instructions	
				Type	Order-No.
Single acting without cushioning		10	max. 25 ¹⁾	R3010/..	PA67410-....
		12	max. 50 ²⁾	R3012/..	PA67430-....
		16	max. 50 ²⁾	R3016/..	PA67450-....
		20	max. 50 ²⁾	R3020/..	PA67470-....
		25	max. 50 ²⁾	R3025/..	PA67500-....
Double acting without cushioning For contactless position sensing		10	max. 100 ³⁾	R6010/..	PA67420-....
		12	max. 200 ³⁾	R6012/..	PA67440-....
		16	max. 200 ³⁾	R6016/..	PA67460-....
		20	max. 320 ³⁾	R6020/..	PA67490-....
		25	max. 500 ³⁾	R6025/..	PA67520-....
Double acting with cushioning		16	max. 200 ³⁾	R1016/..	PA68400-....
		20	max. 320 ³⁾	R1020/..	PA67570-....
		25	max. 500 ³⁾	R1025/..	PA67590-....
Double acting with cushioning For contactless position sensing		16	max. 200 ³⁾	R5016/..	PA68410-....
		20	max. 320 ³⁾	R5020/..	PA67480-....
		25	max. 500 ³⁾	R5025/..	PA67510-....
With through rod piston Double acting without cushioning For contactless position sensing		10	max. 100 ³⁾	RDU6010/...	PA68420-....
		12	max. 200 ³⁾	RDU6012/...	PA67690-....
		16	max. 320 ³⁾	RDU6016/...	PA67700-....
		20	max. 500 ³⁾	RDU6020/...	PA67710-....
		25	max. 500 ³⁾	RDU6025/...	PA67720-....
Non-rotating Double acting with cushioning For contactless position sensing		25	max. 500 ³⁾	RDV5025/...	PA50470-....

Complete type designation and order no. with stroke length (in mm)

Standard stroke length:

¹⁾ 0010, 0025

²⁾ 0010, 0025, 0050

³⁾ 0025, 0050, 0080, 0100, 0125, 0160, 0200, 0250, 0320

(4-digit)

Mountings – Cylinder mounting parts and Accessories

Description	Order-No.					
	Type	Ø10	Ø12	Ø16	Ø20	Ø25
Foot mounting (1 mounting bracket)	RA 1-..	KX 9271	KK 26302	KK 26302	KK 28302	KK 28302
Foot mounting (standard version)	RA 2-..*	PD 31522	PD 25771	PD 25771	PD 25772	PD 25772
Flange mounting (1 flange)	RC- ..	KX 9272	KK 26305	KK 26305	KK 28305	KK 28305
Rear trunnion mounting	RB- ..**	KZ 1412	KZ 1419	KZ 1419	KZ 1420	KZ 1420
Foot mounting (1 mounting bracket) for series RDV5...	RA 1-32					KK29.302
Groove nut for series RDV5...						ZP2125

Complete type designation with piston-Ø

Example: RA 1-25 KK 28302

* consisting of 2 mounting brackets and 1 hexagonal nut

** consisting of 1 pivot with bolt and circlip

