

Overview

Description	Page		
	Characteristics	Dimensions	Order instructions Type overview
Drain valve (assembly kit)	114, 115	116	118
Drain valve G1/2, DV-1/2e	114, 115	116, 117	118
Drain valve G1/2, DV-1/2e2	114, 115	117	118
Float-type drain valve, electronically actuated, G3/4, DV-3/4e	114, 115	117	118

**Air preparation
units**

*Condensate manage-
ment airfit drain
G1/2, G3/4*



Air preparation units

Condensate management airfit drain
G1/2, G3/4

Characteristics

Special solutions
(e.g. temperature, pressure,
medium ...) on request

Pressures quoted as gauge pressure

Characteristics	Symbol	Unit	Drain valve DV-1/2i (DV1/4i)	Drain valve DV-1/2e
System			Float controlled condensate drain valve (automatic)	Float controlled condensate drain valve (automatic)
Port size			Assembly kit	G1/2
Material				
– Float controller			Plastic (PP black)	Stainless steel
– Housing			Plastic (PA)	Al
– Sealings			Oil resistant rubber	Oil resistant rubber
Condensate drainage			– During operation when reaching certain condensate level – During pressure relief – Manual	– During operation when reaching certain condensate level – Manual
Installation			Vertical	Horizontal (see sketch)
Mounting			In the bowl with a circlip or mounting nut M14x1	Double nipple
Weight (mass)		kg	0.06	0.65
Medium and ambient temperatures	T_{min} T_{max}	°C	2 70 (120 on request)	2 100
Condensate temperature	T	°C	–	–
Operating pressure range	p_{min} p_{max}	bar	1.5 20 (12 for DV-1/4i)	0 20
Performance characteristic for				
– Max. compressor capacity		m ³ /min	–	–
– Max. dryer capacity		m ³ /min	–	–
– Short-term peak condensate volume		l/h	–	–
Electrical connection self adjusting		V DC V AC	– –	– –
Power consumption		VA	–	–
Degree of protection		IP	–	–
Resistance-free contact		V AC/DC	–	–
Electronic relay (opens at failure)		A	–	–



Air preparation units

*Condensate management airfit drain
G1/2, G3/4*

Characteristics

Drain valve DV-1/2e2	Float controlled drain valve, DV-3/4
Float controlled condensate drain valve (fully automatic)	Electronically controlled condensate drain valve without air consumption
G1/2	G3/4 external thread or NPT 1/2
Plastic (PP black)	–
Aluminum, polycarbonate bowl	–
Oil resistant rubber	–
– During operation when reaching certain condensate level – During pressure relief – Manual	Level sensing, electronically controlled
Vertical (see sketch)	Vertical
Double nipple or direct	Direct
0.3	1.0
0	1
50 at 10 bar	60
–	max. 60
0	0.8
16	16
–	5
–	10
–	30 at 7 bar
–	24–230
–	80–230
–	5
–	65
–	max. 300
–	0.1



Air preparation units

Condensate management airfit drain G1/2

Dimensions

Drain valve DV-1/4i, DV-1/2i – Assembly kit

Float-controlled drain valve for automatic drainage of condensate from industrial filters used in compressed air technology.

For installation in all plastic and metal reservoirs. Fitted in the HOERBIGER A25 and A50 series.

Delivery includes:

Drain valve, with o-ring and locking device if required

Drain valve DV-1/2e

Float-controlled drain valve for automatic drainage of condensate from compressed air lines and compressors. Tackles highly polluted condensate without problems.

Installation instruction:

Generally at the lowest point, where condensate and oil collect.



Type: DV-1/2i

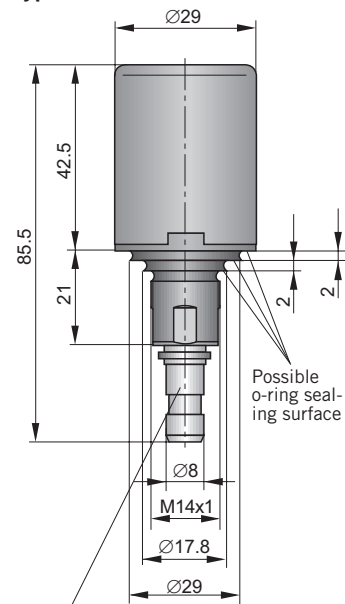

Connector for push-in fitting Ø 8

Type: DV-1/2i

– for series airfit A25, A50

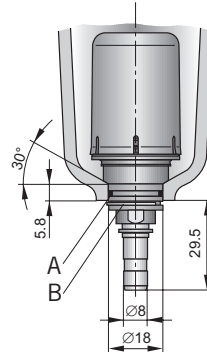

Installation instruction DV-1/2i

1. Lightly grease seal ring A before assembly.
2. Insert the drain valve into the bowl from the top.
3. Secure the drain valve outside the bowl with circlip B.

Type: DV-1/4i

– for series airfit swing

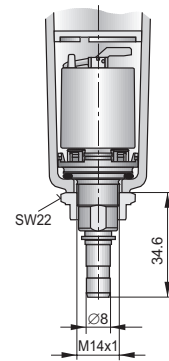

Type: DV-1/2e

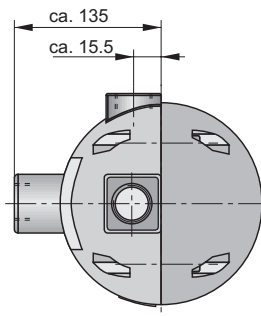
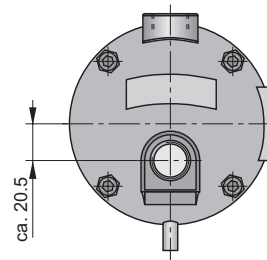
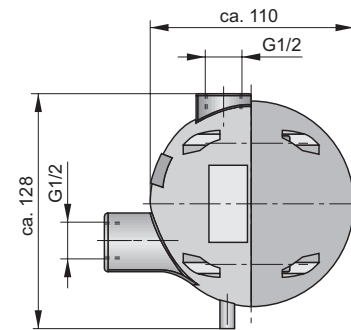

Installation instruction Type: DV-1/2e

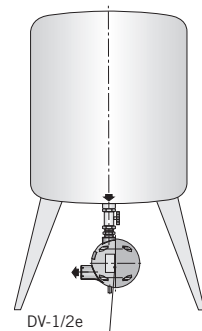
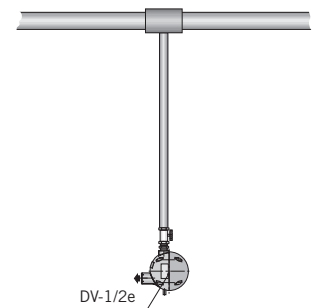

For order instructions see page 118, for characteristics see page 114, 115

Dimensions in mm

Condensate capacity – Type: DV-1/2e

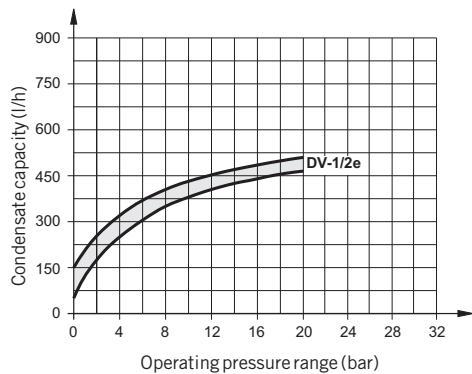

Type: DV-1/2e2

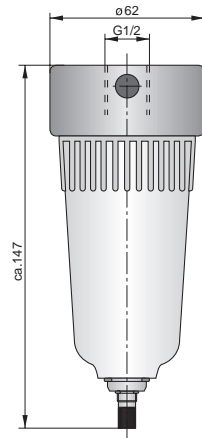

Installation instruction Type: DV-1/2e2

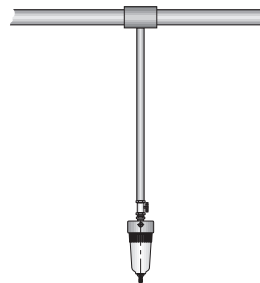

Air preparation units

Condensate management airfit drain G1/2

Dimensions

Drain valve DV-1/2e2

Float-type drain valve for fully automatic drainage of condensate from compressed air lines – for external mounting

Installation instruction: Generally at the lowest point, where condensate and oil collect.

Float controlled drain valve, electronically actuated DV-3/4

- For external application
- Level dependant control
- Universal voltage for international use
- Version for aggressive media

Installation instruction: Please note the instruction manual. Highly polluted condensate requires the use of a strainer (particle separation).

Type: DV-3/4e

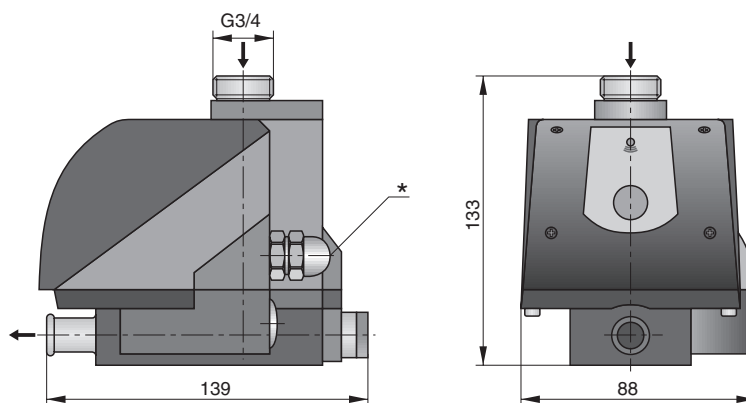

* Electronic connection PG9

For order instructions see page 118, for characteristics see page 114, 115

Dimensions in mm



Air preparation units

*Condensate management airfit drain
G1/4, G1/2, G3/4*

Order instructions

Order instructions

Description	Symbol	Port size	Order instruction	
			Type	Order No.
Drain valve, assembly kit, fully automatic condensate drainage			DV-1/4i	On request
Drain valve, assembly kit, fully automatic condensate drainage			DV-1/2i	PL 19560
Drain valve, fully automatic condensate drainage		G1/2	DV-1/2e	KG6099
Drain valve, fully automatic condensate drainage		G1/2	DV-1/2e2	PL 18040
Float controlled drain valve, electronically actuated		G3/4	DV3/4e	PBZ 5049-000

