

# Active and Passive Brakes Series OSP-P



## Contents

Description	Data Sheet No.	Page
Overview	P-1.42.001E	69-70
Standard cylinder with Active brake	P-1.42.002E	71-74
Plain bearing SLIDELINE with Active brake	P-1.40.002E	41-42
Aluminium roller guide PROLINE with Active brake	P-1.40.005E	47-48
Plain bearing SLIDELINE with Passive brake Multibrake	P-1.42.003E	75-78
Aluminium roller guide PROLINE with Passive brake Multibrake	P-1.42.004E	79-81

## Active Brakes and Passive Brakes

### Active Brake

for pneumatic linear drive  
Series OSP-P  
Piston diameters 25 - 80 mm.

See data sheet no. P-1.42.002E



### Versions:

- ACTIVE Brake
- Plain bearing guide with integrated ACTIVE Brake
- Aluminium roller guide with integrated ACTIVE Brake
- Plain bearing guide with PASSIVE Brake
- Aluminium roller guide with PASSIVE Brake

### Slideline with Active Brake

Plain bearing guide SLIDELINE - SL  
with integrated ACTIVE Brake  
Piston diameters 25 - 50 mm.

See data sheet no. P-1.40.002E

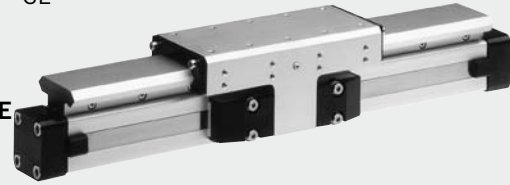

### Proline with Active Brake

Aluminium roller guide  
PROLINE - PL with  
integrated ACTIVE Brake  
Piston diameters 25 - 50 mm.

See data sheet no. P-1.40.005E



### Multibrake with Slideline

MULTI BRAKE – PASSIVE Brake  
with plainbearing guide  
SLIDELINE - SL  
Piston diameter 25 - 80 mm.

See data sheet no. P-1.42.003E

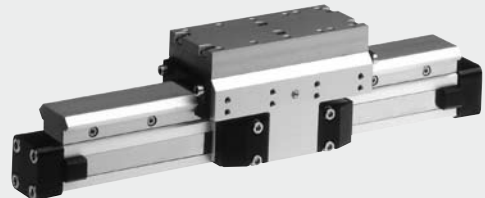

### Multibrake with Proline

MULTI BRAKE – PASSIVE Brake with  
aluminium roller guide  
PROLINE - PL  
Piston diameters 25 - 50 mm.

See data sheet no. P-1.42.004E



P-A1 P616E00HAA00X

The right to introduce technical modifications is reserved

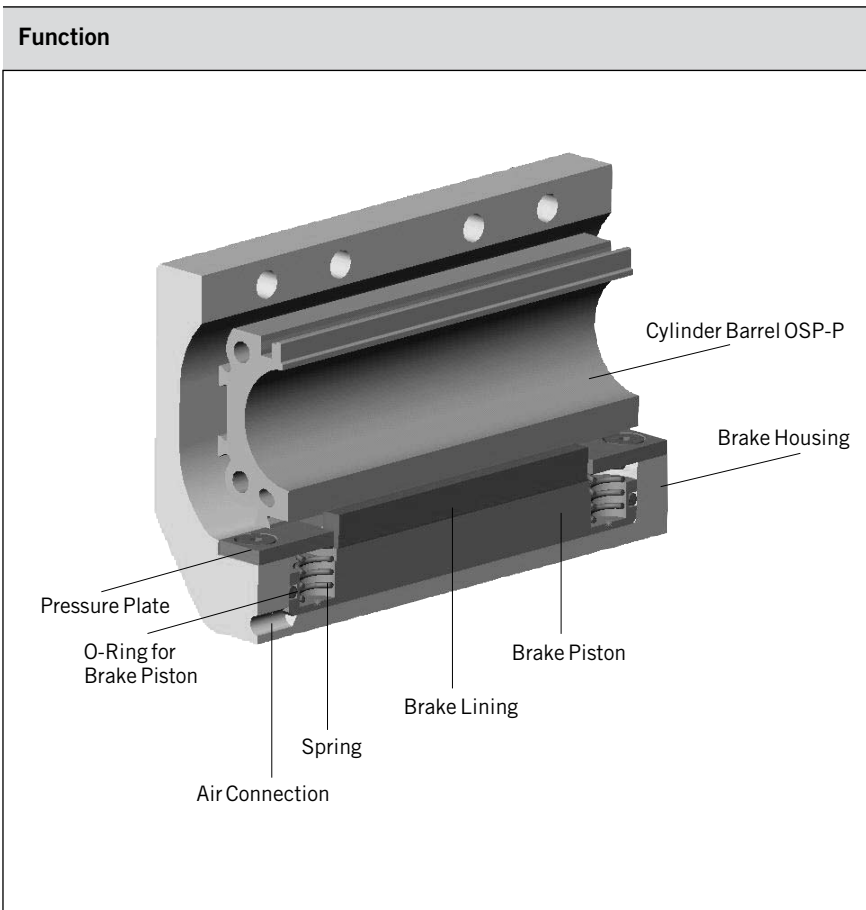

# Active Brake



**Series AB 25 to 80  
for linear drive**  
• **Series OSP-P**

**Features:**

- Actuated by pressurisation
- Released by spring actuation
- Completely stainless version
- Holds position, even under changing load conditions

For further technical data, please refer to the data sheets for linear drives OSP-P (P-1.10.002E).

**Note:**

For combinations Active Brake AB + SFI-plus + Magnetic Switch contact our technical department please.

**Forces and Weights**

Series	For linear drive	Max. braking force [N] <sup>(1)</sup>	Brake pad way [mm]	Mass [kg]			Order No. Active brake
				Linear drive with brake 0 mm stroke	increase per 100mm stroke	brake*	
<b>AB 25</b>	OSP-P25	350	2.5	1.0	0.197	0.35	<b>20806</b>
<b>AB 32</b>	OSP-P32	590	2.5	2.02	0.354	0.58	<b>20807</b>
<b>AB 40</b>	OSP-P40	900	2.5	2.83	0.415	0.88	<b>20808</b>
<b>AB 50</b>	OSP-P50	1400	2.5	5.03	0.566	1.50	<b>20809</b>
<b>AB 63</b>	OSP-P63	2170	3.0	9.45	0.925	3.04	<b>20810</b>
<b>AB 80</b>	OSP-P80	4000	3.0	18.28	1.262	5.82	<b>20811</b>

<sup>(1)</sup> – at 6 bar  
both chambers pressurised with 6 bar  
Braking surface dry  
– oil on the braking surface will reduce the braking force

**\* Please Note:**  
The mass of the brake has to be added to the total moving mass when using the cushioning diagram.

For additional information on loads, forces and moment, please refer to data sheet no. P-1.10.002E



Series OSP-P25 and P32 with Active Brake AB

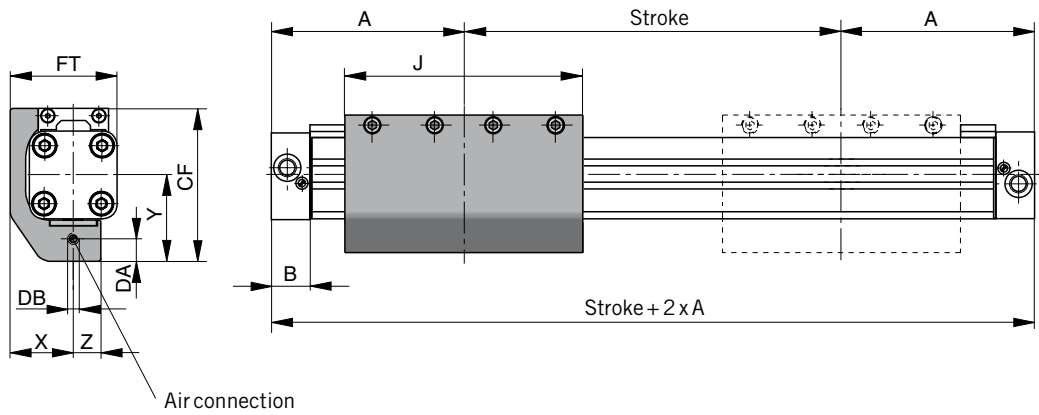

Series OSP-P40, P50, P63, P80 with Active Brake AB

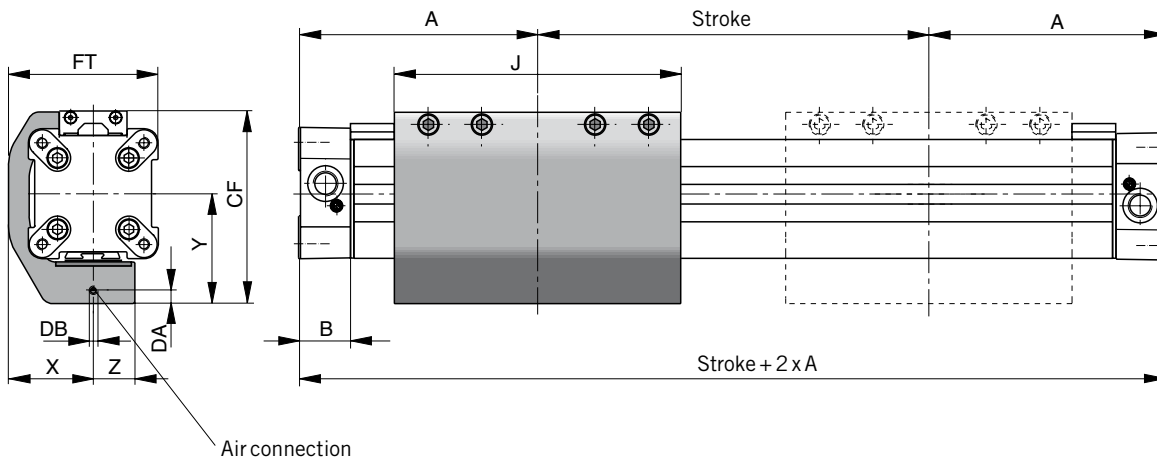

Dimension Table (mm)

Series	A	B	J	X	Y	Z	CF	DA	DB	FT
AB 25	100	22	117	29.5	43	13	74	4	M5	50
AB 32	125	25.5	151.4	36	50	15	88	4	M5	62
AB 40	150	28	151.4	45	58	22	102	7	M5	79.5
AB 50	175	33	200	54	69.5	23	118.5	7.5	M5	97.5
AB 63	215	38	256	67	88	28	151	9	G1/8	120
AB 80	260	47	348	83	105	32	185	10	G1/8	149

**Series OSP – P25 and P32 with Active Brake AB: Type A3**

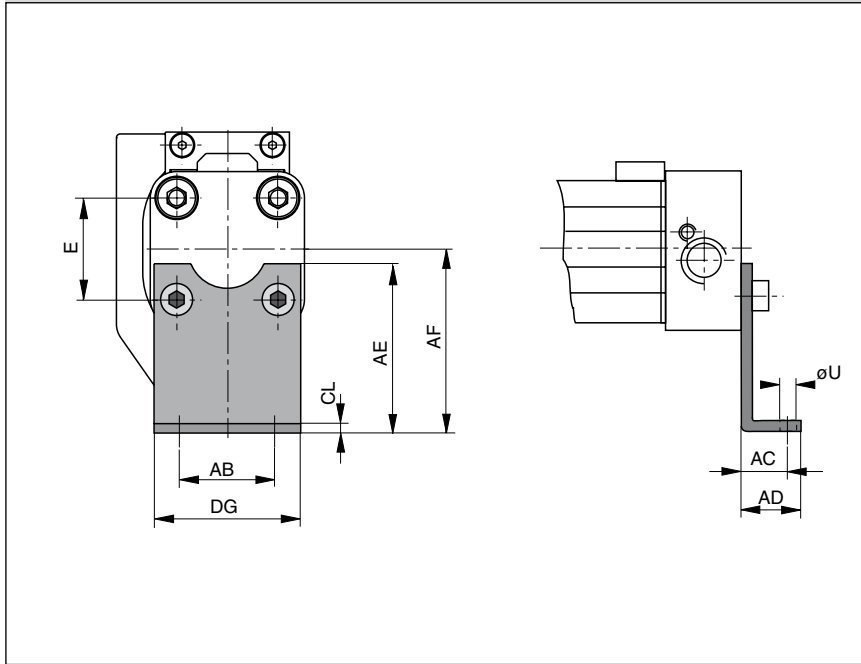

**End Cap Mountings**

On the end-face of each cylinder end cap there are four threaded holes for mounting the cylinder. The hole layout is square, so that the mounting can be fitted to the bottom, top or either side.

Material: Series OSP-P25, P32:  
Galvanised steel

The mountings are supplied in pairs.



**Series OSP – P40 , P50, P63, P80 with Active Brake AB: Type C3**

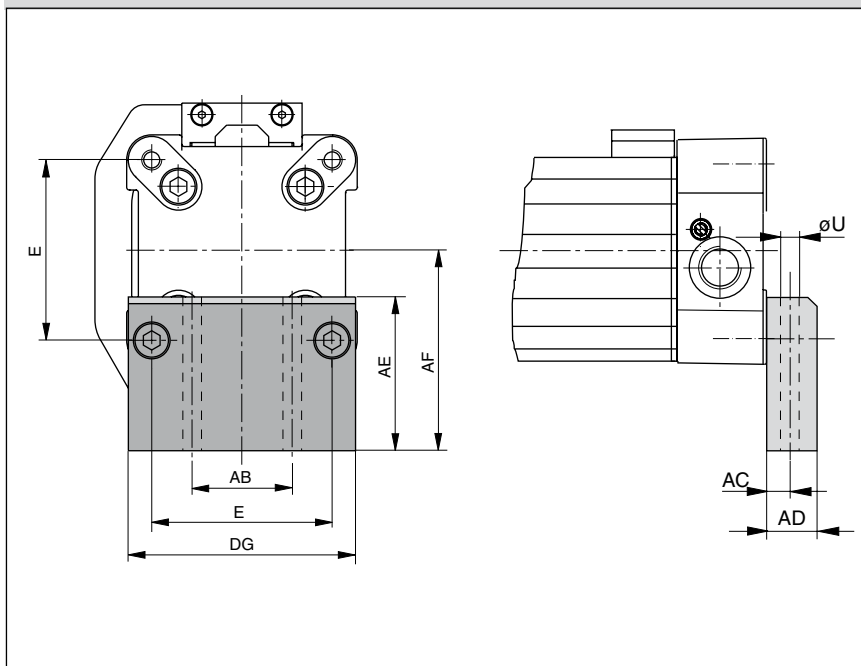

Material: Series OSP-P40,P50,  
P63, P80:  
Anodised aluminium

The mountings are supplied in pairs.

Stainless steel version on request.



**Dimension Table (mm)**

Series	E	øU	AB	AC	AD	AE	AF	CL	DG	Order No. Type A3	Type C3
AB 25	27	5.8	27	16	22	45	49	2.5	39	2060	–
AB 32	36	6.6	36	18	26	42	52	3	50	3060	–
AB 40	54	9	30	12.5	24	46	60	–	68	–	20339
AB 50	70	9	40	12.5	24	54	72	–	86	–	20350
AB 63	78	11	48	15	30	76	93	–	104	–	20821
AB 80	96	14	60	17.5	35	88	110	–	130	–	20822

## Mid Section Support

Mid-section supports are required from a certain stroke length to prevent excessive deflection and vibration of the linear drive.

The diagrams show the maximum permissible unsupported length in relation to loading. Deflection of 0.5 mm max. between supports is permissible.

The mid section supports are attached to the dovetail rails, and can take axial loads.

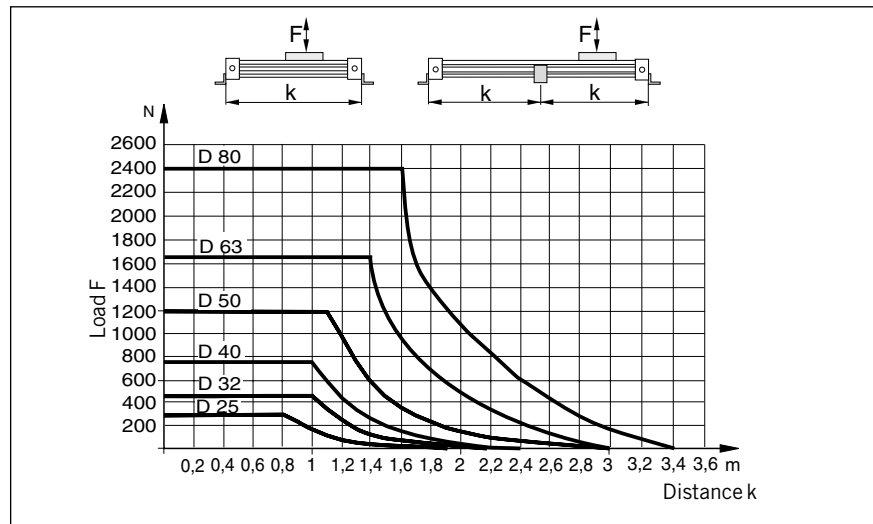

## Mid Section Supports

Note to Type E3:

Mid section supports can only be mounted opposite of the brake housing.

Stainless steel version available on request.



### Series OSP-P25 to P80 with Active Brake AB: Type E3 (Mounting from above / below with through-bolt)

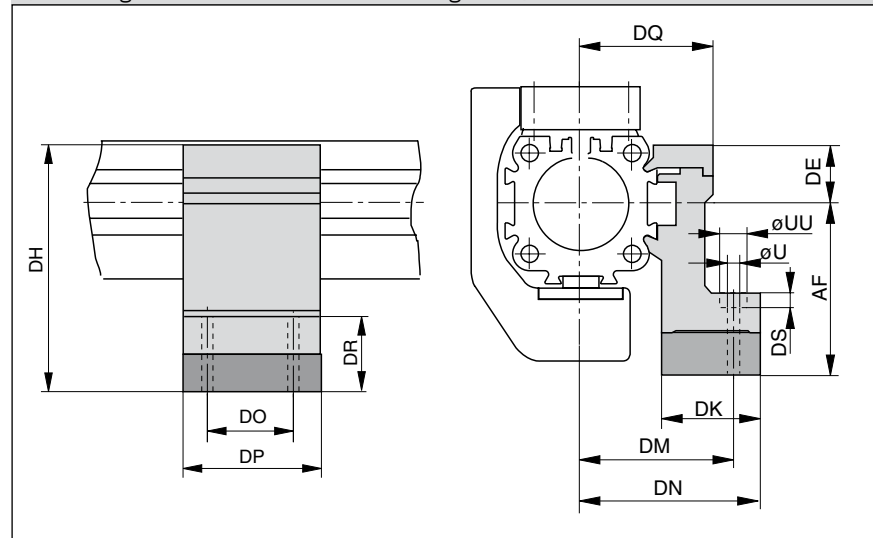

Dimension Table (mm)

Series	U	UU	AF	DE	DH	DK	DM	DN	DO	DP	DQ	DR	DS	Order No. Type E3
AB 25	5.5	10	49	16	65	26	40	47.5	36	50	34.5	35	5.7	20353
AB 32	5.5	10	52	16	68	27	46	54.5	36	50	40.5	32	5.7	20356
AB 40	7	-	60	23	83	34	53	60	45	60	45	32	-	20359
AB 50	7	-	72	23	95	34	59	67	45	60	52	31	-	20362
AB 63	9	-	93	34	127	44	73	83	45	65	63	48	-	20453
AB 80	11	-	110	39.5	149.5	63	97	112	55	80	81	53	-	20819

### Accessories for linear drives with Active Brakes – please order separately

Description	For details information, see data sheet no.
Clevis mounting	P-1.45.002E
Adaptor profile	P-1.45.007E
T-groove profile	P-1.45.008E
Connection profile	P-1.45.009E
Magnetic switch (can <b>only</b> be mounted opposite of the brake housing)	P-1.45.100E, P-1.45.104E
Incremental displacement measuring system SFI-plus	P-1.50.002E

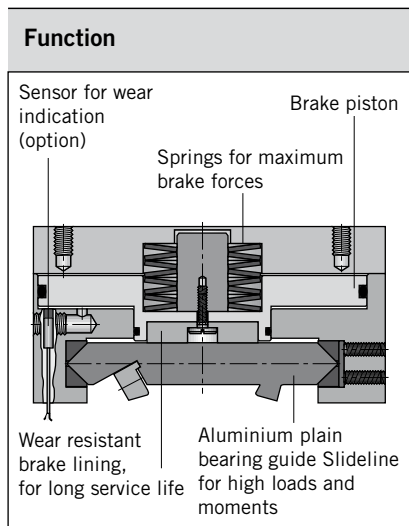
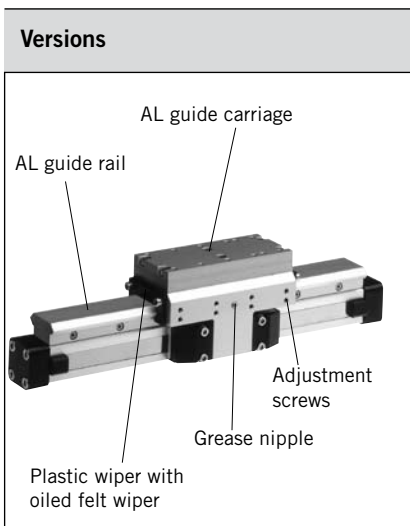

# Multi-Brake Passive Brake with plain bearing guide Slideline SL



Series MB-SL 25 to 80  
for Linear-drive  
• Series OSP-P

### Function:

The Multi-Brake is a passive device. When the air pressure is removed the brake is actuated and movement of the cylinder is blocked. The brake is released by pressurisation.

The high friction, wear resistant brake linings allow the Multi-Brake to be used as a dynamic brake to stop cylinder movement in the shortest possible time. The powerful springs also allow the Multi-Brake to be used effectively in positioning applications.

### Features:

- Brake operated by spring actuation
- Brake release by pressurisation
- Optional sensor to indicate brake lining wear
- Anodised aluminium rail, with prism shaped slide elements
- Adjustable plastic slide elements
- Composite sealing system with plastic and felt wiper elements to remove dirt and lubricate the slideway
- Replenishable guide lubrication by integrated grease nipples
- Blocking function in case of pressure loss
- Intermediate stops possible

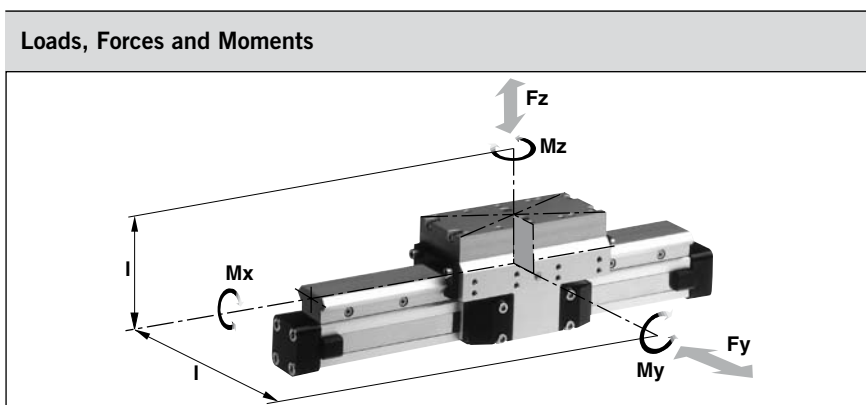

### Technical Data:

The table shows the maximum values for light, shock-free operation, which must not be exceeded even in dynamic operation.

Load and moment data are based on speeds  $v < 0.2$  m/s.

Operating pressure 4.5 - 8 bar  
A pressure of 4.5 bar is required to release the brake.

For further technical information, please refer to the data sheets for linear drives OSP-P (P-1.10.002E)

<sup>1)</sup> Braking surface dry – oil on the braking surface will reduce the braking force

\* **Please note:**  
in the cushioning diagram, the mass of the guide carriage has to be added to the total moving mass.

Series	For linear drive	Max. moments [Nm]			Max. loads [N] Ly, Lz	Max. brake force [N] <sup>1)</sup>	Mass of linear drive with guide [kg]		Mass* guide carriage [kg]	Order No. –MB-SL	
		Mx	My	Mz			with 0 mm stroke	increase per 100 mm stroke		without sensor	with sensor for wear indication
MB-SL 25	OSP-P25	14	34	34	675	470	2.04	0.39	1.10	20796	on request
MB-SL 32	OSP-P32	29	60	60	925	790	3.82	0.65	1.79	20797	on request
MB-SL 40	OSP-P40	50	110	110	1500	1200	5.16	0.78	2.34	20798	on request
MB-SL 50	OSP-P50	77	180	180	2000	1870	8.29	0.97	3.63	20799	on request
MB-SL 63	OSP-P63	120	260	260	2500	2900	13.31	1.47	4.97	20800	on request
MB-SL 80	OSP-P80	120	260	260	2500	2900	17.36	1.81	4.97	20846	on request

For linear drives see P-1.10.002E  
For mountings see P-1.45.005E

Series OSP-P with Passive Brake MB-SL

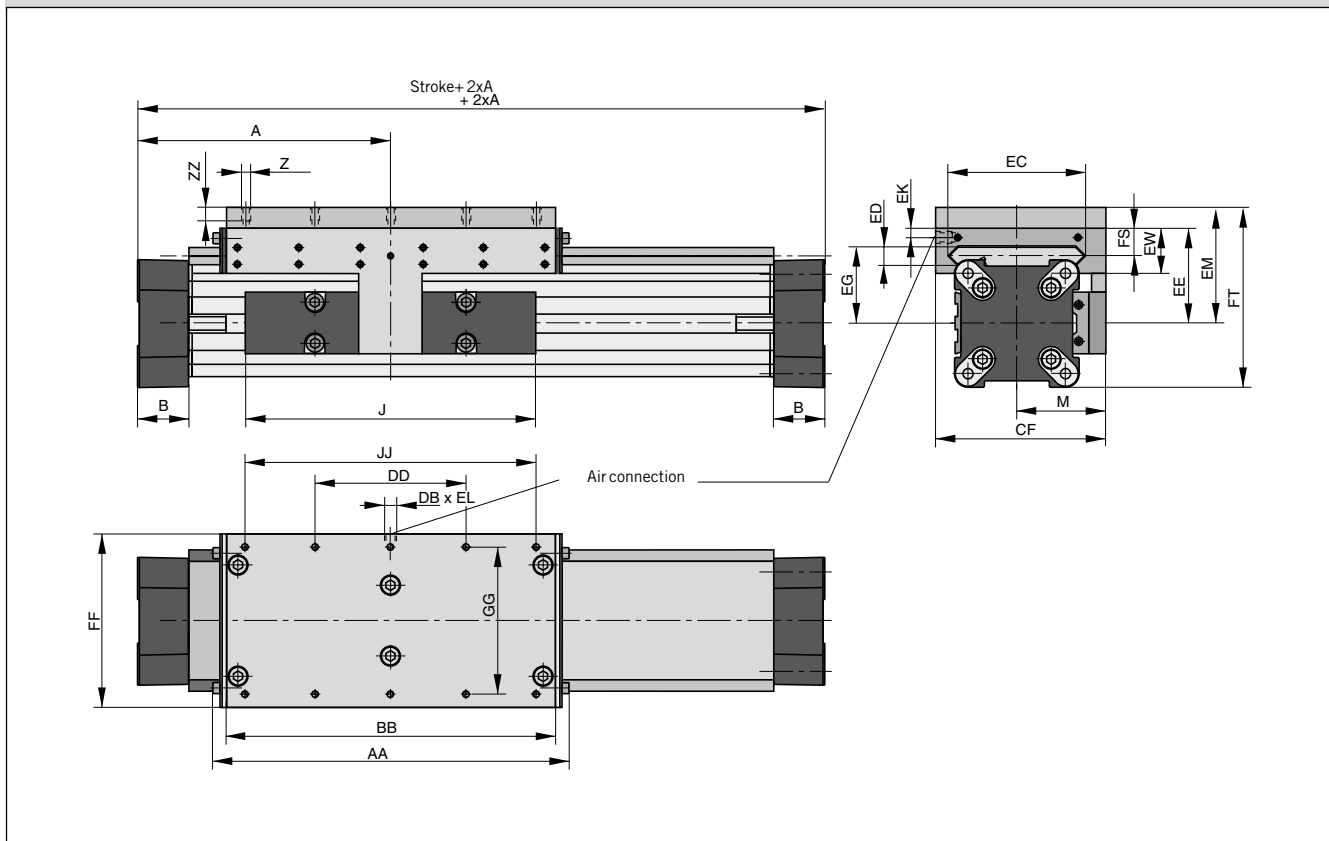

Dimension Table (mm)

Series	A	B	J	M	Z	AA	BB	DB	DD	CF	EC	ED	EE	EG	EK	EL	EM	EW	FF	FT	FS	GG	JJ	ZZ
MB-SL25	100	22	117	40,5	M6	162	142	M5	60	72.5	47	12	53	39	9	5	73	30	64	93.5	20	50	120	12
MB-SL32	125	25.5	152	49	M6	205	185	G1/8	80	91	67	14	62	48	7	10	82	33	84	108	21	64	160	12
MB-SL40	150	28	152	55	M6	240	220	G1/8	100	102	77	14	64	50	6.5	10	84	34	94	118.5	21.5	78	200	12
MB-SL50	175	33	200	62	M6	284	264	G1/8	120	117	94	14	75	56	10	12	95	39	110	138.5	26	90	240	12
MB-SL63	215	38	256	79	M8	312	292	G1/8	130	152	116	18	86	66	11	12	106	46	152	159	29	120	260	13
MB-SL80	260	47	348	96	M8	312	292	G1/8	130	169	116	18	99	79	11	12	119	46	152	185	29	120	260	13

## Loading

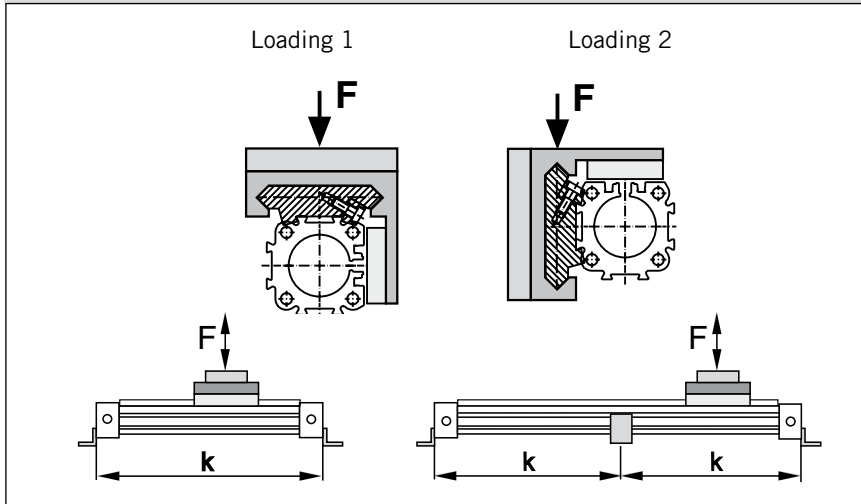

## Mid Section Support

(for versions see P-1.45.005E)

Mid section supports are required from a certain stroke length to prevent excessive deflection and vibration of the linear drive.

The diagrams show the maximum permissible unsupported length in relation to loading. A distinction must be drawn between loading 1 and loading 2. Deflection of 0.5 mm max. between supports is permissible.

### Note:

For speeds  $v > 0.5$  m/s the distance between supports should not exceed 1 m.

## Permissible Unsupported Length MB-SL25, MB-SL32

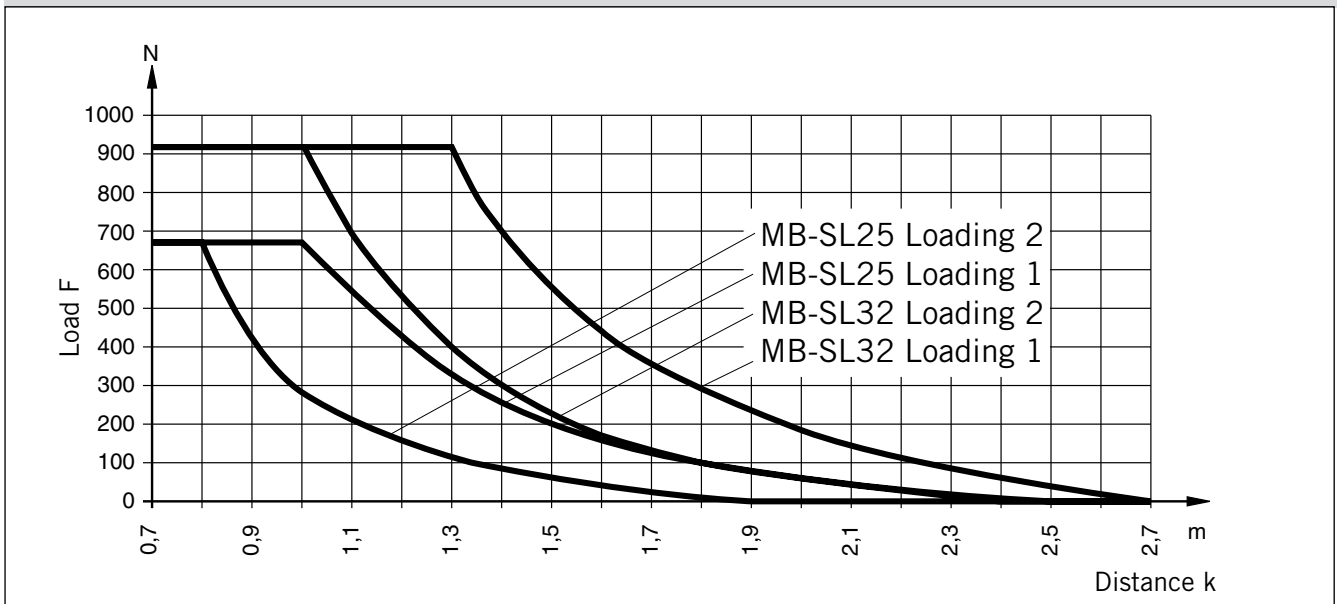

## Permissible Unsupported Length MB-SL40, MB-SL50, MB-SL63 and MB-SL80

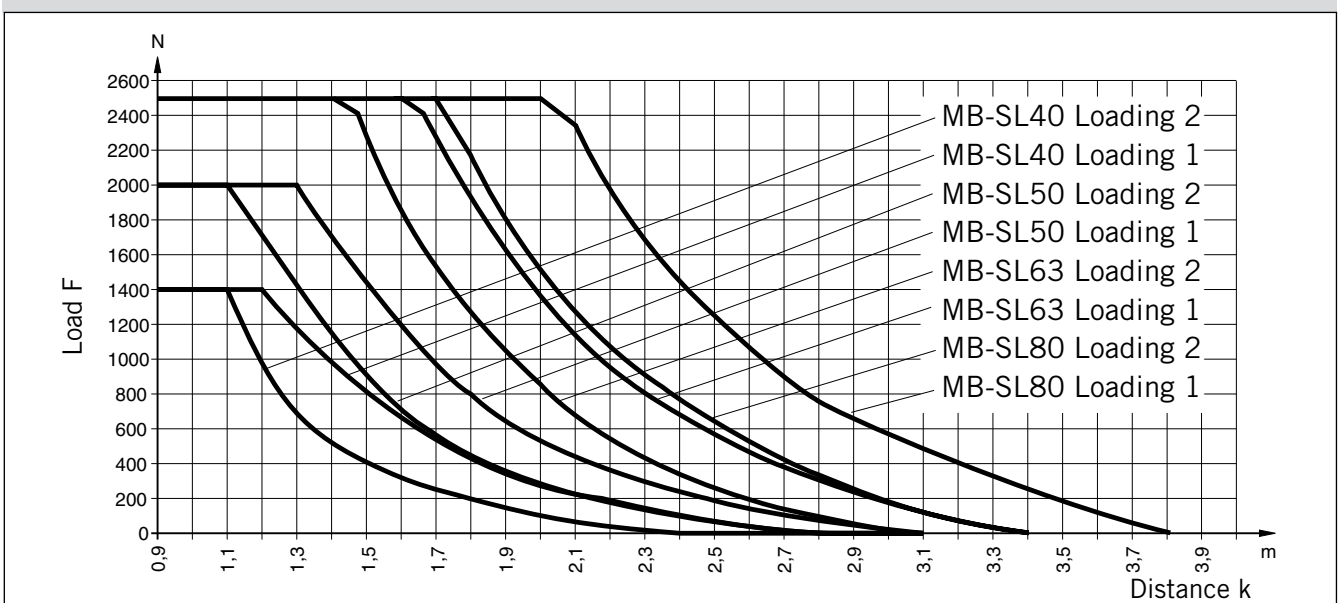

## Application Example - Vertical Application

Control of a cylinder with 3/2 way valves. Basic position – **exhausted**

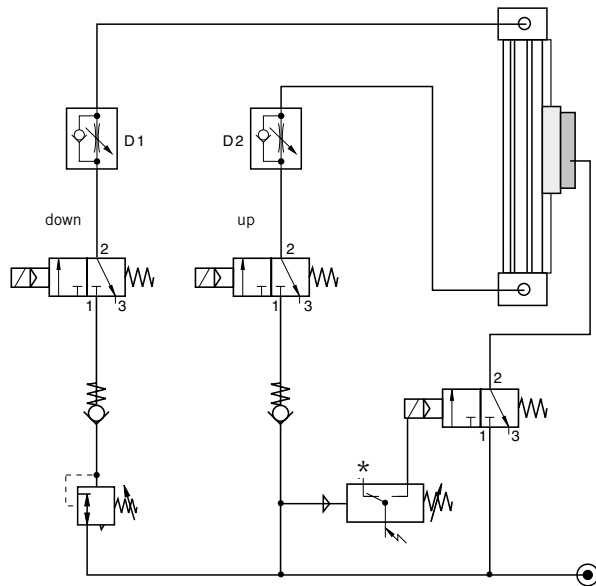

Control of a cylinder with 3/2 way valves. Basic position – **pressurised**

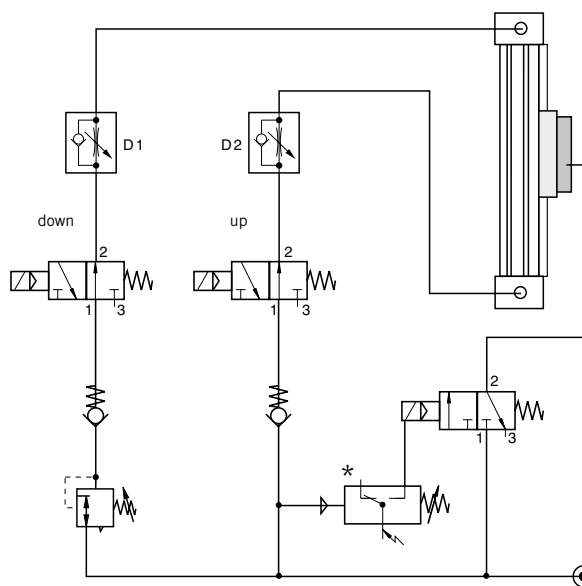

### Control Examples

Under normal operating circumstances the pressure switch is closed and the air flows through the 3/2 way solenoid valves from port 1 to 2, thus lifting the brake from the rail (operating condition).

The brake is pressurised by means of a 3/2 way valve in combination with a pressure switch. When there is a pressure loss, the brake is actuated by the pressure switch.

When the air pressure is restored to both cylinder chambers, the brake is lifted and the linear drive can be moved again.

The speed regulating valves D1 and D2 control the speed of the linear drive, and have no influence on the brake. The two non-return valves give the system a higher stability.

The pressure regulating valve is used to compensate for the downward force in this vertical application.



**Please note:**  
**Before the brake is lifted, make sure that both air chambers of the linear drive are pressurised.**  
**Small diameter tubing, fittings and valves with a nominal diameter, and tubing that is too long all change the reaction time of the brake!**

**\* Tip:**  
 The pressure switch actuates the brake when the pressure drops below the set value.

For accessories, such as tubing and fittings, please refer to our separate catalogue.

### Required Components

Way Valves	
Port size	see catalogue
M5, G1/8	Valves
G1/4, G1/2	A4P026E
Pressure Regulating Valves	
G1/8 - G3/8	see catalogue
	Air Preparation
	A4P006E
Pneumatic Accessories	
P/E-Switch	see catalogue
Non-Return Valves	Pneumatic Accessories
G1/8 - G3/8	A4P021E
Screw-in Speed Regulating Valves	
M5 - G1/4	

P-A1 P616E00JY00X

The right to introduce technical modifications is reserved

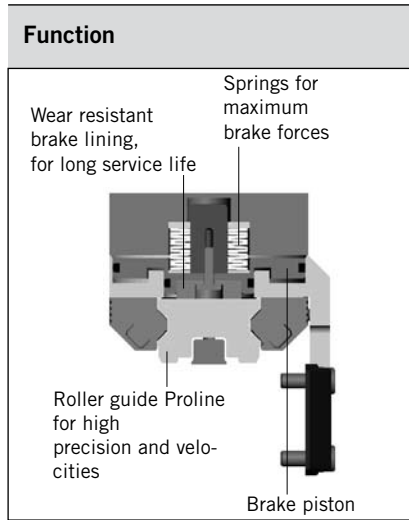
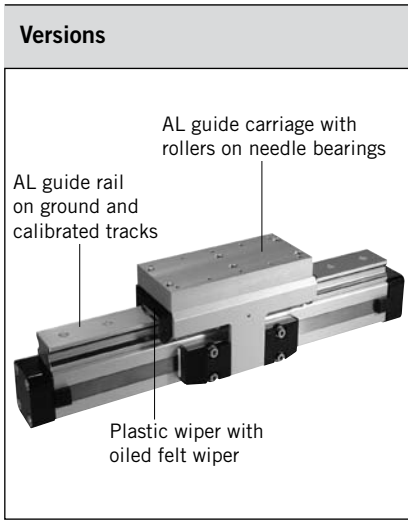

# Multi-Brake Passive Brake with Aluminium Roller Guide Proline PL



Series MB-PL 25 to 50  
for Linear-drive  
• Series OSP-P

### Function:

The Multi-Brake is a passive device. When the air pressure is removed the brake is actuated and movement of the cylinder is blocked. The brake is released by pressurisation.

The high friction, wear resistant brake linings allow the Multi-Brake to be used as a dynamic brake to stop cylinder movement in the shortest possible time. The powerful springs also allow the Multi-Brake to be used effectively in positioning applications.

### Features:

- Brake operated by spring actuation
- Brake release by pressurisation
- Optional sensor to indicate brake lining wear
- Composite sealing system with plastic and felt wiper elements to remove dirt and lubricate the slideway
- Blocking function in case of pressure loss
- Intermediate stops possible

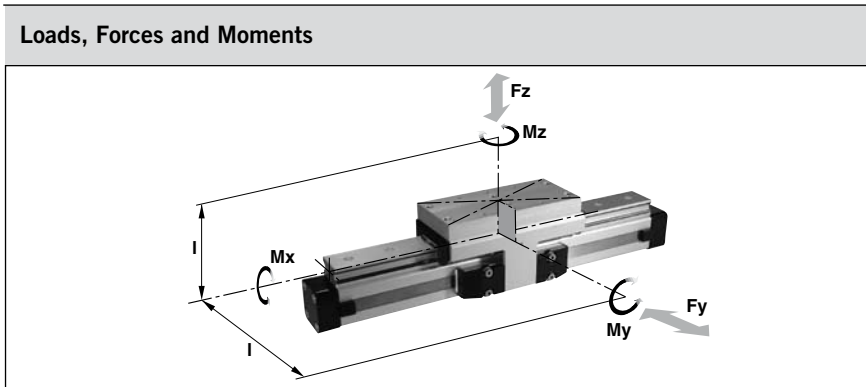

### Technical Data

The table shows the maximal permissible loads. If multiple moments and forces act upon the cylinder simultaneously, the following equation applies:

$$\frac{M_x}{M_{x_{max}}} + \frac{M_y}{M_{y_{max}}} + \frac{M_z}{M_{z_{max}}} + \frac{F_y}{F_{y_{max}}} + \frac{F_z}{F_{z_{max}}} \leq 1$$

The sum of the loads should not exceed >1. With a load factor of less than 1, service life is 8000 km

The table shows the maximum permissible values for light, shock-free operation, which must not be exceeded even under dynamic conditions.

Operating Pressure 4.5 - 8 bar. A pressure of min. 4.5 bar release the brake.

<sup>1)</sup> Braking surface dry – oil on the braking surface will reduce the braking force

#### \* Please note:

In the cushioning diagram, the mass of the guide carriage has to be added to the total moving mass.

Series	For linear drive	Max. moments [Nm]			Max. loads [N] F <sub>y</sub> , F <sub>z</sub>	Max. brake force [N] <sup>1)</sup>	Mass of linear drive with guide [kg]		Mass* guide carriage [kg]	Order No. – MB-PL	
		M <sub>x</sub>	M <sub>y</sub>	M <sub>z</sub>			with 0 mm stroke	increase per 100 mm stroke		without sensor	with sensor for wear indication
MB-PL25	OSP-P25	16	39	39	857	315	2.14	0.40	1.24	20864	on request
MB-PL32	OSP-P32	29	73	73	1171	490	4.08	0.62	2.02	20865	on request
MB-PL40	OSP-P40	57	158	158	2074	715	5.46	0.70	2.82	20866	on request
MB-PL50	OSP-P50	111	249	249	3111	1100	8.60	0.95	4.07	20867	on request

For linear drives see P-1.10.002E  
For mountings see P-1.45.005E

## Series OSP-P with Passive Brake MB-PL

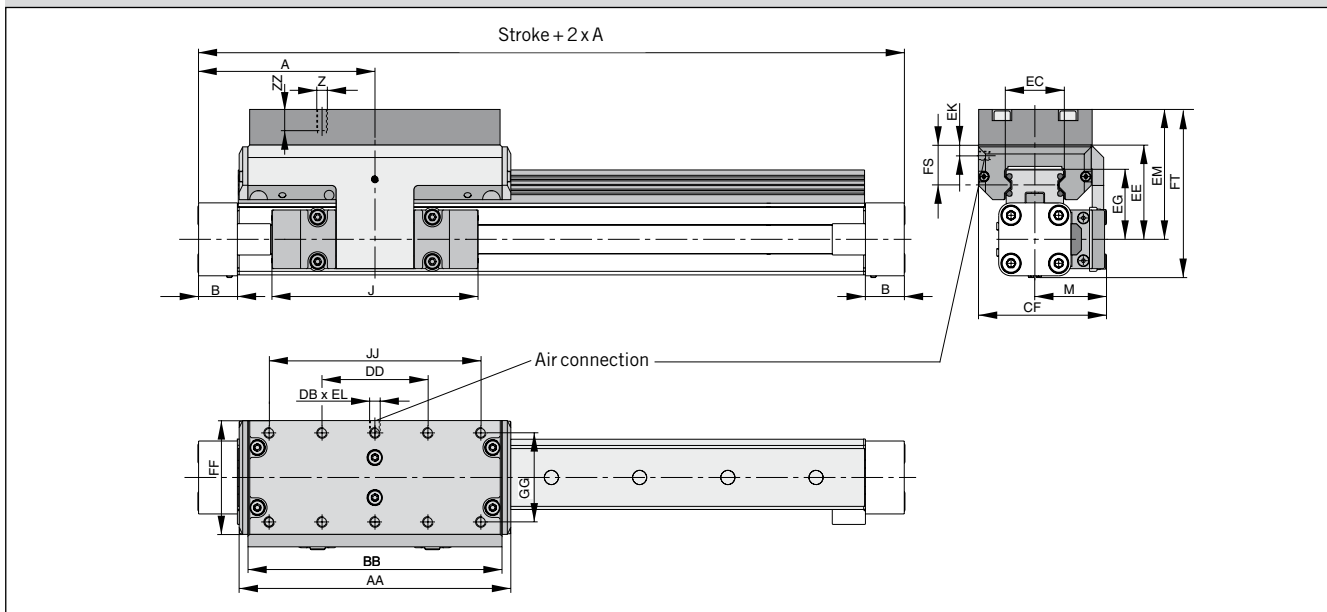

Dimension Table (mm) Series OSP-P MB-PL25, MB-PL32, MB-PL40, MB-PL50

Series	A	B	J	M	Z	AA	BB	DB	DD	CF	EC	EE	EG	EK	EL	EM	FF	FS	FT	GG	JJ	ZZ
MB-PL25	100	22	117	40.5	M6	154	144	M5	60	72.5	32.5	53	39	9	5	73	64	23	93.5	50	120	12
MB-PL32	125	25.5	152	49	M6	197	187	G1/8	80	91	42	62	48	7	10	82	84	25	108	64	160	12
MB-PL40	150	28	152	55	M6	232	222	G1/8	100	102	47	64	50.5	6.5	10	84	94	23.5	118.5	78	200	12
MB-PL50	175	33	200	62	M6	276	266	G1/8	120	117	63	75	57	10	12	95	110	29	138.5	90	240	16

## Mid Section Support

(for versions see P-1.45.005E)

Mid section supports are required from a certain stroke length to prevent excessive deflection and vibration of the linear drive. The diagrams show the maximum permissible unsupported length in relation to loading. A distinction must be drawn between loading 1 and loading 2. Deflection of 0.5 mm max. between supports is permissible.

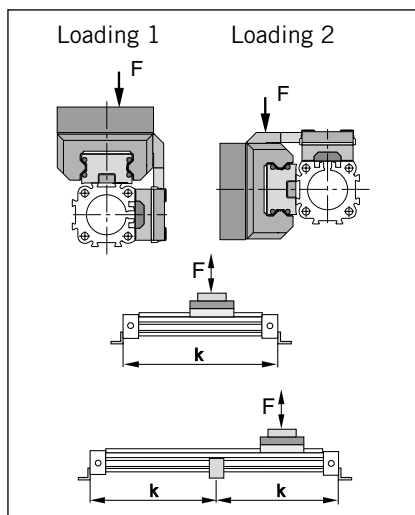

### Note:

For speeds  $v > 0.5$  m/s the distance between supports should not exceed 1 m.

Permissible Unsupported Length OSP-P MB-PL25, MB-PL32, MB-PL40, MB-PL50

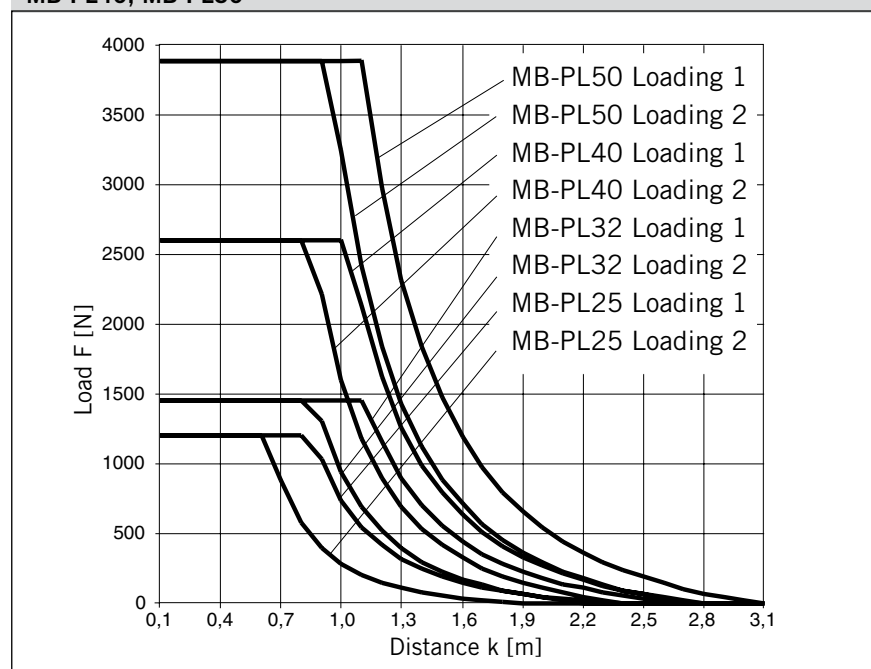

## Application Example - Vertical Application

Control of a cylinder with 3/2 way valves. Basic position – **exhausted**

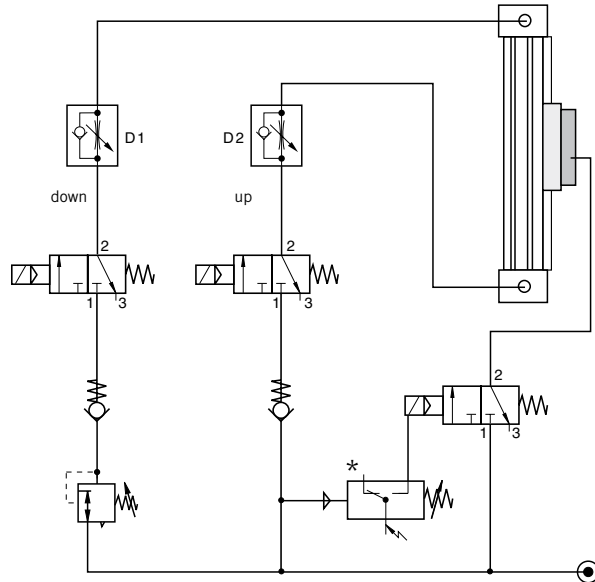

Control of a cylinder with 3/2 way valves. Basic position – **pressurised**

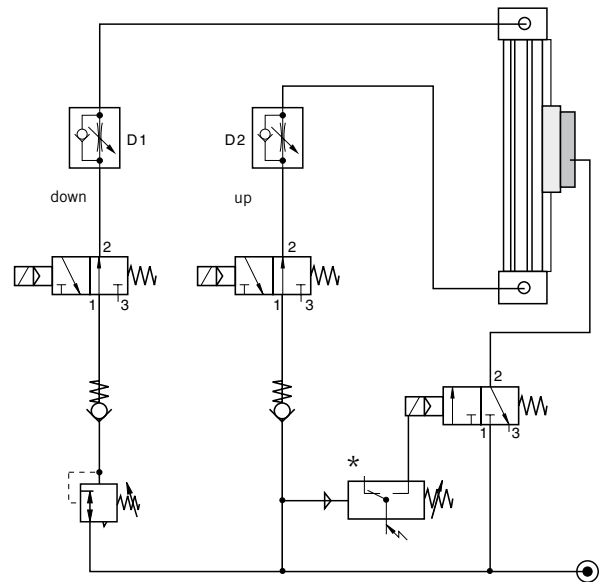

### Control Examples

Under normal operating circumstances the pressure switch is closed and the air flows through the 3/2 way solenoid valves from port 1 to 2, thus lifting the brake from the rail (operating condition).

The brake is pressurised by means of a 3/2 way valve in combination with a pressure switch. When there is a pressure loss, the brake is actuated by the pressure switch.

When the air pressure is restored to both cylinder chambers, the brake is lifted and the linear drive can be moved again.

The speed regulating valves D1 and D2 control the speed of the linear drive, and have no influence on the brake. The two non-return valves give the system a higher stability. The pressure regulating valve is used to compensate for the downward force in this vertical application.



**Please note:**  
**Before the brake is lifted, make sure that both air chambers of the linear drive are pressurised.**  
**Small diameter tubing, fittings and valves with a nominal diameter, and tubing that is too long all change the reaction time of the brake!**

**\* Tip:**  
 The pressure switch actuates the brake when the pressure drops below the set value.

For accessories, such as tubing and fittings, please refer to our separate catalogue.

### Required Components

Way Valves	
Port size	see catalogue
M5, G1/8	Valves
G1/4, G1/2	A4P026E
Pressure Regulating Valves	
G1/8 - G3/8	see catalogue
	Air Preparation
	A4P006E
Pneumatic Accessories	
P/E-Switch	see catalogue
Non-Return Valves	Pneumatic Accessories
G1/8 - G3/8	A4P021E
Screw-in Speed Regulating Valves	
M5 - G1/4	

