



# ORIGA Stop Cylinders

ORIGA – simply the first

aerospace  
climate control  
electromechanical  
filtration  
fluid & gas handling  
hydraulics  
**pneumatics**  
process control  
sealing & shielding



ENGINEERING YOUR SUCCESS.

# Pneumatic Stop Cylinders

**Pneumatic stop cylinders with hydraulic industrial shock absorbers for soft, rebound-free stopping of a conveyed load.**

## Pneumatic Stop Cylinders

- Soft, rebound-free stopping of a conveyed load.
- Flexible: for vertical or horizontal installation
- Types with shock absorber/roller lever combination, lone roller or roller with a piston rod that ensures direct stoppage
- Shock absorbers are easy to replace, even when fitted
- Rotating stop head for adjustment in line with the direction of travel of the conveyed load
- Rocker can be deactivated for alternate travel function
- Single and double acting cylinder variants
- Operating pressure up to 10 bar
- Different shock absorbers for conveyed load weights of up to 1700 kg and speeds of up to 45 m/min
- Optional: position switch for piston rod and proximity switch for rocker

### **Rocker locking**

*After the conveyed load is stopped, the rocker is lowered and unlocked by applying compressed air. After the conveyed load has been moved, the return spring brings the rocker into its upper end position so that it is back in its start position for the next stopping procedure.*

### **Integrated shock absorbers**

*The shock absorbers, aligned to the weight and speed of the load, ensure gentle and precise stopping of the conveyed load*

### **Guide rod**

*Thanks to the easy-to-replace guide rod, the rocker can be quickly rotated so that the conveyor can move in a different direction.*

### **Diecast Aluminum**

*The design of the robust, lightweight diecast aluminum and its compact size enables it to be installed in many different conveyor systems.*

### **Unrestricted conveyor movement**

*The rocker is held in the OFF position (deactivated) by simply clipping a spring steel sheet onto it. The conveyed load can pass through the stop cylinder unobstructed while the rocker is in this position.*



## Stop Cylinder — Vertical Version

### STVSR series



#### Integrated shock absorber for heavy conveyed loads

The built-in shock absorber stops the conveyed load in a gentle and precise manner without disturbing the load. Various shock absorbers are available depending on the weight of the conveyed load and the desired transport speed.

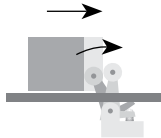

### STVDR series



#### Roller for lower conveyed load weights

The piston rod with upward facing roller is lowered by applying compressed air once the conveyed load is on the ground. Afterwards, it is brought back into the upper end position by a return spring.

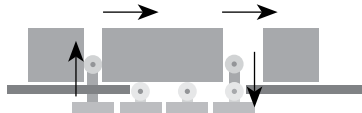

### STVD series



#### Direct stopping piston rod for heavy conveyed loads

Reliably stops heavy conveyed loads at low transport speeds. Can also be used as a locking cylinder due to its solid piston rod.

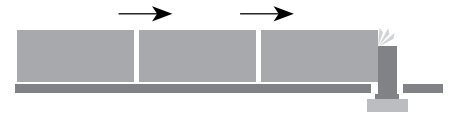

## Stop Cylinder — Horizontal Version

### STHSR series

#### Horizontal stop cylinder with shock absorber

Reliably stops heavy conveyed loads at high transport speeds. Well-suited for buffer areas.

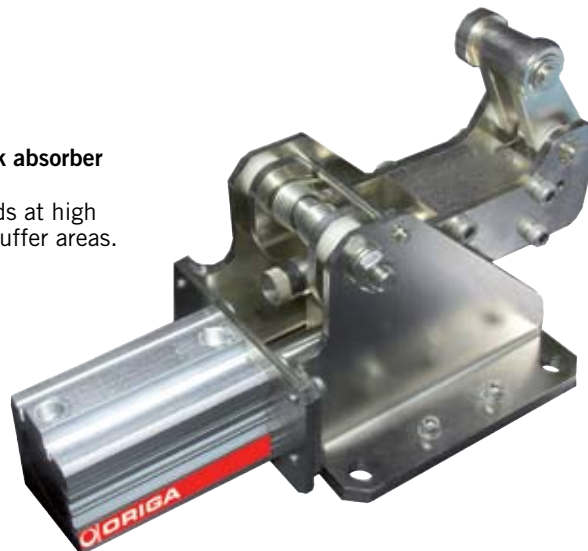

# Pneumatic Stop Cylinders

with hydraulic industrial shock absorbers

## Overview

### Vertical versions

Description	Image	Cylinder Ø (mm)	Stroke (mm)	Type
Vertical stop cylinder with shock absorber and roller lever		50	30	STVSR-50-30-.-...
		80	40	STVSR-80-40-...
Vertical stop cylinder with roller		50	30	STVDR-50-30-...
Vertical stop cylinder with direct stopping piston rod		50	30	STVD-50-30-...

### Horizontal versions

Horizontal stop cylinder with shock absorber and roller lever		50	50	STHSR-50-50-...
---	---	----	----	-----------------

### Wiring diagrams

#### Single acting

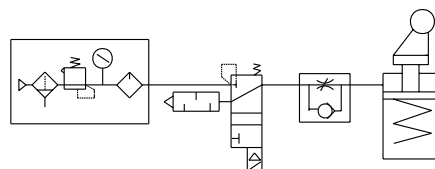

#### Double acting

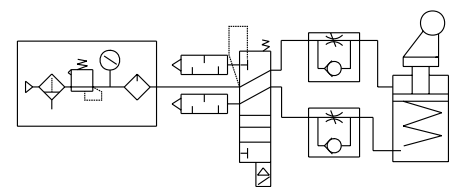

## Specifications

Specification	Symbol	Unit	Comments
Medium			Filtered and unoiled compressed air – if oiled, then continuous
Operating pressure range	$p_{n \text{ min/max}}$	bar	2–10
Test pressure		bar	15 bar
Ambient temperature range	$t_{\text{min}}$ $t_{\text{max}}$	°C °C	0 +65 Note: If intending use below freezing point (0°C), you must consult us for advice.
Lubrication			Unoiled
Cushioning			Cushioning mat made from oil-resistant rubber
Magnetic switch and holder			ORIGA
Stop cylinder weight (mass)			
– Type STVSR-50-30		kg	1800
– Type STVSR-80-40		kg	6820
– Type STVDR-50-30		kg	1800
– Type STVD-50-30		kg	1800
– Type STHSR-50-50		kg	8750

## Pneumatic Stop Cylinders

*with hydraulic industrial shock absorbers\**

*Vertical version*

*STVSR series\*  
STVDR series  
STVD series*

*∅ 50, 80 mm*

*Horizontal version*

*STHSR series\*  
∅ 50 mm*

*Specifications*



See pages 6–13 for vertical versions, see pages 14–15 for horizontal versions

Dimensions in mm

# Pneumatic Stop Cylinders

with hydraulic industrial shock absorbers

Vertical version

STVSR series

Ø 50 mm

Dimensions

## Stop cylinder dimensions Ø 50 — Type STVSR-50-30

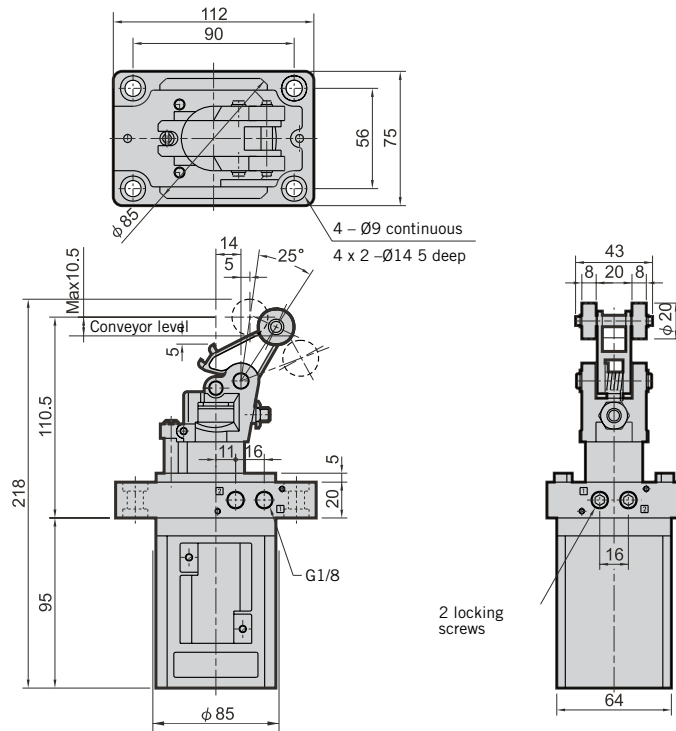

## Option - Rocker locking

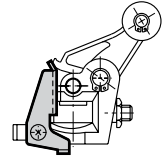
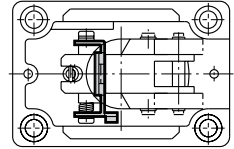

## - Free travel of conveyed load

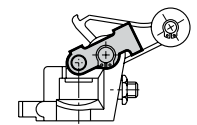
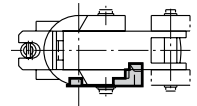

## Loads

## Moving mass subject to speed — Type STVSR-50-30

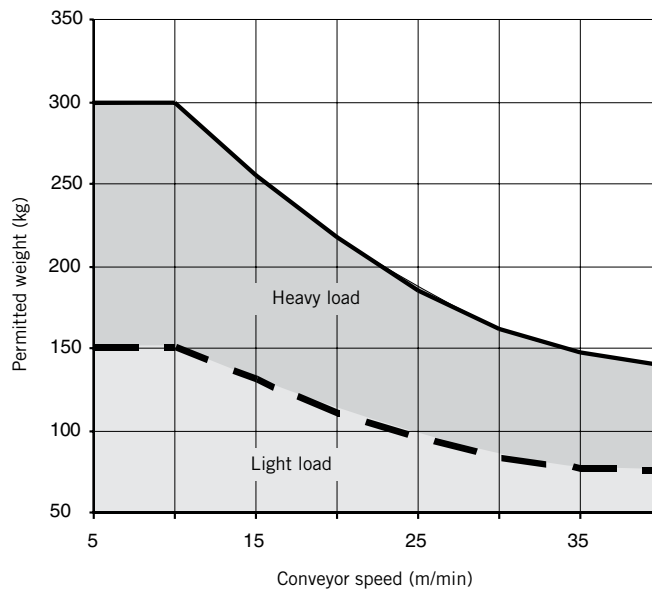

See page 5 for Specifications

Dimensions in mm

**Axial load subject to operating pressure — Type STVSR-50-30**

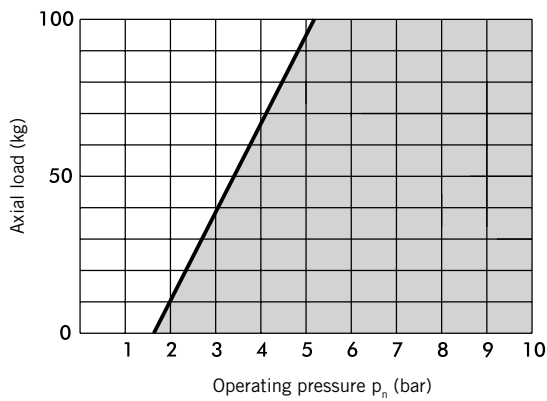

# Pneumatic Stop Cylinders

*with hydraulic industrial shock absorbers*

*Vertical version*

*STVSR series*

*Ø 50 mm*

*Loads*

**Product key**

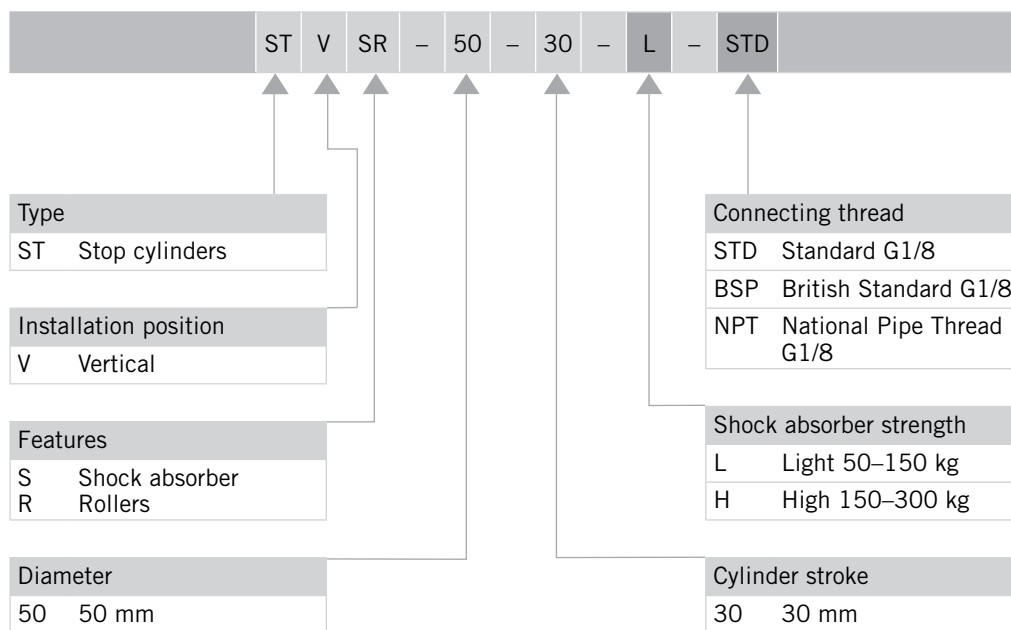

*Order details*



See page 5 for Specifications

Dimensions in mm

# Pneumatic Stop Cylinders

with hydraulic industrial shock absorbers

Vertical version

STVSR series

Ø 80 mm

Dimensions

Stop cylinder dimensions Ø 80 – Type STVSR-80-40

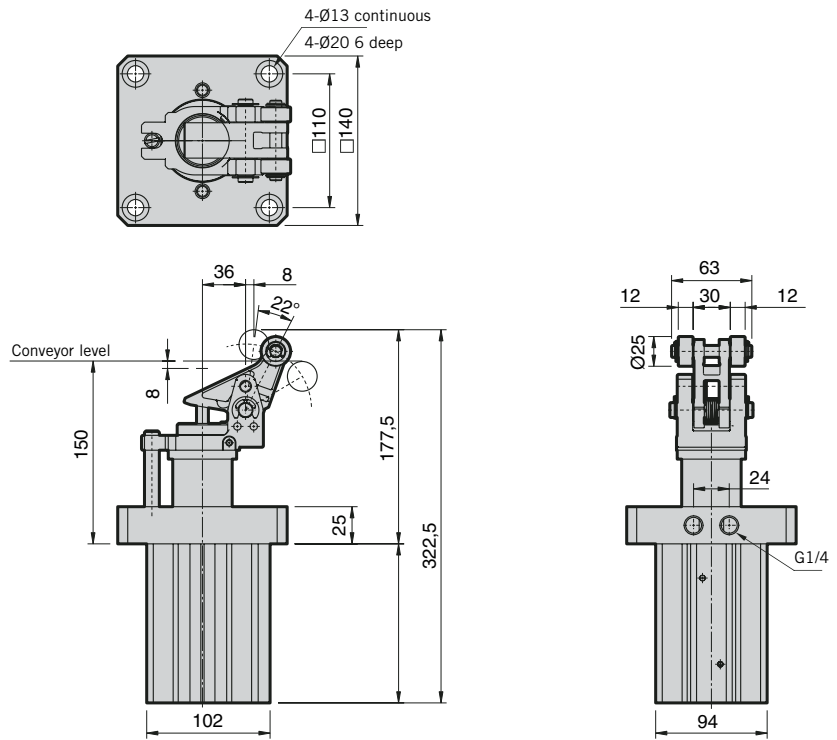

Loads

Moving mass subject to speed — Type STVSR-80-40

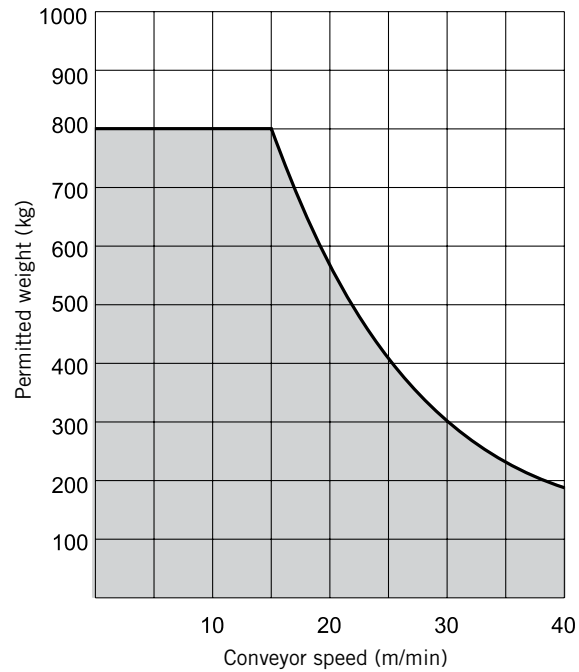

See page 5 for Specifications

Dimensions in mm

**Axial load subject to operating pressure — Type STVSR-80-40**

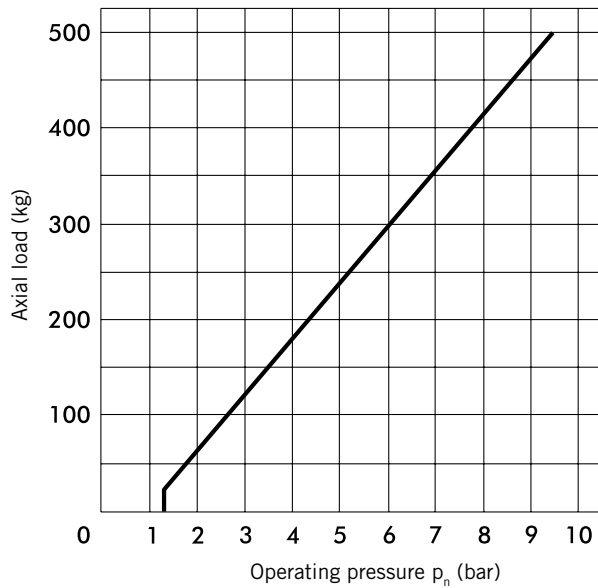

# Pneumatic Stop Cylinders

*with hydraulic industrial shock absorbers*

*Vertical version*

*STVSR series*

*Ø 80 mm*

*Loads*

**Product key**

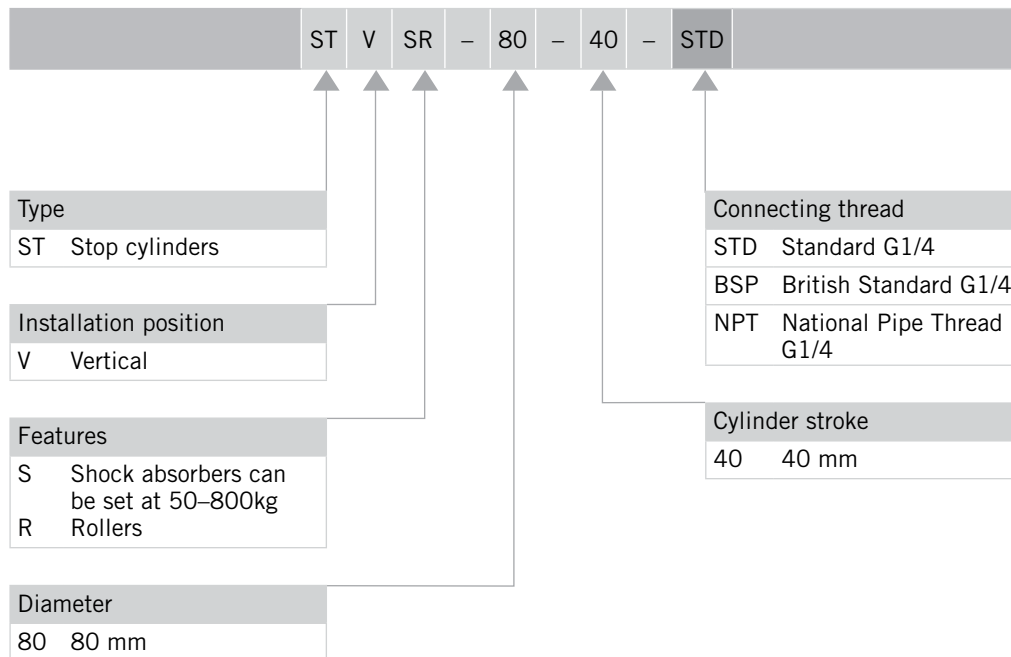

*Order details*



See page 5 for Specifications

Dimensions in mm

# Pneumatic Stop Cylinders

Vertical version

STVDR series

Ø 50 mm

Dimensions

Stop cylinder dimensions Ø 50 — Type STVDR-50-30

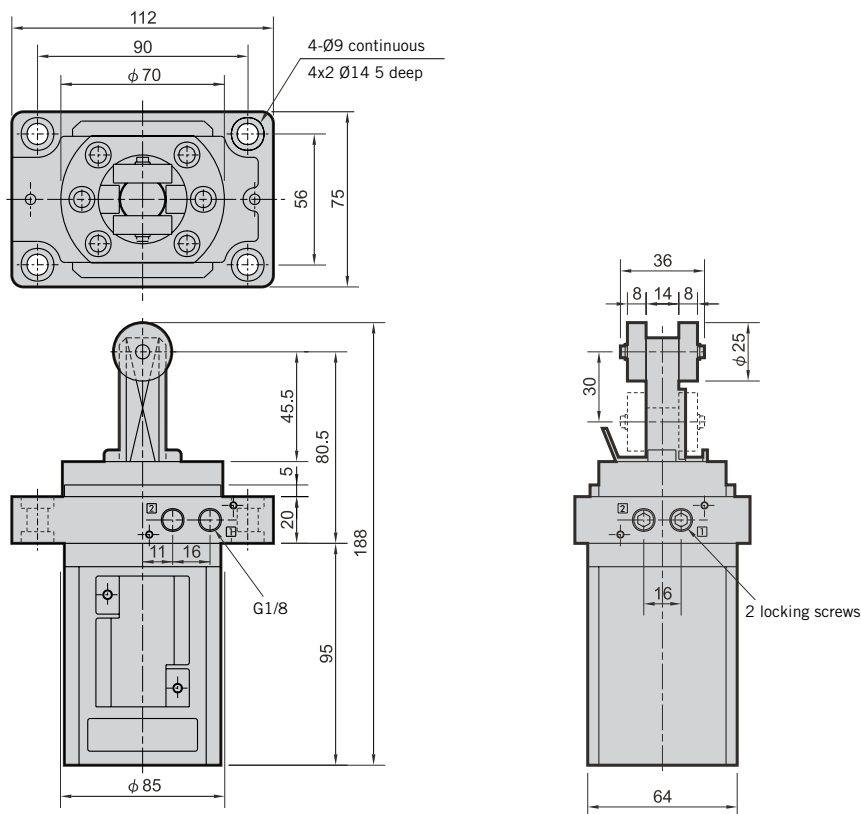

Loads

Moving mass subject to speed — Type STVDR-50-30

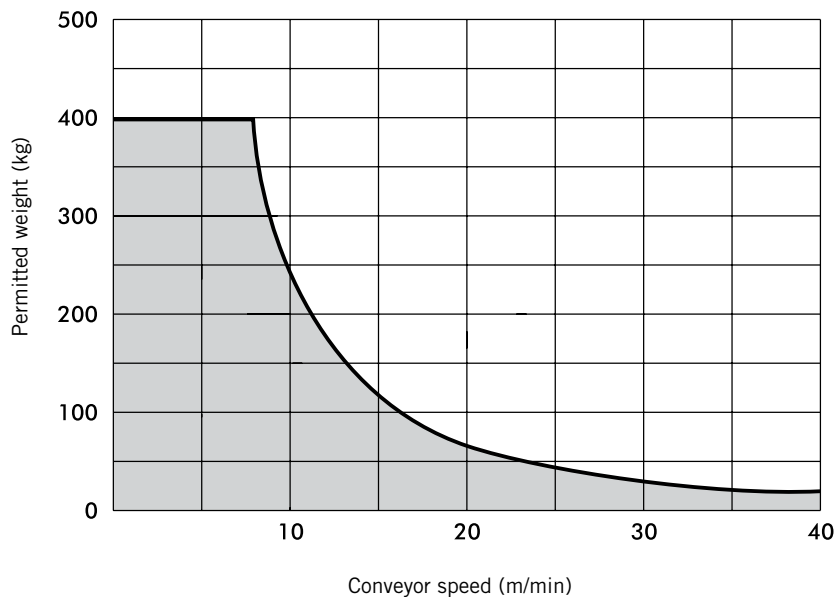

See page 5 for Specifications

Dimensions in mm

**Axial load subject to operating pressure — Type STVDR-50-30**

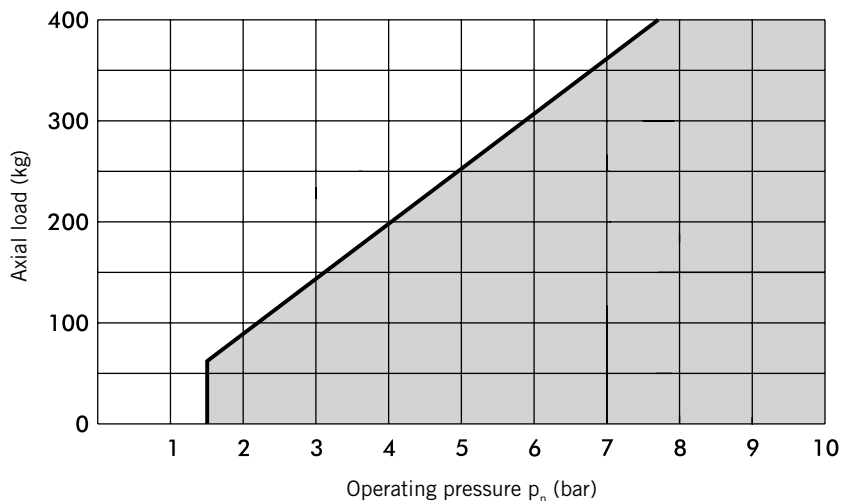

# Pneumatic Stop cylinders

*Vertical version*

*STVDR series*

*Ø 50 mm*

*Loads*

**Product key**

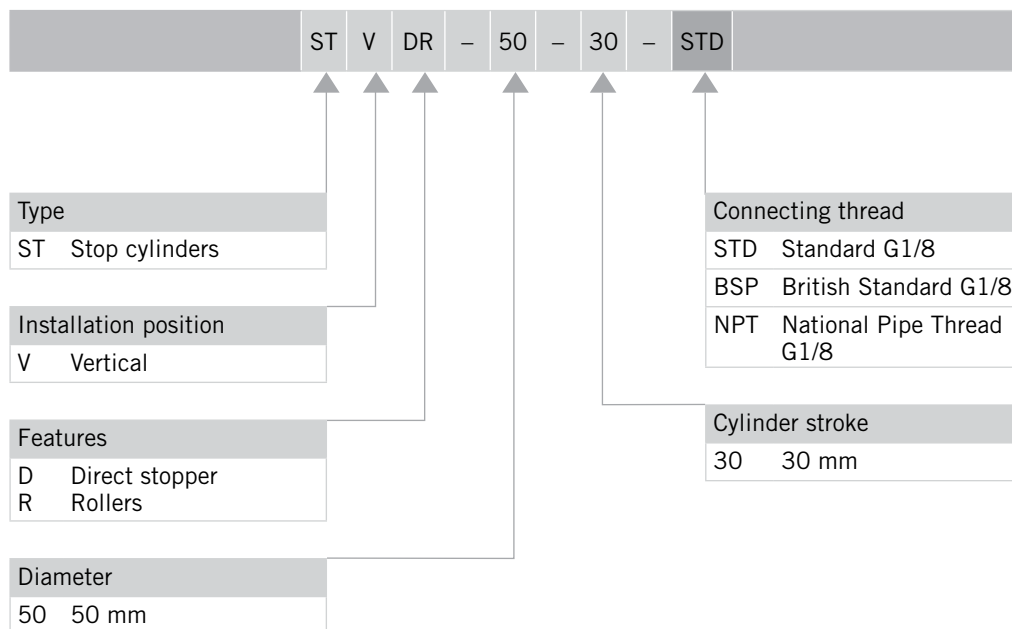

*Order details*



See page 5 for Specifications

Dimensions in mm

# Pneumatic Stop Cylinders

Vertical version

STVD series

Ø 50 mm

Dimensions

## Stop cylinder dimensions Ø 50 — Type STVD-50-30

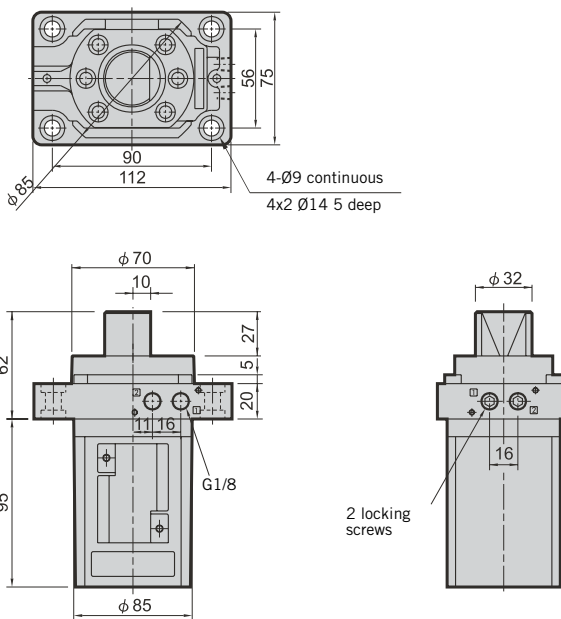

Loads

## Moving mass subject to speed — Type STVD-50-30

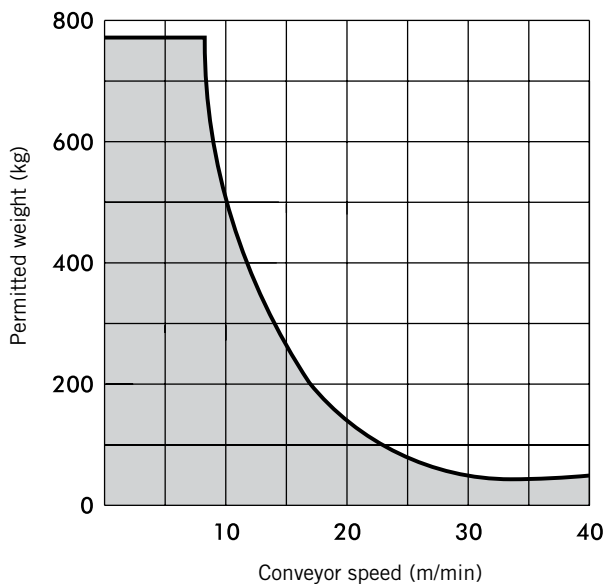

See page 5 for Specifications

Dimensions in mm

**Axial load subject to operating pressure — Type STVD-50-30**

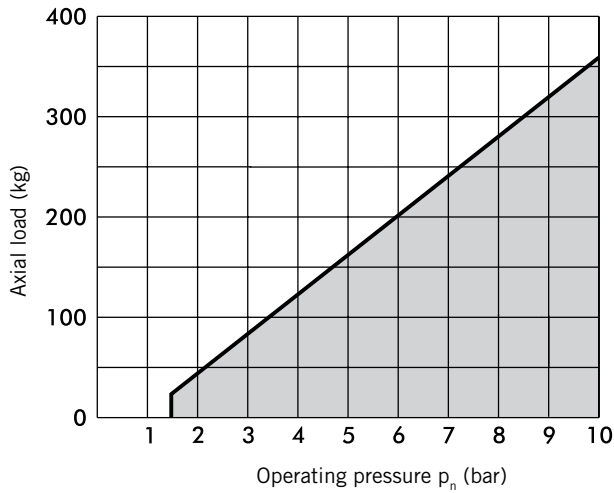

# Pneumatic Stop cylinders

*Vertical version*

*STVD series*

*Ø 50 mm*

*Loads*

**Product key**

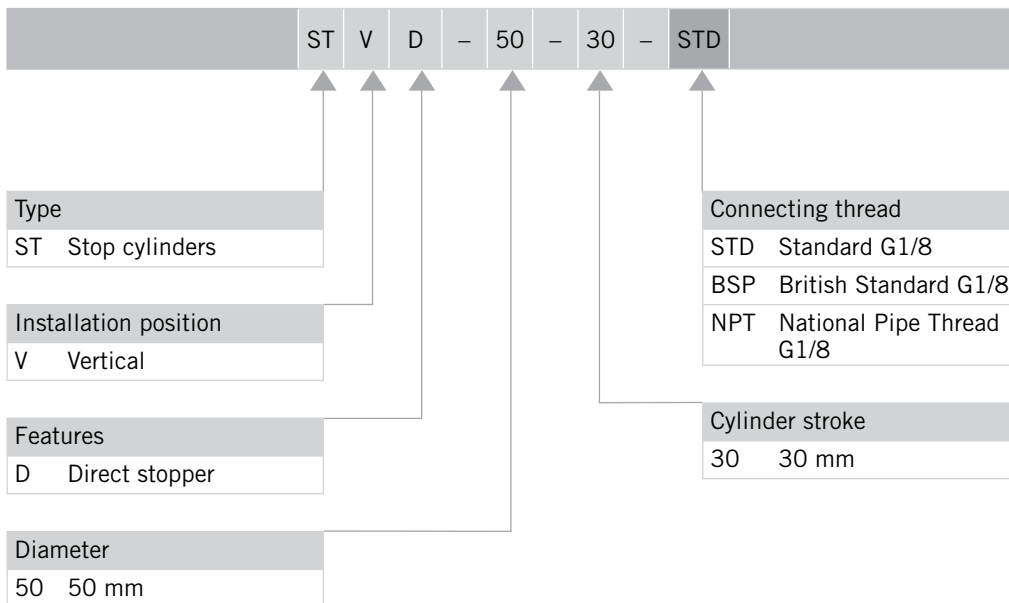

*Order details*



See page 5 for Specifications

Dimensions in mm

# Pneumatic Stop Cylinders

with hydraulic industrial shock absorbers

Horizontal version

STHSR series

Ø 50 mm

Dimensions

Stop cylinder dimensions Ø 50 — Type STHSR-50-50

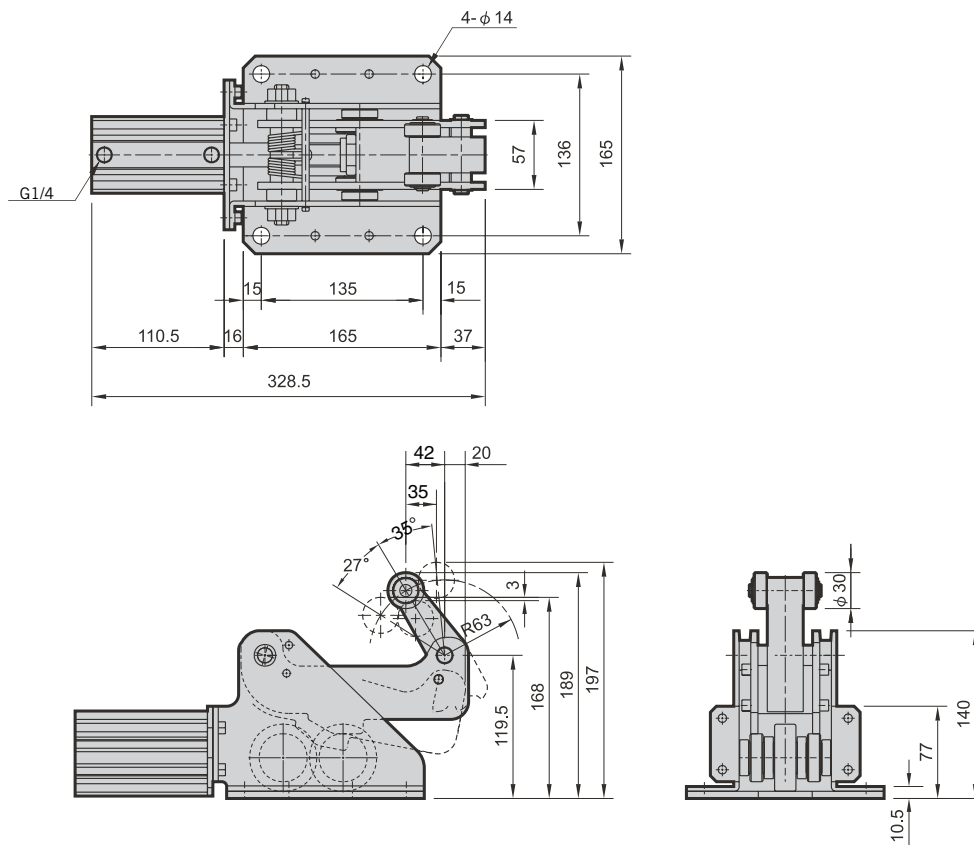

Loads

Moving mass subject to speed — Type STHSR-50-50

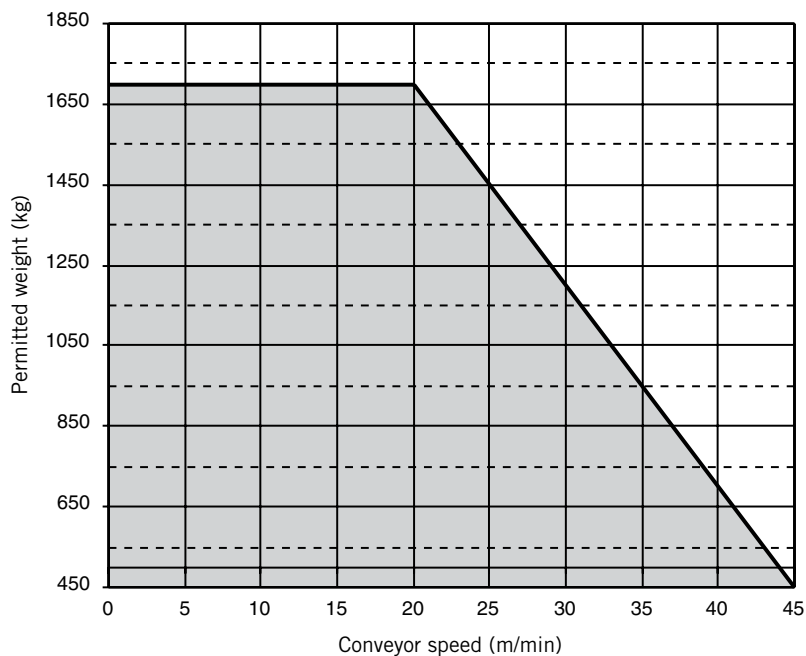

See page 5 for Specifications

Dimensions in mm

**Axial load subject to operating pressure — Type STHSR-50-50**

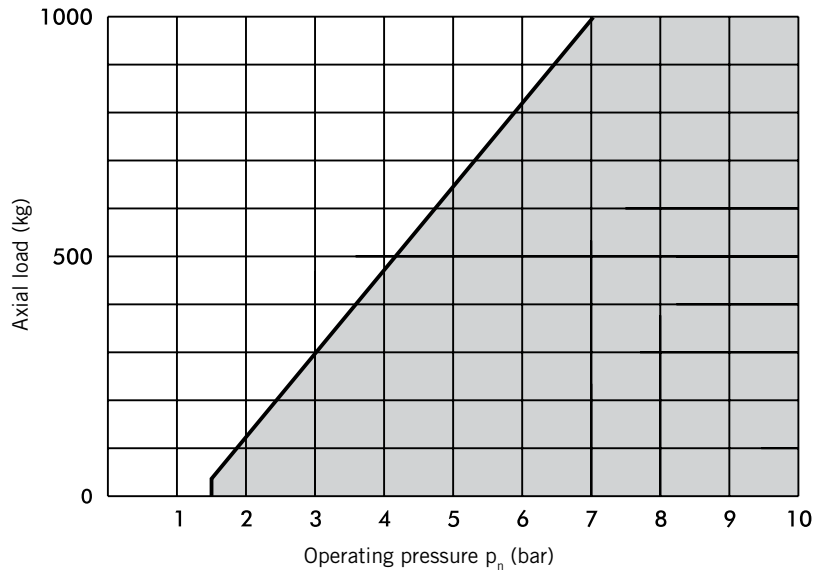

# Pneumatic Stop Cylinders

*with hydraulic industrial shock absorbers*

*Horizontal version*

*STHSR series*

*Ø 50 mm*

*Loads*

**Product key**

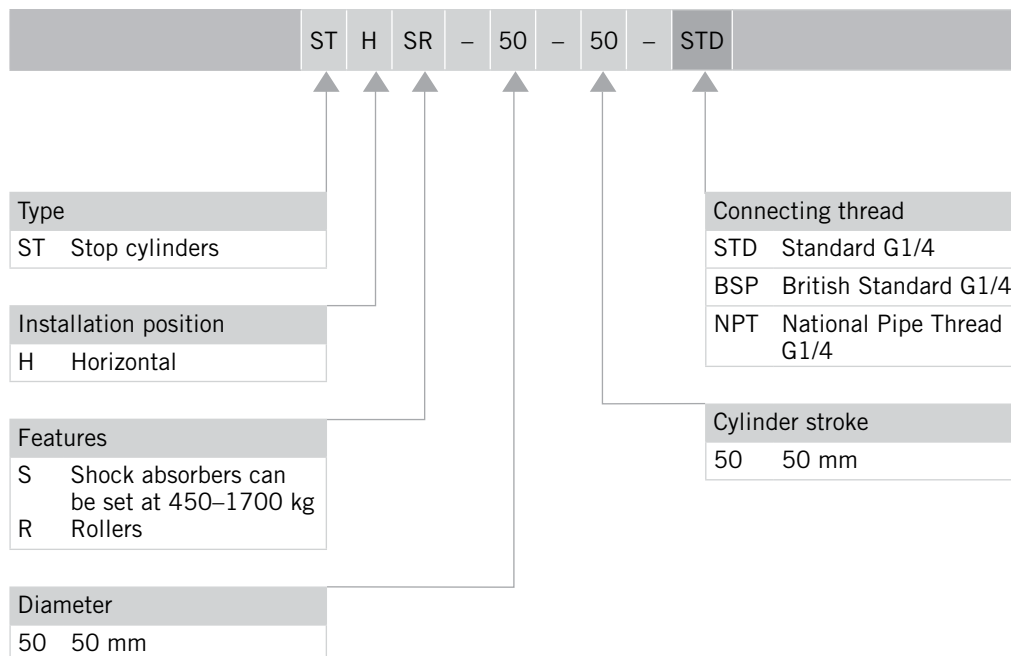

*Order details*



See page 5 for Specifications

Dimensions in mm

# Sales Offices Worldwide

**AE – United Arabien Emirates**

Dubai  
Tel: +971 4 8875600  
parker.me@parker.com

**AR – Argentina**, Buenos Aires  
Tel: +54 3327 44 4129**AT – Austria**, Wiener Neustadt  
Tel: +43 (0)2622 23501-0  
parker.austria@parker.com**AT – Austria**, Wiener Neustadt  
(Europa Oriental)  
Tel: +43 (0)2622 23501 970  
parker.easteurope@parker.com**AT – Austria**, Wiener Neustadt  
Parker Origa Pneumatik GmbH  
Tel: +43 2622 26071-269  
info-hoat-sales.pn@parker-origa.com**AU – Australia**, Castle Hill  
Tel: +61 (0)2-9634 7777**AZ – Azerbaijan**, Baku  
Tel: +994 50 2233 458  
parker.azerbaijan@parker.com**BE/LX – Belgium**, Nivelles  
Tel: +32 (0)67 280 900  
parker.belgium@parker.com**BR – Brazil**, Cachoeirinha RS  
Tel: +55 51 3470 9144**BY – Belarus**, Minsk  
Tel: +375 17 209 9399  
parker.belarus@parker.com**CA – Canada**, Milton, Ontario  
Tel: +1 905 693 3000**CH – Swiss**, Etoy  
Tel: +41 (0) 21 821 02 30  
parker.switzerland@parker.com**CH – Swiss**, Otelfingen  
Parker Origa AG  
Tel: +41 44 846 6860  
info-hoch-sales@parker-origa.com**CN – China**, Shanghai  
Tel: +86 21 5031 2525**CZ – Czechia**, Klecany  
Tel: +420 284 083 111  
parker.czechrepublic@parker.com**DE – Germany**, Kaarst  
Tel: +49 (0)2131 4016 0  
parker.germany@parker.com**DK – Denmark**, Ballerup  
Tel: +45 43 56 04 00  
parker.denmark@parker.com**ES – Spain**, Madrid  
Tel: +34 902 33 00 01  
parker.spain@parker.com**FI – Finland**, Vantaa  
Tel: +358 (0)20 753 2500  
parker.finland@parker.com**FR – France**  
Tel: +33 (0)4 50 25 80 25  
parker.france@parker.com**FR – France**, Courtaboeuf Cedex  
Parker Origa SAS  
Tel: +33 1 69 29 22 00  
info-hofr-sales@parker-origa.com**GR – Greece**, Atenas  
Tel: +30 210 933 6450  
parker.greece@parker.com**HK – Hong Kong**  
Tel: +852 2428 8008**HU – Hungary**, Budapest  
Tel: +36 1 220 4155  
parker.hungary@parker.com**IE – Ireland**, Dublin  
Tel: +353 (0)1 466 6370  
parker.ireland@parker.com**IN – India**, Mumbai  
Tel: +91 22 6513 7081-85**IT – Italy**, Corsico (MI)  
Tel: +39 02 45 19 21  
parker.italy@parker.com**IT – Italy**, Pioltello (MI)  
Parker Origa SRL  
Tel: +39 02 92 16 65 53  
info-hoit-sales@parker-origa.com**JP – Japan**, Fujisawa  
Tel: +(81) 4 6635 3050**KR – Korea**, Seúl  
Tel: +82 2 559 0400**KZ – Kazakhstan**, Almaty  
Tel: +7 7272 505 800  
parker.easteurope@parker.com**LV – Latvia**, Riga  
Tel: +371 6 745 2601  
parker.latvia@parker.com**MX – Mexico**, Apodaca  
Tel: +52 81 8156 6000**MY – Malaysia**, Subang Jaya  
Tel: +60 3 5638 1476**MY – Malaysia**, Penang  
Parker Origa Sdn Bhd  
Tel: +60 4 508 10 11  
info-hosg-sales@parker-origa.com**NL – Netherlands**, Oldenzaal  
Tel: +31 (0)541 585 000  
parker.nl@parker.com**NL – Netherlands**, SL Moerdijk  
Parker Origa B.V.  
Tel: +31 168 356 600  
info-honl-sales@parker-origa.com**NO – Norway**, Ski  
Tel: +47 64 91 10 00  
parker.norway@parker.com**NO – Norway**, Drammen  
Parker Origa AS  
Tel: +47 3 288 08 40  
info-hose-sales@parker-origa.com**NZ – New Zealand**  
Mt Wellington  
Tel: +64 9 574 1744**PL – Poland**, Varsovia  
Tel: +48 (0)22 573 24 00  
parker.poland@parker.com**PT – Portugal**, Leca da Palmeira  
Tel: +351 22 999 7360  
parker.portugal@parker.com**RO – Romania**, Bucarest  
Tel: +40 21 252 1382  
parker.romania@parker.com**RU – Russia**, Moscow  
Tel: +7 495 645-2156  
parker.russia@parker.com**SE – Sweden**, Spånga  
Tel: +46 (0)8 59 79 50 00  
parker.sweden@parker.com**SE – Sweden**, Kungsör  
Parker Origa AB  
Tel: +46 227 411 00  
info-hose-sales@parker-origa.com**SG – Singapor**  
Tel: +65 6887 6300**SG – Singapor**  
Parker Origa PTE Ltd.  
Tel: +65 6483 2959  
info-hose-sales@parker-origa.com**SK – Slovakia**, Banská Bystrica  
Tel: +421 484 162 252  
parker.slovakia@parker.com**SI – Slovenia**, Novo Mesto  
Tel: +386 7 337 6650  
parker.slovenia@parker.com**TH – Thailand**, Bangkok  
Tel: +662 717 8140**TR – Turkey**, Istanbul  
Tel: +90 216 4997081  
parker.turkey@parker.com**TW – Taiwan**, Taipei  
Tel: +886 2 2298 8987**UA – Ukraine**, Kiev  
Tel: +380 44 494 2731  
parker.ukraine@parker.com**UK – United Kingdom**, Gloucester  
Parker Origa Ltd.  
Tel: +44 8700 600655  
info-hogb-sales@parker-origa.com**UK – United Kingdom**, Warwick  
Tel: +44 (0)1926 317 878  
parker.uk@parker.com**US – United States of America**,  
Cleveland  
Tel: +1 216 896 3000**US – United States of America**  
Parker Origa Corporation  
Tel: +1 630 871 830-0  
info-hous-sales@parker-origa.com**VE – Venezuela**, Caracas  
Tel: +58 212 238 5422**ZA – South Africa**,  
Kempton Park  
Tel: +27 (0)11 961 0700  
parker.southafrica@parker.com**Parker-Origa GmbH**

Industriestr. 8  
70794 Filderstadt, Deutschland  
Tel. +49 7185 17030  
Fax +49 7158 64870  
www.parker-origa.com

