





Overview

System	Fig.	Symbol	Series	Page
Non-rotating Double acting without cushioning For contactless position sensing			FZG6... FZK6...	86-99
Linear guide, U-Form for cylinders to ISO15552, ISO6432 Ø8-100 mm			FEUG..	100-106
Linear guide, H-Form for cylinders to ISO15552 Ø32-100 mm			FEHG... FEHK...	107-112

Guided Cylinders

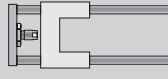
Series

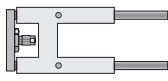
*FZG6... **

*FZK6... ***

Ø 20-50 mm

* Guided Cylinders with Sliding Guidance

** Guided Cylinders with Recirculating Ball Bearing Guidance

Linear Guides

Series

*FEUG... **

*FEHG... **

*FEHK... ***

Ø 8 – 100 mm

* Linear Guide
– with plain bearings

** Linear Guide
– with ball bearings

Guided Cylinder

Series
 FZG6...*
 FZK6...**
 Ø 20-50 mm

- * Guided Cylinders with Sliding Guidance
- ** Guided Cylinders with Recirculating Ball Bearing Guidance

Depending on stroke length, one or more magnetic switches can be mounted in the slots in the cylinder profile for contactless position sensing of the end and intermediate piston positions. Especially recommended are RST or EST magnetic switches which can be directly fitted in the T-slots in the cylinder.

Included in delivery:
 1 guided cylinder
 4 centring bushes (see table)
 2 screw plugs, replaceable, preassembled

Cylinder switches are not included - please order separately.

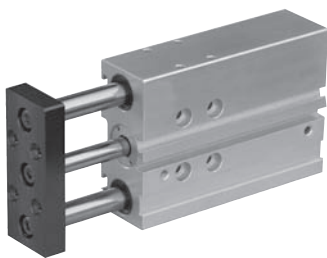

Characteristics

Characteristics	Symbol	Unit	Description					
General								
Type	Guided cylinder							
Series	FZG/FZK							
System FZG6..., FZK6...	Double-acting without end cushioning for contactless position sensing							
Connection	See dimensional drawings							
Connection	Thread							
Ambient temperature range	$T_{min/max}$	°C	FZG: -20 to +80					Note: When using below freezing point (°C) it is necessary to consult us
	$T_{min/max}$	°C	FZK: -5 to +60					
Medium temperature range	T_{max}	°C	+80					
Weight (Mass)	See Table							
Installation	In any position							
Medium	Filtered and lubricated or filtered, unlubricated compressed air							
Lubrication	Initial lubrication with grease during assembly							
Materials								
Housing	Aluminium, anodized							
Front/rear end cap	Aluminium, anodized							
Piston rod	Steel, high-alloy							
Carrier plate	Aluminium, high-strength, anodized							
Guide rod	FZG: steel, high-alloy FZK: steel, brushed							
Pneumatic Characteristics								
Nominal pressure	p_n	bar	6					
Operating pressure range								
Ø 20	$p_{min/max}$	bar	2 – 10					
Ø 25-40	1,5 – 10							
Ø 50	1 – 10							
Piston diameter	mm	20	25	32	40	50		
Port size		M5	G1/8	G1/8	G1/8	G1/4		
Piston rod diameter	mm	10	12	12	16	20		
Guide rod diameter FZG	mm	14	16	20	20	25		
Guide rod diameter FZK	mm	12	14	16	16	20		
Stroke lengths	mm	See table order instructions page 99						
Net force and air consumption	See page 9							
Cushioning	Elastomer cushioning at both ends							
Lateral force Torque	max.	N Nm	See diagrams					

Number of Centring Bushes FZG / FZK

Type	FZ-020	FZ-025	FZ-032	FZ-040	FZ-050
AH-7	2	2	-	-	-
AH-9	2	2	2	2	-
AH-12	-	-	2	2	4

Weight and Moving Mass

Guided Cylinders with Sliding Guidance - Series FZG

Weight (Mass) [kg]

Stroke [mm]	Size [mm]				
	Ø 20	Ø 25	Ø 32	Ø 40	Ø 50
10	-	-	-	-	-
20	0.594	0.950	1.375	-	-
25	0.632	1.030	1.425	1.690	2.668
30	0.672	1.047	1.515	-	-
40	0.853	1.185	1.666	-	-
50	0.945	1.295	1.815	2.110	3.320
80	1.192	1.620	2.324	2.718	4.266
100	1.354	1.830	2.612	3.057	4.762
125	-	-	3.066	3.575	5.562
160	-	-	3.628	4.182	6.478
200	-	-	4.225	4.897	7.527

Moving Mass [kg]

Stroke [mm]	Size [mm]				
	Ø 20	Ø 25	Ø 32	Ø 40	Ø 50
10	-	-	-	-	-
20	0.303	0.453	0.735	-	-
25	0.317	0.471	0.763	0.860	1.474
30	0.332	0.489	0.791	-	-
40	0.421	0.556	0.847	-	-
50	0.451	0.592	0.903	1.017	1.719
80	0.538	0.701	1.156	1.291	2.169
100	0.597	0.774	1.268	1.416	2.365
125	-	-	1.502	1.668	2.758
160	-	-	1.698	1.888	3.102
200	-	-	1.922	2.139	3.495

Guided Cylinders with Recirculating Ball Bearing Guidance - Series FZK

Weight (Mass) [kg]

Stroke [mm]	Size [mm]				
	Ø 20	Ø 25	Ø 32	Ø 40	Ø 50
10	-	-	-	-	-
20	0.544	0.848	1.192	-	-
25	0.583	0.887	1.241	1.494	2.380
30	0.622	0.940	1.305	-	-
40	0.766	1.062	1.440	-	-
50	0.845	1.163	1.573	1.877	2.935
80	1.078	1.464	2.019	2.404	3.766
100	1.225	1.660	2.274	2.698	4.207
125	-	-	2.656	3.150	4.880
160	-	-	3.120	4.201	5.701
200	-	-	3.650	4.315	6.632

Moving Mass [kg]

Stroke [mm]	Size [mm]				
	Ø 20	Ø 25	Ø 32	Ø 40	Ø 50
10	-	-	-	-	-
20	0.257	0.387	0.564	-	-
25	0.268	0.402	0.584	0.680	1.161
30	0.280	0.417	0.603	-	-
40	0.347	0.469	0.642	-	-
50	0.370	0.498	0.681	0.795	1.340
80	0.440	0.586	0.852	0.987	1.655
100	0.486	0.644	0.931	1.079	1.798
125	-	-	1.088	1.254	2.072
160	-	-	1.225	1.415	2.323
200	-	-	1.381	1.598	2.610

Speeds

Piston diameter [mm]	Ø 20	Ø 25	Ø 32	Ø 40	Ø 50
Stroke [mm]	100	100	200	200	200
Extension speed max. (v_{maxA}) [m/s]	0.8	0.8	0.8	0.8	0.6
Retraction speed max. (v_{maxL}) [m/s]	0.8	0.8	0.8	0.8	0.6

End Cushioning

Drives with end cushioning designation „2000/6000“ are fitted with an elastomer end cushioning system. The permissible impact and residual forces shown below must not be exceeded; they are valid for specific mass/speed combinations (for calculation principles, see below).

Shock-Absorbing Capability of the Elastomer End Cushioning

The permissible kinetic impact or residual energy at the end stop must not be exceeded, otherwise mechanical failure of the cylinder can occur (deformation, breakage, change in running characteristics). The permissible kinetic impact energy is calculated with the following formula:

$$E_{\text{per}} = \frac{1}{2} (m_{\text{own}} + m_{\text{load}}) \times v^2$$

E_{per} = permissible kinetic impact energy [Nm]

m_{own} = moving own mass [kg]

m_{load} = moving load mass [kg]

v = impact speed [m/s]

From this value the permissible operating conditions can be calculated with the following forms of the equation:

Permissible impact speed:

$$v_{\text{per}} = \frac{2 \times E_{\text{per}}}{m_{\text{own}} + m_{\text{load}}}$$

Maximum permissible mass:

$$m_{\text{load}} = \frac{2 \times E_{\text{per}}}{v^2} - m_{\text{own}}$$

Piston diameter (mm)	Ø 20	Ø 25	Ø 32	Ø 40	Ø 50
E_{per} (Nm)	0.14	0.35	0.40	0.52	0.64

Permissible Lateral Load for Series FZG (Guided Cylinder with Sliding Guidance)

Permissible Loading in dependence on Lever Arm/Net Load

Application Example: Lifting Cylinder

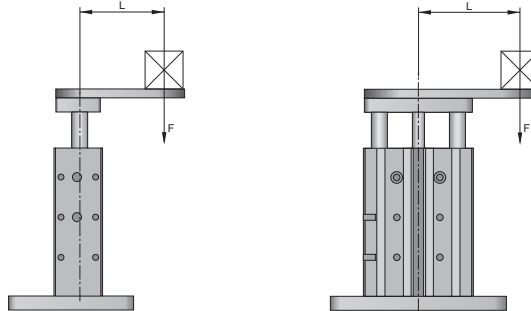

F = lateral force (N)
L = lever arm (mm)

Series FZG6020 / 6025 (Stroke 30 mm)

Series	Lever Arm L (mm)									
	0	25	45	50	75	100	125	150	175	200
① FZG6020	85	85	85	70	49	37	30	23	20	18
② FZG6025	132	132	132	120	80	60	49	40	33	30

Series FZG6020 / 6025 (Stroke 40 - 100 mm)

Series	Lever Arm L (mm)									
	0	25	50	75	100	125	130	150	175	200
① FZG6020	85	85	85	85	85	85	85	85	85	79
② FZG6025	132	132	132	132	132	132	132	132	112	98

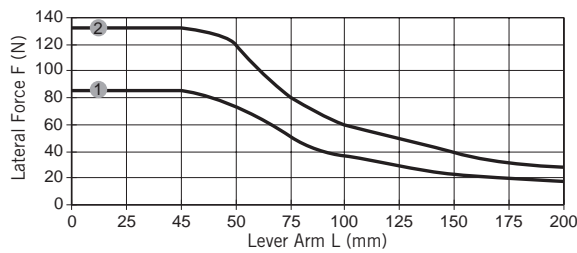

① = FZG020
② = FZG025

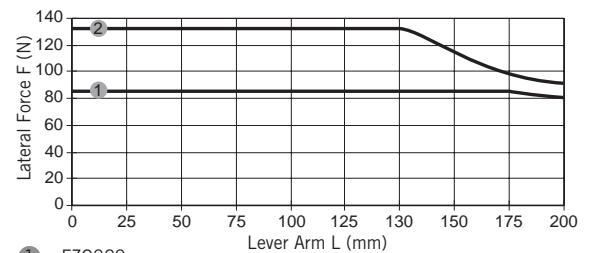

① = FZG020
② = FZG025

Series FZG6032, 6040, 6050 (Stroke 50 mm)

Series	Lever Arm L (mm)									
	0	25	50	55	75	100	125	150	175	200
① FZG6032	240	240	240	240	240	220	180	150	130	120
② FZG6040	410	410	410	410	300	220	180	150	130	120
③ FZG6050	650	650	650	650	500	350	300	250	210	190

Series FZG6032, 6040, 6050 (Stroke 80 - 100 mm)

Series	Lever Arm L (mm)									
	0	25	50	55	75	100	125	150	175	200
① FZG6032	240	240	240	240	240	220	180	150	130	120
② FZG6040	410	410	410	410	300	220	180	150	130	120
③ FZG6050	610	610	610	610	500	370	300	250	210	190

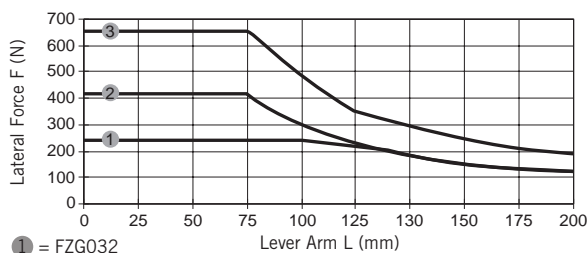

① = FZG032
② = FZG040
③ = FZG050

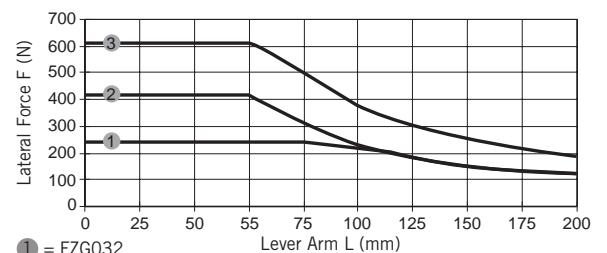

① = FZG032
② = FZG040
③ = FZG050

Permissible Lateral Load for Series FZK (Guided Cylinder with Recirculating Ball Bearing Guidance)

Permissible Loading in dependence on Lever Arm/Net Load

Application Example: Lifting Cylinder

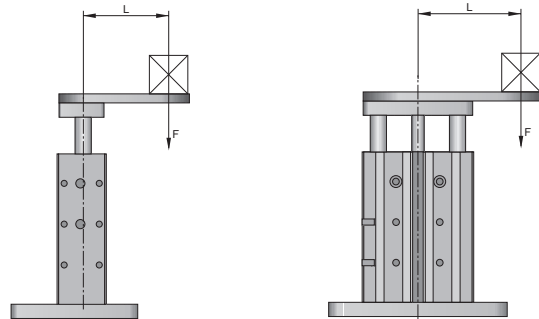

F = lateral force (N)
L = lever arm (mm)

Series FZK6020 / 6025 (Stroke 30 mm)

Series	Lever Arm L (mm)									
	0	20	25	50	75	100	125	150	175	200
Lateral Force F (N)										
① FZK6020	82	82	70	37	23	18	13	11	10	9
② FZK6025	132	132	132	70	47	33	28	22	20	18

Series FZK6020 / 6025 (Stroke 40 - 100 mm)

Series	Lever Arm L (mm)									
	0	20	25	50	75	100	125	150	175	200
Lateral Force F (N)										
① FZK6020	82	82	82	82	70	50	40	37	30	27
② FZK6025	132	132	132	132	90	66	52	45	38	35

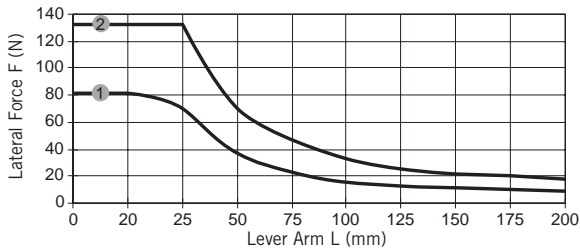

① = FZK020
② = FZK025

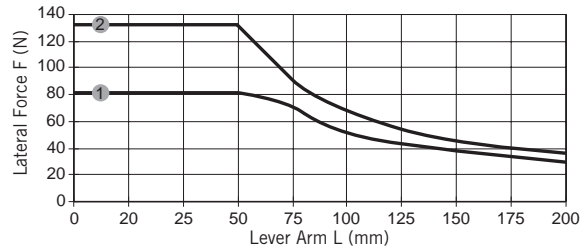

① = FZK020
② = FZK025

Series FZK6032, 6040, 6050 (Stroke 50 mm)

Series	Lever Arm L (mm)									
	0	20	25	50	75	100	125	150	175	200
Lateral Force F (N)										
① FZK6032	240	240	175	85	75	65	50	48	40	25
② FZK6040	420	420	160	85	75	65	50	48	40	25
③ FZK6050	650	650	250	125	90	80	60	52	50	48

Series FZK6032, 6040, 6050 (Stroke 80 - 100 mm)

Series	Lever Arm L (mm)									
	0	20	25	50	75	100	125	150	175	200
Lateral Force F (N)										
① FZK6032	240	240	240	240	200	150	120	100	85	80
② FZK6040	420	420	420	310	200	150	120	100	85	80
③ FZK6050	650	650	650	500	340	265	205	160	130	125

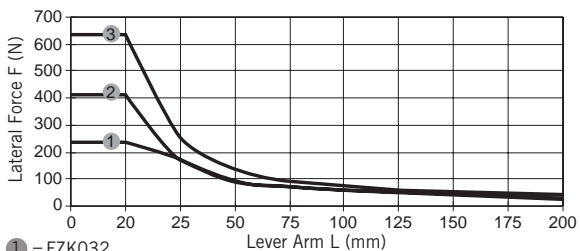

① = FZK032
② = FZK040
③ = FZK050

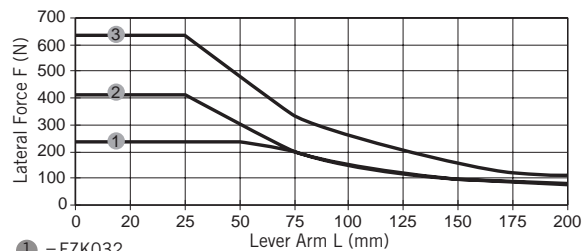

① = FZK032
② = FZK040
③ = FZK050

Maximum Net Load / permissible Torque – Series FZK and FZG

Maximum Net Load F [N] for Sliding and Recirculating Ball Bearing Guidance

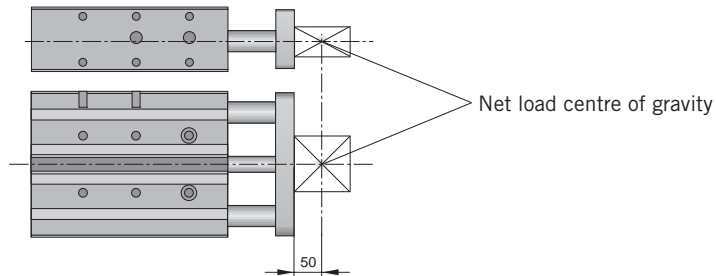

Series	Piston- Ø	Maximum Net Load F (N) per stroke (mm)										
		10	20	25	30	40	50	80	100	125	160	200
FZG6020	20	–	67	64	61	110	103	86	77	–	–	–
FZK6020	20	–	45	39	35	91	88	80	75	–	–	–
FZG6025	25	–	121	116	112	123	115	96	86	–	–	–
FZK6025	25	–	88	86	84	100	97	89	85	–	–	–
FZG6032	32	–	188	180	173	161	150	166	150	168	146	127
FZK6032	32	–	120	118	116	112	109	134	128	144	135	126
FZG6040	40	–	–	180	–	–	150	166	150	168	146	127
FZK6040	40	–	–	118	–	–	109	134	128	144	135	126
FZG6050	50	–	–	257	–	–	216	234	212	229	200	174
FZK6050	50	–	–	182	–	–	168	201	193	211	199	188

Maximum Torsion Load M [Nm] for Sliding and Recirculating Ball Bearing Guidance

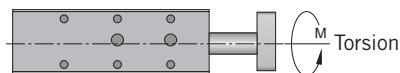

Series	Piston- Ø	Maximum Torsion Load M (Nm) per stroke (mm)										
		10	20	25	30	40	50	80	100	125	160	200
FZG6020	20	–	1.85	1.75	1.70	3.00	2.80	2.35	2.10	–	–	–
FZK6020	20	–	1.30	1.13	1.01	2.64	2.56	2.34	2.23	–	–	–
FZG6025	25	–	4.15	3.95	3.80	4.20	3.90	3.25	2.90	–	–	–
FZK6025	25	–	3.00	2.92	2.85	3.40	3.30	3.02	2.89	–	–	–
FZG6032	32	–	7.30	7.00	6.70	6.20	5.80	6.40	5.80	6.50	5.70	5.00
FZK6032	32	–	4.70	4.60	4.55	4.40	4.25	5.25	5.00	5.60	5.25	4.90
FZG6040	40	–	–	7.90	–	–	6.55	7.25	6.55	7.35	6.40	5.55
FZK6040	40	–	–	5.20	–	–	4.80	5.90	5.65	6.35	5.95	5.55
FZG6050	50	–	–	14.15	–	–	11.85	12.85	11.65	12.55	11.00	9.60
FZK6050	50	–	–	10.00	–	–	9.30	11.00	10.60	11.60	11.00	10.30

Permissible Impact Energy – Series FZG (Guided Cylinder with Sliding Guidance)

Application as Stop Cylinder / Only Sliding Guidance

Series	Impact Speed v [m/min]								
	0	5	10	15	20	25	30	35	40
	Impact Mass m [kg]								
① FZG020	47	47	47	21	12	8	5	4	3
② FZG025	75	75	75	31	18	12	8	6	4
③ FZG032	210	210	210	90	50	40	30	20	10
④ FZG040	270	270	270	110	70	50	40	25	15
⑤ FZG050	450	450	450	200	120	70	50	30	20

Permissible Impact Energy – Series FZG6020, FZG6025

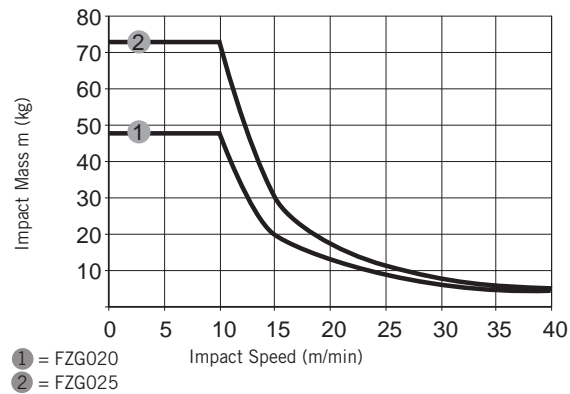

Permissible Impact Energy – Series FZG6032, FZG6040, FZG6050

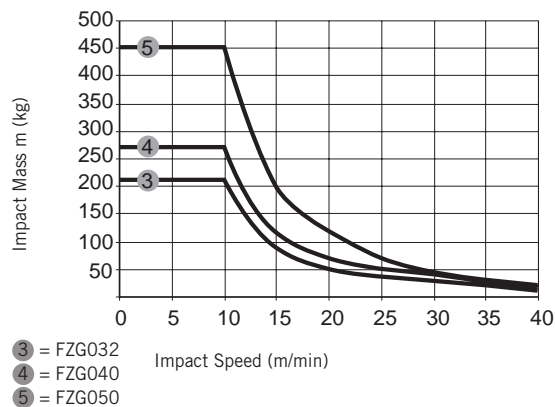

Torsion Play of Recirculating Ball Bearing Guidance and Sliding Guidance (retracted mode, unloaded)

Series	Torsion Play [°]				
	Ø 20	Ø 25	Ø 32	Ø 40	Ø 50
FZG6000	0.09	0.09	0.07	0.06	0.05
FZK6000	0.08	0.08	0.07	0.05	0.05

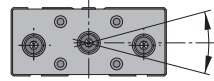

Torsion / Play for Series FZK and FZG

For accuracy of guidance, apart from torsion play, the torsion of the rod itself must be taken into account.

Deflection of Piston Rod with Sliding Guidance FZG and Recirculating Ball Bearing Guidance FZK (bearing play)

Series	Stroke [mm]	Deflection of Piston Rod				
		Ø 20	Ø 25	Ø 32	Ø 40	Ø 50
FZG6000	50	0.11	0.10	0.13	0.13	0.12
FZK6000	50	0.08	0.08	0.08	0.08	0.08

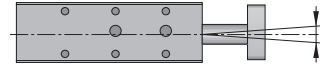

Deflection of Piston Rod through Bearing Play + Lateral Force General formula for the deflection of the piston rod under load is:

$$f = \frac{F_{load} \times L_{rod}^3}{6 \times E_{rod} \times I_{rod}}$$

The total deflection of the piston rod is made up of the sum of:
 – the deflection caused by bearing play and
 – the deflection caused by rod distortion under load.

- F_{load} = lateral force applied
- L_{rod} = free bending length of rod
- E_{rod} = modulus of elasticity of piston rod material
- I_{rod} = surface torque of piston rod

Dimensions - Series FZG6020 to 6032 and Series FZK6020 to 6032

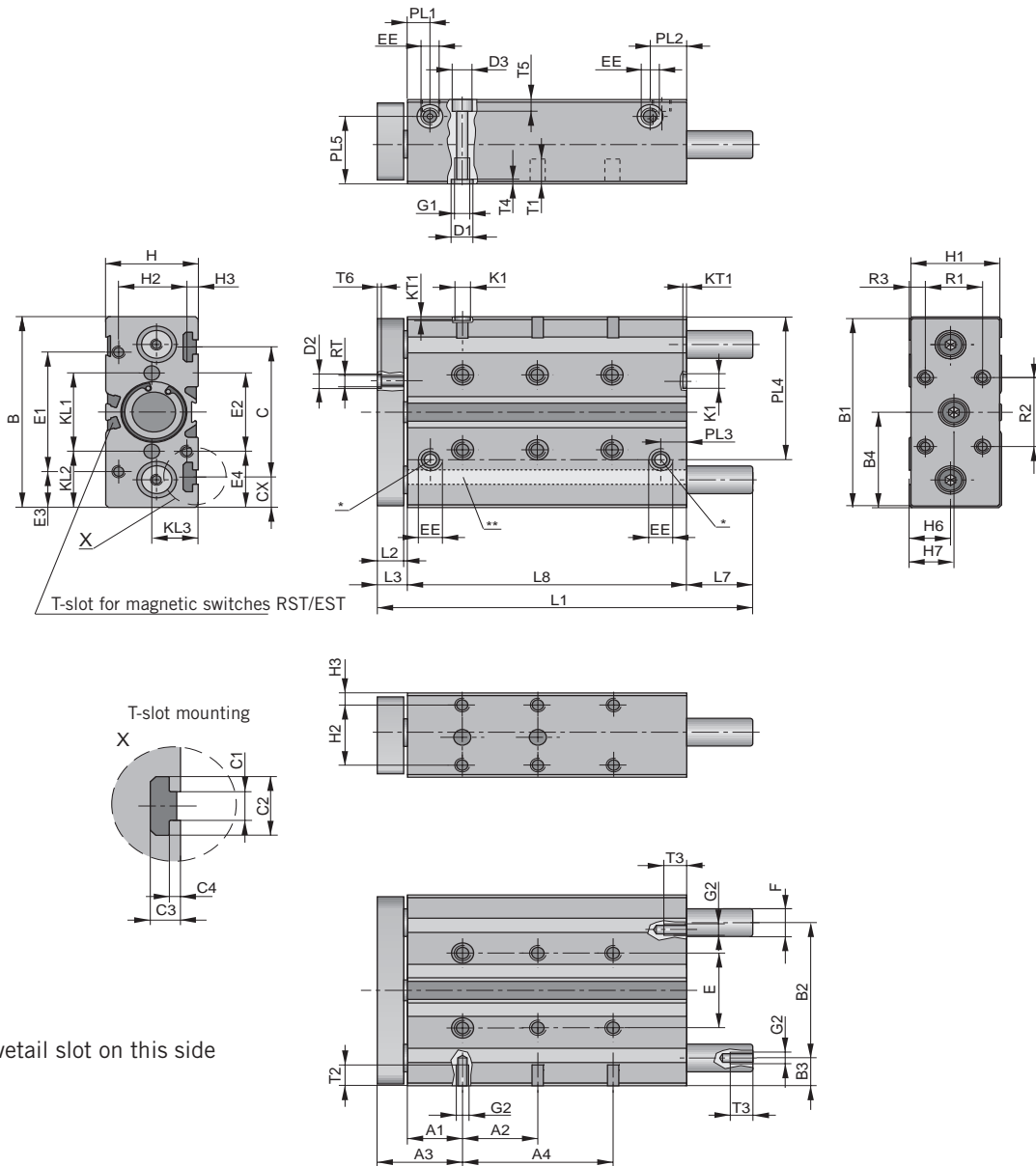

* Screw plugs
 ** On $\varnothing 20$, dovetail slot on this side

Dimensions Table (mm) – Series FZK(G) 6020 to 6032

Stroke	External Dimensions																							
	L1			L2			L3			L7			L8			B			B1			B2		
	$\varnothing 20$	$\varnothing 25$	$\varnothing 32$	$\varnothing 20$	$\varnothing 25$	$\varnothing 32$	$\varnothing 20$	$\varnothing 25$	$\varnothing 32$	$\varnothing 20$	$\varnothing 25$	$\varnothing 32$	$\varnothing 20$	$\varnothing 25$	$\varnothing 32$	$\varnothing 20$	$\varnothing 25$	$\varnothing 32$	$\varnothing 20$	$\varnothing 25$	$\varnothing 32$	$\varnothing 20$	$\varnothing 25$	$\varnothing 32$
20	75	93	101	12	12	14	14	14	16	-	13.4	17	61	65.6	68	83	95	110	81	93	108	58	68	78
25	80	98	106										-	13.4	17	66	70.6	73						
30	85	103	111										-	13.4	17	71	75.6	78						
40	121	123	121							26	-	17	81	85.6	88									
50	131	133	131							26	-	17	91	95.6	98									
80	161	163	179							26	-	35	121	125.6	128									
100	181	183	199							26	-	35	141	145.6	148									
125	-	-	244							-	-	55	-	-	173									
160	-	-	279							-	-	55	-	-	208									
200	-	-	319							-	-	55	-	-	248									

Stroke	External Dimensions																							
	B3			B4			H			H1			H6			H7			F _{h6} (FZK)			F _{h8} (FZG)		
	Ø20	Ø25	Ø32	Ø20	Ø25	Ø32	Ø20	Ø25	Ø32	Ø20	Ø25	Ø32	Ø20	Ø25	Ø32	Ø20	Ø25	Ø32	Ø20	Ø25	Ø32	Ø20	Ø25	Ø32
20 to 200	12.5	13.5	16	41.5	47.5	55	36	44	49	34	42	47	17	20	22	18.5	24	23.5	12	14	16	14	16	20

Stroke	Mounting Dimensions																							
	E ±0.1			E1 ±0.1			E2 ±0.1			E3			E4			A1 ±0.1			A2 ±0.1			A3		
	Ø20	Ø25	Ø32	Ø20	Ø25	Ø32	Ø20	Ø25	Ø32	Ø20	Ø25	Ø32	Ø20	Ø25	Ø32	Ø20	Ø25	Ø32	Ø20	Ø25	Ø32	Ø20	Ø25	Ø32
20	30	35	43	-	64	70	74	35	45	-	15.5	20	4.5	30	32.5	26	26	29	-	-	-	40	40	45
25																			20	20	20			
30																			20	20	20			
40																			20	20	20			
50																			40	40	40			
80																			40	40	40			
100																			40	40	40			
125																								40
160																								40
200																								40

Stroke	Mounting Dimensions																							
	A4 ±0.1			H2 ±0.1			H3			R1 ±0.1			R2 ±0.1			R3			RT			G1		
	Ø20	Ø25	Ø32	Ø20	Ø25	Ø32	Ø20	Ø25	Ø32	Ø20	Ø25	Ø32	Ø20	Ø25	Ø32	Ø20	Ø25	Ø32	Ø20	Ø25	Ø32	Ø20	Ø25	Ø32
20	-	-	-	-	33.5	37	4.5	4.5	6	20	20	30	30	40	40	7	12	8.5	M5	M6	M6	M6	M6	M8
25	-	-	-																					
30	30	-	-																					
40	-	-	-																					
50	-	-	-																					
80	-	-	-																					
100	80	80	80																					
125	-	-	80																					
160	-	-	120																					
200	-	-	160																					

Stroke	Mounting Dimensions																		
	G2			T1			T2			T3			T5			ØD3			
	Ø20	Ø25	Ø32	Ø20	Ø25	Ø32	Ø20	Ø25	Ø32	Ø20	Ø25	Ø32	Ø20	Ø25	Ø32	Ø20	Ø25	Ø32	
20 to 200	M5	M6	M6	12	14	15	10	12	10	10	12	12	12	5.7	5.7	6.8	9	9	11

Stroke	Air Connection																	
	EE			PL1			PL2			PL3			PL4			PL5		
	Ø20	Ø25	Ø32	Ø20	Ø25	Ø32	Ø20	Ø25	Ø32	Ø20	Ø25	Ø32	Ø20	Ø25	Ø32	Ø20	Ø25	Ø32
20 to 200	M5	G1/8	G1/8	15.3	13.5	12.2	12	17	19.5	12	13	13.5	55	70	81	29	35	39

Stroke	T-Slot Mounting																	
	C			C1			C2			C3			C4			CX		
	Ø20	Ø25	Ø32	Ø20	Ø25	Ø32	Ø20	Ø25	Ø32	Ø20	Ø25	Ø32	Ø20	Ø25	Ø32	Ø20	Ø25	Ø32
20 to 200	55	66	75	6.15	8.2	8.2	12	16.7	16.7	5.5	8	8	1.2	3	3	17.5	14.5	17.5

Stroke	Centring Bush Holes																										
	ØD1 ^{H7}			ØD2 ^{H7}			ØK1 ^{H7}			KL1			KL2			KL3			KT1			T4			T6		
	Ø20	Ø25	Ø32	Ø20	Ø25	Ø32	Ø20	Ø25	Ø32	Ø20	Ø25	Ø32	Ø20	Ø25	Ø32	Ø20	Ø25	Ø32	Ø20	Ø25	Ø32	Ø20	Ø25	Ø32	Ø20	Ø25	Ø32
20 to 200	9	9	12	9	9	9	7	7	9	31	37	45	26	29	32.5	18	22	24.5	1.6	1.6	2.1	2.1	2.1	2.6	2.1	2.1	2.1

Dimensions – Series FZG6040 / 6050 and Series FZK6040 / 6050

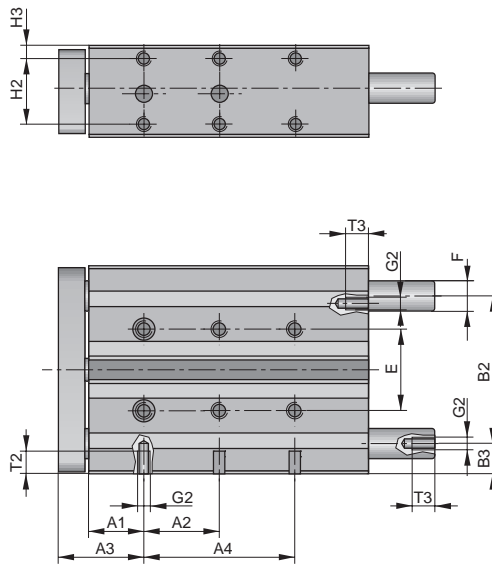
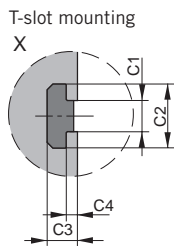
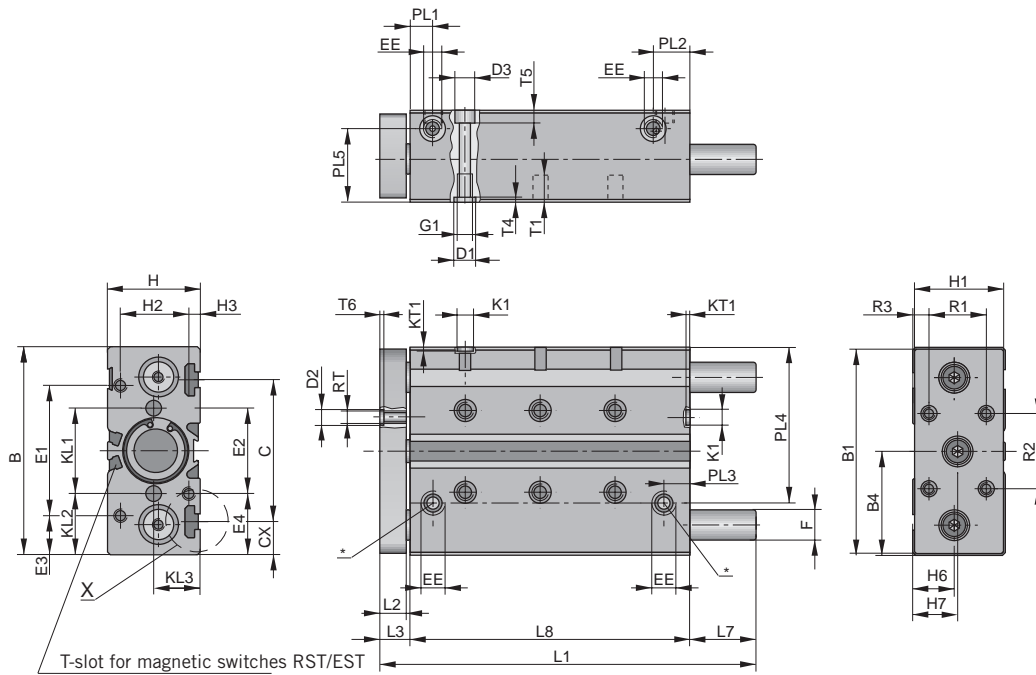

* Screw plugs

Dimensions Table (mm) – Series FZK(K) 6040 and 6050

Stroke	External Dimensions															
	L1		L2		L3		L7		L8		B		B1		B2	
	Ø40	Ø50	Ø40	Ø50	Ø40	Ø50	Ø40	Ø50	Ø40	Ø50	Ø40	Ø50	Ø40	Ø50	Ø40	Ø50
25	106	118	14	16	16	18	14	23	76	77	120	148	118	146	88	110
50	131	143					14	23	101	102						
80	179	194					32	44	131	132						
100	199	214					32	44	151	152						
125	244	259					52	64	176	177						
160	279	294					52	64	211	212						
200	319	334					52	64	251	252						

Stroke	External Dimensions															
	B3		B4		H		H1		H6		H7		F _{h6} (FZK)		F _{h8} (FZG)	
	Ø40	Ø50	Ø40	Ø50	Ø40	Ø50	Ø40	Ø50	Ø40	Ø50	Ø40	Ø50	Ø40	Ø50	Ø40	Ø50
25 to 200	16	19	60	74	54	64	52	62	24	29.5	26	29.7	16	20	20	25

Stroke	Mounting Dimensions															
	E ±0.1		E1 ±0.1		E2 ±0.1		E3		E4		A1 ±0.1		A2 ±0.1		A3	
	Ø40	Ø50	Ø40	Ø50	Ø40	Ø50	Ø40	Ø50	Ø40	Ø50	Ø40	Ø50	Ø40	Ø50	Ø40	Ø50
25	51	64	48	110	48	130	36	19	32.5	9	29	32	20	20	45	50
50													40	40		
80													40	40		
100													40	40		
125													40	40		
160													40	40		
200													40	40		

Stroke	Mounting Dimensions															
	A4 ±0.1		H2 ±0.1		H3		R1 ±0.1		R2 ±0.1		R3		RT		G1	
	Ø40	Ø50	Ø40	Ø50	Ø40	Ø50	Ø40	Ø50	Ø40	Ø50	Ø40	Ø50	Ø40	Ø50	Ø40	Ø50
25	–	–	42	50	6	7	30	40	50	60	16	12	M6	M8	M8	M8
50	–	–														
80	–	–														
100	80	80														
125	80	80														
160	120	120														
200	160	160														

Stroke	Mounting Dimensions											
	G2		T1		T2		T3		T5		ØD3	
	Ø40	Ø50	Ø40	Ø50	Ø40	Ø50	Ø40	Ø50	Ø40	Ø50	Ø40	Ø50
25 to 200	M8	M8	15	15	14	16	14	16	6.8	6.8	11	11

Stroke	Air Connection											
	EE		PL1		PL2		PL3		PL4		PL5	
	Ø40	Ø50	Ø40	Ø50	Ø40	Ø50	Ø40	Ø50	Ø40	Ø50	Ø40	Ø50
25 to 200	G1/8	G1/4	15.3	14	19.5	18.9	18.7	15	96	116.5	42	50.5

Stroke	T-Slot Mounting											
	C		C1		C2		C3		C4		CX	
	Ø40	Ø50	Ø40	Ø50	Ø40	Ø50	Ø40	Ø50	Ø40	Ø50	Ø40	Ø50
25 to 200	82	97	8.2	8.2	16.7	16.7	8	8	3	3	19	25.5

Stroke	Centring Bush Holes																	
	ØD1 ^{H7}		ØD2 ^{H7}		ØK1 ^{H7}		KL1		KL2		KL3		KT1		T4		T6	
	Ø40	Ø50	Ø40	Ø50	Ø40	Ø50	Ø40	Ø50	Ø40	Ø50	Ø40	Ø50	Ø40	Ø50	Ø40	Ø50	Ø40	Ø50
25 to 200	12	12	9	12	9	12	55	68	32.5	40	27	32	2.1	2.6	2.6	2.6	2.1	2.6

Applications

Lifting

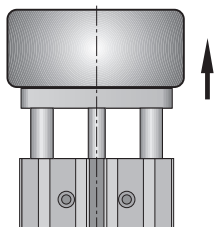

Pushing

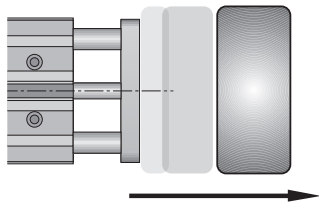

Stopping

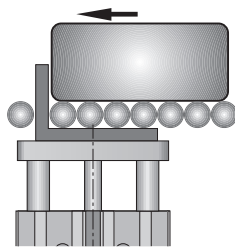

Stopping with Stop Bracket

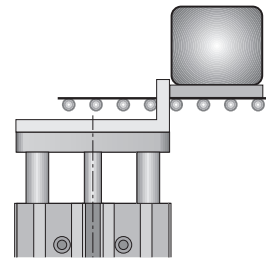

Mounting Possibilities

Flat mounting from above

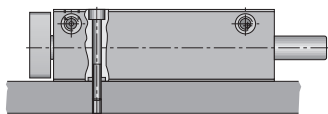

Flat mounting from below



Side mounting

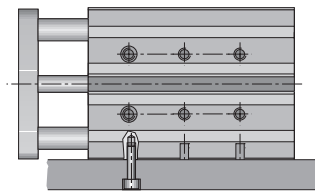



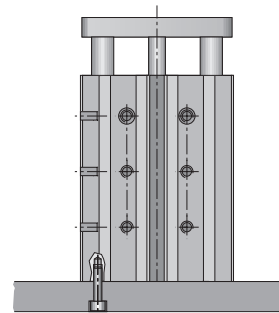

End face mounting

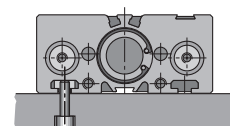

T-slot mounting

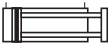

Order Instructions – Guided Cylinder FZK / FZG, Ø 20 – 50 mm

Cyl. Ø (mm)	Symbol	Stroke* (mm)	Order Instructions			
			with Sliding Guidance		with Ball Bearing Guidance	
			Type	Order-No.	Type	Order-No.
20		20	FZG6020/20	PA68240-0020	FZK6020/20	PA68250-0020
		25	FZG6020/25	PA68240-0025	FZK6020/25	PA68250-0025
		30	FZG6020/30	PA68240-0030	FZK6020/30	PA68250-0030
		40	FZG6020/40	PA68240-0040	FZK6020/40	PA68250-0040
		50	FZG6020/50	PA68240-0050	FZK6020/50	PA68250-0050
		80	FZG6020/80	PA68240-0080	FZK6020/80	PA68250-0080
		100	FZG6020/100	PA68240-0100	FZK6020/100	PA68250-0100
25		20	FZG6025/20	PA68260-0020	FZK6025/20	PA68270-0020
		25	FZG6025/25	PA68260-0025	FZK6025/25	PA68270-0025
		30	FZG6025/30	PA68260-0030	FZK6025/30	PA68270-0030
		40	FZG6025/40	PA68260-0040	FZK6025/40	PA68270-0040
		50	FZG6025/50	PA68260-0050	FZK6025/50	PA68270-0050
		80	FZG6025/80	PA68260-0080	FZK6025/80	PA68270-0080
		100	FZG6025/100	PA68260-0100	FZK6025/100	PA68270-0100
32		20	FZG6032/20	PA58640-0020	FZK6032/20	PA58650-0020
		25	FZG6032/25	PA58640-0025	FZK6032/25	PA58650-0025
		30	FZG6032/30	PA58640-0030	FZK6032/30	PA58650-0030
		40	FZG6032/40	PA58640-0040	FZK6032/40	PA58650-0040
		50	FZG6032/50	PA58640-0050	FZK6032/50	PA58650-0050
		80	FZG6032/80	PA58640-0080	FZK6032/80	PA58650-0080
		100	FZG6032/100	PA58640-0100	FZK6032/100	PA58650-0100
		125	FZG6032/125	PA58640-0125	FZK6032/125	PA58650-0125
		160	FZG6032/160	PA58640-0160	FZK6032/160	PA58650-0160
		200	FZG6032/200	PA58640-0200	FZK6032/200	PA58650-0200
40		25	FZG6040/25	PA59570-0025	FZK6040/25	PA59580-0025
		50	FZG6040/50	PA59570-0050	FZK6040/50	PA59580-0050
		80	FZG6040/80	PA59570-0080	FZK6040/80	PA59580-0080
		100	FZG6040/100	PA59570-0100	FZK6040/100	PA59580-0100
		125	FZG6040/125	PA59570-0125	FZK6040/125	PA59580-0125
		160	FZG6040/160	PA59570-0160	FZK6040/160	PA59580-0160
		200	FZG6040/200	PA59570-0200	FZK6040/200	PA59580-0200
50		25	FZG6050/25	PA60650-0025	FZK6050/25	PA60660-0025
		50	FZG6050/50	PA60650-0050	FZK6050/50	PA60660-0050
		80	FZG6050/80	PA60650-0080	FZK6050/80	PA60660-0080
		100	FZG6050/100	PA60650-0100	FZK6050/100	PA60660-0100
		125	FZG6050/125	PA60650-0125	FZK6050/125	PA60660-0125
		160	FZG6050/160	PA60650-0160	FZK6050/160	PA60660-0160
		200	FZG6050/200	PA60650-0200	FZK6050/200	PA60660-0200

*other strokes on request

Linear Guide, U-Form Ø 8-100 mm

for cylinders to
ISO 15552
(ISO 6431),
ISO6432

Series FEUG...

Version:
- with plain bearings

Supplied as follows:
Ø8 - 25mm:
for cylinders to ISO 6432
1 guide
1 mounting nut

Ø32 bis 100mm:
for cylinders to ISO 15552
(ISO 6431)

1 guide
4 mounting nuts

Characteristics

Characteristics	Symbol	Unit	Description
General Features			
Installation			In any position
Temperature range	T_{min}	°C	-20
	T_{max}	°C	+80
Material			
Guide body			Aluminium, anodized
Guide rods			Steel, corrosion-resistant
Guide bushes			Sintered bronze
Mounting plate			Aluminium, anodized
Piston rod mounting			Steel, corrosion-resistant
Weight (mass)	for cyl.		Ø8/10 Ø12/16 Ø20/25
With 100mm stroke	kg	0.20	0.38 0.68
Per further 100mm stroke	kg	0.05	0.08 0.13
Weight (mass)	for cyl.		Ø32 Ø40 Ø50 Ø63 Ø80 Ø100
With 100mm stroke	kg	1.32	1.98 3.35 4.60 8.30 10.85
Per further 100mm stroke	kg	0.18	0.32 0.50 0.50 0.77 0.77

Maximum working load in relation to overhang - FEUG version with plain bearings

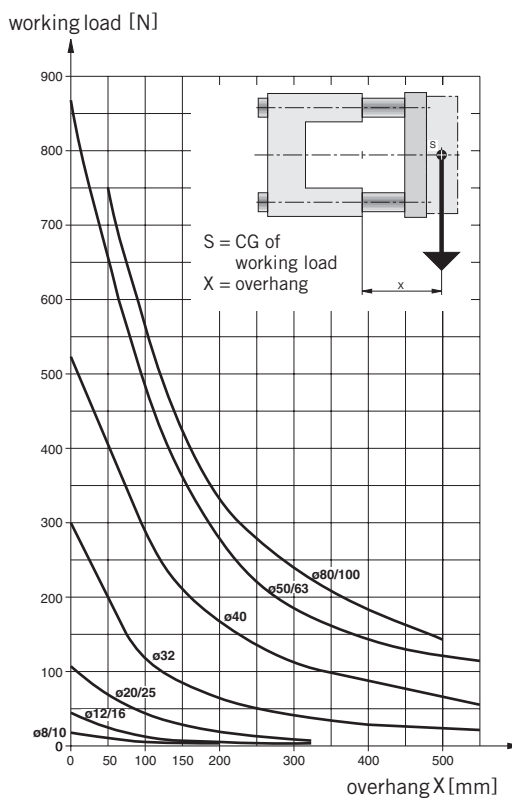

Deflection - FEUG version with plain bearings

Diagram 1 - Deflection with a working load of 10 N

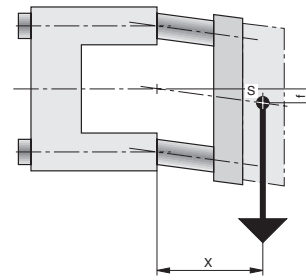
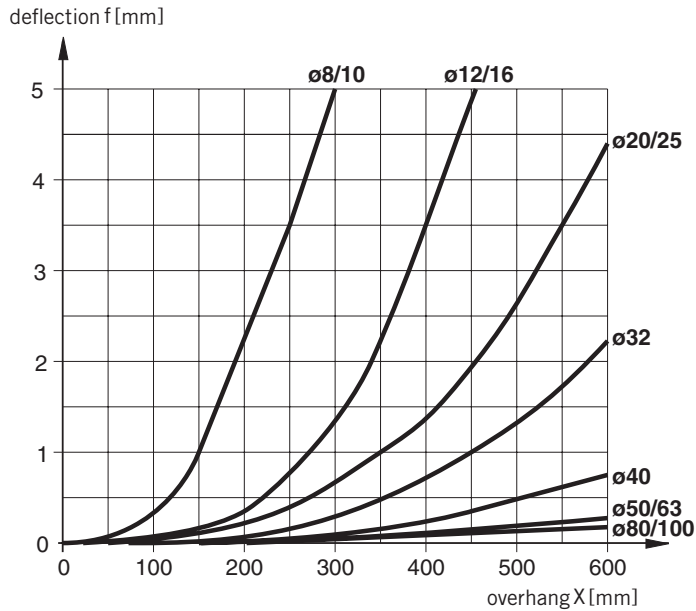

S = CG of working load
 X = overhang
 f = deflection

Deflection

The total deflection is the sum of the deflection under own weight (Diagram 2) and the deflection under load (Diagram 1). The deflection for every 10 N load is shown in Diagram 1.

Diagram 2 - Deflection under own weight

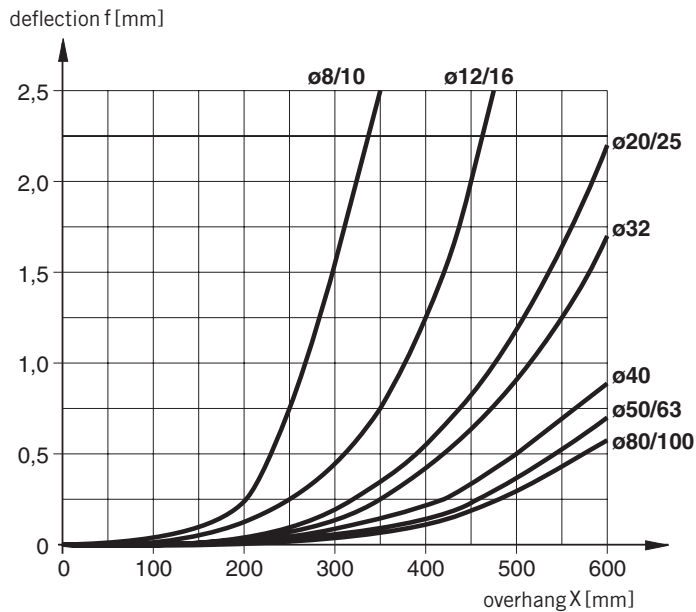

Dimensions of linear guides - for round cylinders $\varnothing 8$ to 25 mm

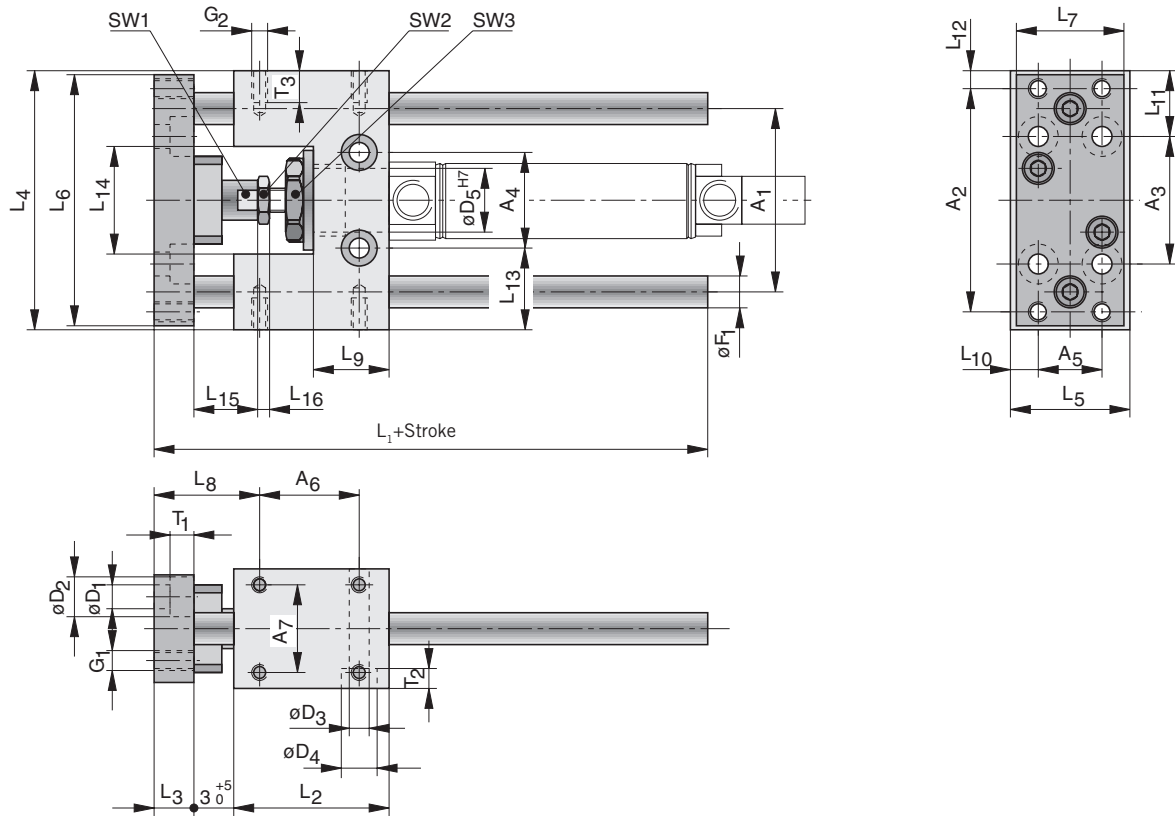

Dimensions table (mm) for linear guides - for round cylinders \varnothing 8 - 25 mm

Type	Cylinder diameter					
	8	10	12	16	20	25
A ₁	40	40	46	46	58	58
A ₂	44	44	54	54	68	68
A ₃	25	25	32	32	40	40
A ₄	24	24	24	24	38	38
A ₅	16	16	16	16	20	20
A ₆	19	19	25	25	32.5	32.5
A ₇	19	19	22	22	23	23
ØD ₁	4.5	4.5	4.5	4.5	5.5	5.5
ØD ₂	7.5	7.5	8	8	10	10
ØD ₃	4.5	4.5	5.5	5.5	6.6	6.6
ØD ₄	–	–	–	–	11	11
ØD ₅ ^{H7}	12	12	16	16	22	22
ØF ₁	6	6	8	8	10	10
G ₁	M4	M4	M4	M4	M5	M5
G ₂	M4	M4	M4	M4	M6	M6
L ₁ +stroke	60	60	69	69	85	85
L ₂	35	35	39	39	55	55
L ₃	10	10	10	10	12	12
L ₄	56	56	65	65	79	79
L ₅	26	26	30	30	34	34
L ₆	54	54	63	63	76	76
L ₇	25	25	27	27	32	32
L ₈	21 ⁺⁵ ₀	21 ⁺⁵ ₀	19.5 ⁺⁵ ₀	19.5 ⁺⁵ ₀	24 ⁺⁵ ₀	24
L ₉	17	17	19	19	25	25
L ₁₀	5.5	5.5	7.5	7.5	7	7
L ₁₁	16	16	16.5	16.5	19.5	19.5
L ₁₂	6	6	5.5	5.5	5.5	5.5
L ₁₃	16	16	20.5	20.5	20.5	20.5
L ₁₄	24	24	27	27	37	37
L ₁₅	19	19	16	16	29	23
L ₁₆	2.2	2.2	3.2	3.2	4	6
SW1	9	9	9	9	13	13
SW2	–	7*	10*	11*	13*	17*
SW3	15	15	19	19	27	27
T ₁	4.6	4.6	4.6	4.6	5.7	5.7
T ₂	–	–	–	–	7	7
T ₃	8	8	8	8	14	14

* Nut sizes correspond to the sizes of the counternuts on the piston rods

Dimensions table (mm) for linear guides - for standard cylinders ø 32 - 100 mm

Type	Cylinder diameter					
	32	40	50	63	80	100
A ₁	74	87	104	119	148	172
A ₂	32.5	38	46.5	56.5	72	89
A ₃	78	84	100	105	130	150
A ₄	61	69	85	100	130	150
A ₅	25	29	35	42.5	52.5	65
ØD ₁	6.6	6.6	9	9	11	11
ØD ₂	11	11	15	15	18	18
ØD ₃	30	35	40	45	45	55
ØF ₁	12	16	20	20	25	25
G ₁	M6	M6	M8	M8	M10	M10
L ₁ +stroke	133	149	175	190	238	249
L ₂	72	84	100	115	162	167
L ₃	12	12	15	15	20	20
L ₄	97	115	137	152	189	213
L ₅	50	58	70	85	105	130
L ₆	90	110	130	145	180	200
L ₇	45	54	63	80	100	120
L ₈	60.5 ⁺⁵ ₀	63.5 ⁺⁵ ₀	76 ⁺⁵ ₀	76 ⁺⁵ ₀	93 ⁺⁶ ₀	95.5 ⁺⁶ ₀
L ₉	35 ⁺⁵ ₀	41 ⁺⁵ ₀	48 ⁺⁵ ₀	48 ⁺⁵ ₀	56 ⁺⁶ ₀	56 ⁺⁶ ₀
L ₁₀	8.75	10.0	11.75	14.25	16.5	20.5
L ₁₁	9.5	15.5	18.5	23.5	29.5	31.5
L ₁₂	32.25	38.5	45.25	47.75	58.5	62
L ₁₃	18	23	26	26	29.5	31.5
L ₁₄	44	51	60	75	112	112
L ₁₅	50.2	58.2	70.2	85.2	105.4	130.4
L ₁₆	30	36	42	42	49	49
L ₁₇	6	7	8	8	10	10
SW1	13	15	22	22	27	27
SW2	17	19	24	24	30	30
T ₁	6.5	6.5	9	9	11	11
T ₂	10	10	13	13	16	16

Order Instructions – Linear Guide FEUG..., Ø 8 – 40 mm

for Cyl. Ø (mm)	Stroke (mm)	Order Instructions	
		Typ	Bestell-Nr.
8, 10	25	FEUG8-10/25	PD38013-0025
	50	FEUG8-10/50	PD38013-0050
	100	FEUG8-10/100	PD38013-0100
12, 16	50	FEUG12-16/50	PD38014-0050
	100	FEUG12-16/100	PD38014-0100
	200	FEUG12-16/200	PD38014-0200
20	50	FEUG20/50	PD38015-0050
	100	FEUG20/100	PD38015-0100
	160	FEUG20/160	PD38015-0160
	200	FEUG20/200	PD38015-0200
	250	FEUG20/250	PD38015-0250
	400	FEUG20/400	PD38015-0400
25	50	FEUG25/50	PD38016-0050
	100	FEUG25/100	PD38016-0100
	160	FEUG25/160	PD38016-0160
	200	FEUG25/200	PD38016-0200
	250	FEUG25/250	PD38016-0250
	400	FEUG25/400	PD38016-0400
32	50	FEUG32/50	PD38017-0050
	100	FEUG32/100	PD38017-0100
	160	FEUG32/160	PD38017-0160
	200	FEUG32/200	PD38017-0200
	250	FEUG32/250	PD38017-0250
	320	FEUG32/320	PD38017-0320
40	50	FEUG40/50	PD38018-0050
	100	FEUG40/100	PD38018-0100
	160	FEUG40/160	PD38018-0160
	200	FEUG40/200	PD38018-0200
	250	FEUG40/250	PD38018-0250
	320	FEUG40/320	PD38018-0320

Order Instructions – Linear Guide FEUG..., Ø 50 – 100 mm

for Cyl. Ø (mm)	Stroke (mm)	Order Instructions	
		Typ	Bestell-Nr.
50	50	FEUG50/50	PD38019-0050
	100	FEUG50/100	PD38019-0100
	160	FEUG50/160	PD38019-0160
	200	FEUG50/200	PD38019-0200
	250	FEUG50/250	PD38019-0250
	320	FEUG50/320	PD38019-0320
63	50	FEUG63/50	PD38020-0050
	100	FEUG63/100	PD38020-0100
	160	FEUG63/160	PD38020-0160
	200	FEUG63/200	PD38020-0200
	250	FEUG63/250	PD38020-0250
	320	FEUG63/320	PD38020-0320
80	50	FEUG80/50	PD38021-0050
	100	FEUG80/100	PD38021-0100
	160	FEUG80/160	PD38021-0160
	200	FEUG80/200	PD38021-0200
	250	FEUG80/250	PD38021-0250
	320	FEUG80/320	PD38021-0320
100	50	FEUG100/50	PD38022-0050
	100	FEUG100/100	PD38022-0100
	160	FEUG100/160	PD38022-0160
	200	FEUG100/200	PD38022-0200
	250	FEUG100/250	PD38022-0250
	320	FEUG100/320	PD38022-0320

Characteristics

Characteristics	Symbol	Unit	Description				
General Features							
Installation			In any position				
Temperature range	T_{min}	°C	-20				
	T_{max}	°C	+80				
Material							
Guide body	Aluminium, anodized						
Guide rods	Steel, corrosion-resistant for FEHG version Steel, hardened for FEHK version						
Guide bushes	Sintered bronze for FEHG version Linear ball bearings for FEHK version						
Mounting plate	Aluminium, anodized						
Piston rod mounting	Steel, corrosion-resistant						
Weight (mass)	for Cyl.	Ø32	Ø40	Ø50	Ø63	Ø80	Ø100
With 100 mm stroke	kg	1.42	2.25	3.80	5.05	9.18	11.80
Per further 100 mm stroke	kg	0.18	0.28	0.55	0.55	0.77	0.77

Linear Guide, H-Form Ø 32-100 mm

for cylinders to
ISO 15552
(ISO6431)
32-100 mm

Series FEH...

Version:

– with plain bearings

FEHG...

– with ball bearings

FEHK...

Supplied as follows:

Ø32 to 100mm:
für Zylinder nach ISO 15552
(ISO 6431)

1 guide

4 mounting nuts

Maximum working load in relation to overhang - FEHG version with plain bearings

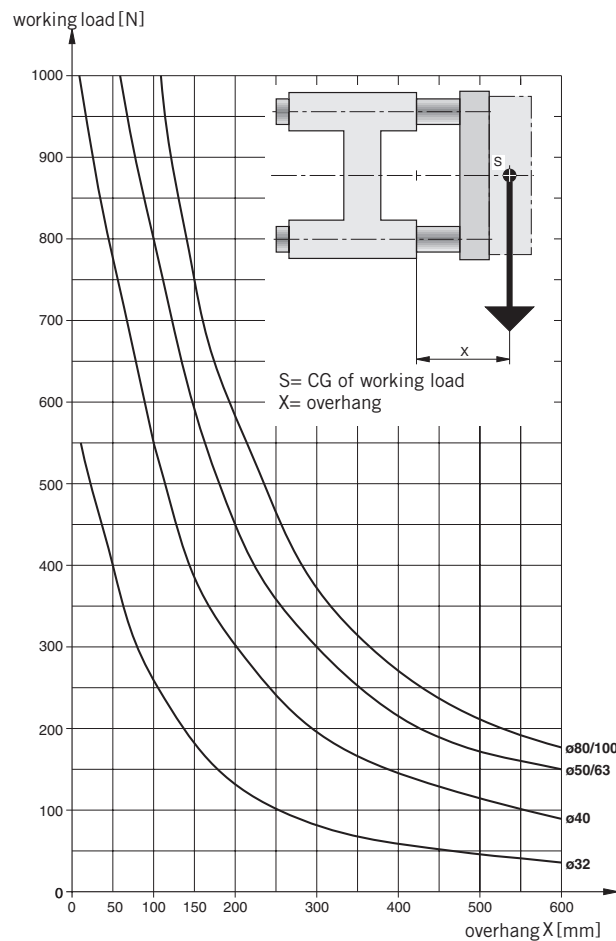

For short strokes, the working load figures obtained from the diagrams must be multiplied by a correction factor (k) (see Diagram). In the working load curves for overhangs up to 60 mm these short stroke corrections are already included. In the case of impact loads, the maximum permissible working load must be halved..

Factor 1
for normal applications

Factor 2
for impact loads

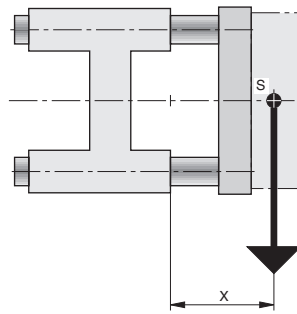

S= CG of working load
X= overhang

**Maximum working load in relation to overhang
- FEHK version with ball bearings**

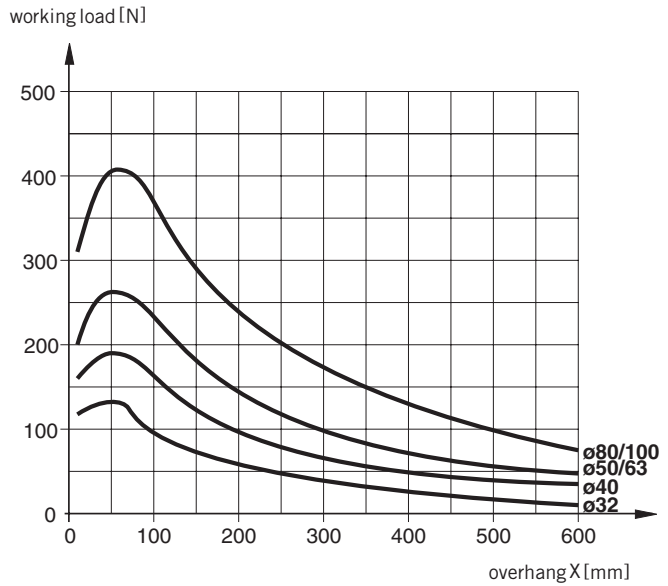

**Reduction of working load with short strokes
- FEHK version with ball bearings**

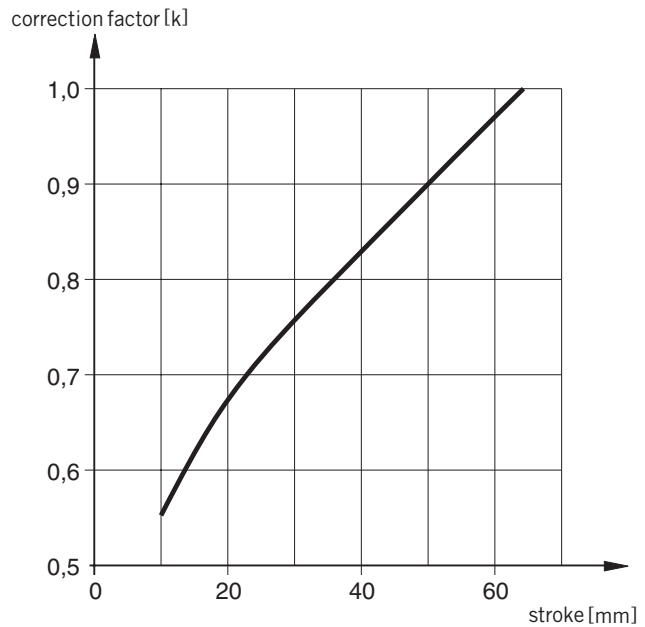

Deflection - FEHG version with plain bearings and FEHK version with ball bearings

Diagram 1 - Deflection with a working load of 10N

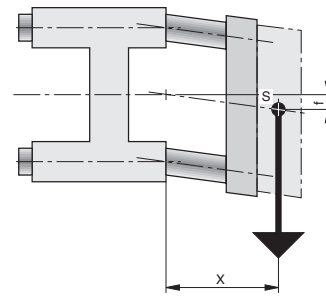
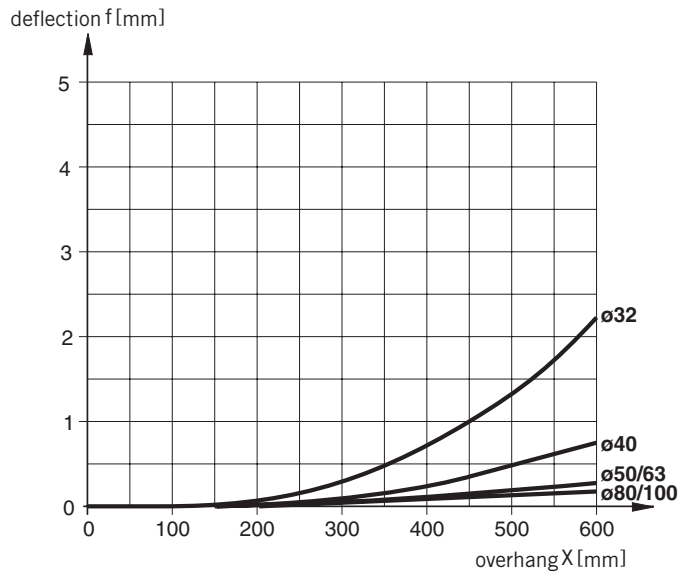

Deflection

The total deflection is the sum of the deflection under own weight (Diagram 2) and the deflection under load (Diagram 1).

The deflection for every 10 N load is shown in Diagram 1.

S = CG of working load
 X = overhang
 f = deflection

Diagram 2 - Deflection under own weight

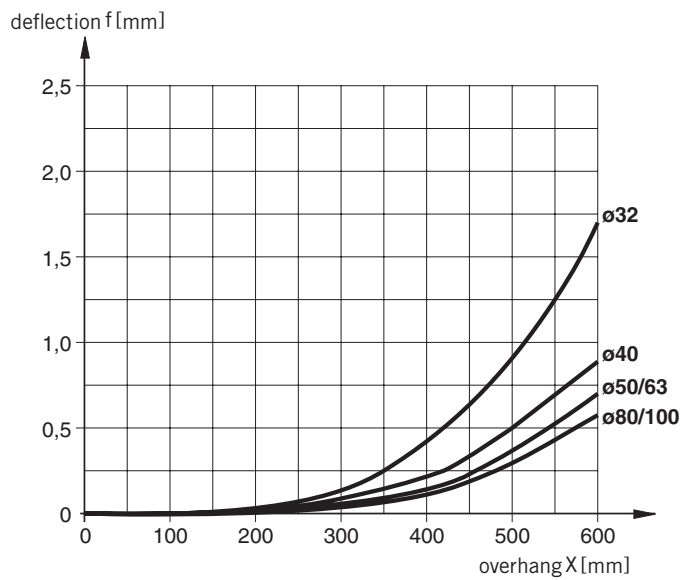

Dimensions – Linear Guide Type FEHG ..., FEHK..., $\varnothing 32 - 100$ mm

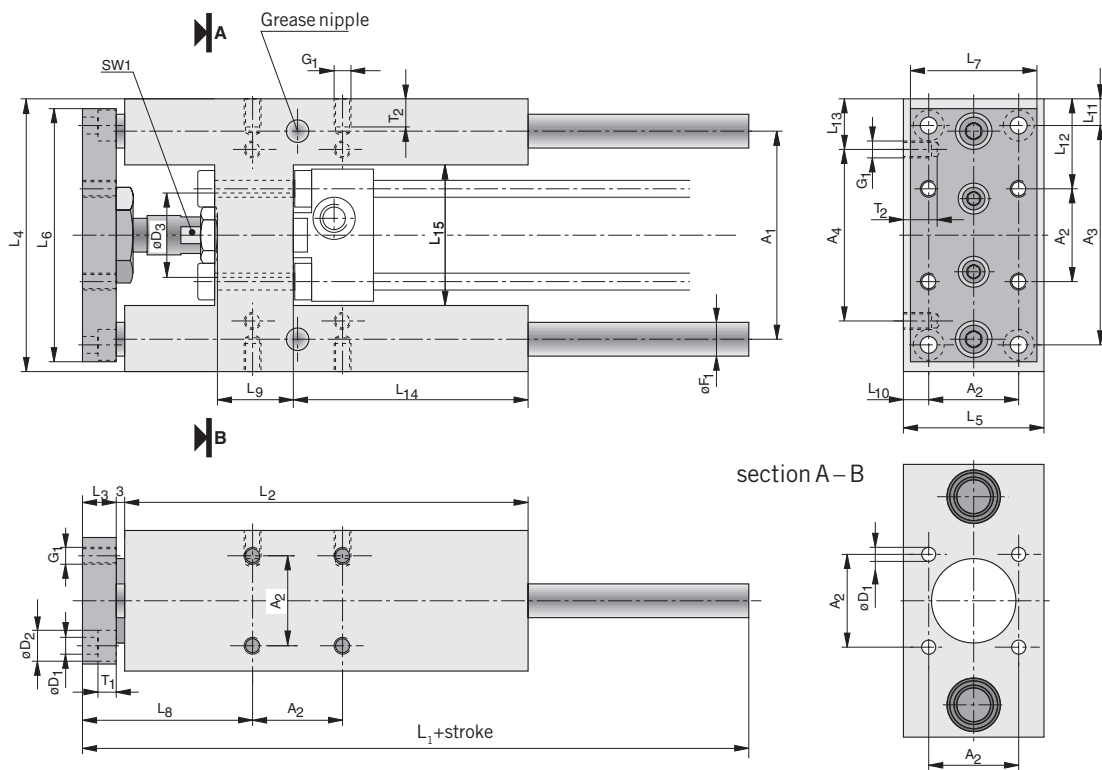

Dimension Table (mm) – Linear Guide Type FEHG., FEHK., Ø 32 – 100 mm

Type	Cylinder diameter					
	32	40	50	63	80	100
A ₁	74	87	104	119	148	172
A ₂	32.5	38	46.5	56.5	72	89
A ₃	78	84	100	105	130	150
A ₄	61	69	85	100	130	150
ØD ₁	6.6	6.6	9	9	11	11
ØD ₂	11	11	15	15	18	18
ØD ₃	30	35	40	45	45	55
ØF ₁	14 (12*)	18 (16*)	22 (20*)	22 (20*)	25	25
G ₁	M6	M6	M8	M8	M10	M10
L ₁ +Hub	177	192	237	237	280	280
L ₂	125	140	150	182	215	220
L ₃	12	12	15	15	20	20
L ₄	97	115	137	152	189	213
L ₅	50	58	70	85	105	130
L ₆	90	110	130	145	180	200
L ₇	45	54	63	80	100	120
L ₈	59.70 ⁺⁵ ₀	63 ⁺⁵ ₀	70.2 ⁺¹⁰ ₀	73.5 ⁺¹⁰ ₀	89 ⁺¹⁰ ₀	90.5 ⁺¹⁰ ₀
L ₉	28	33	40	40	50	50
L ₁₀	8.75	10.0	11.75	14.25	16.5	20.5
L ₁₁	9.5	15.5	18.5	23.5	29.5	31.5
L ₁₂	32.25	38.5	45.25	47.75	58.5	62
L ₁₃	18	23	26	26	29.5	31.5
L ₁₄	65	69	65	97	112	112
L ₁₅	50.5	58.5	70.5	85.5	105.4	130.4
SW1	13	15	22	22	27	27
SW2	–	–	–	–	30	30
T ₁	6.5	6.5	9	9	11	11
T ₂	10	10	13	13	16	16

* (FEHK version with ball bearings)

Order Instructions – Linear Guide Type FEHG, FEHK

for Cyl.Ø (mm)	Stroke (mm)	Order Instructions for plain bearing version		Order Instructions for ball bearing version	
		Type	Order-No.	Type	Order-No.
32	50	FEHG32/50	PD38001-0050	FEHK32/50	PD38007-0050
	100	FEHG32/100	PD38001-0100	FEHK32/100	PD38007-0100
	160	FEHG32/160	PD38001-0160	FEHK32/160	PD38007-0160
	200	FEHG32/200	PD38001-0200	FEHK32/200	PD38007-0200
	250	FEHG32/250	PD38001-0250	FEHK32/250	PD38007-0250
	320	FEHG32/320	PD38001-0320	FEHK32/320	PD38007-0320
40	50	FEHG40/50	PD38002-0050	FEHK40/50	PD38008-0050
	100	FEHG40/100	PD38002-0100	FEHK40/100	PD38008-0100
	160	FEHG40/160	PD38002-0160	FEHK40/160	PD38008-0160
	200	FEHG40/200	PD38002-0200	FEHK40/200	PD38008-0200
	250	FEHG40/250	PD38002-0250	FEHK40/250	PD38008-0250
	320	FEHG40/320	PD38002-0320	FEHK40/320	PD38008-0320
50	50	FEHG50/50	PD38003-0050	FEHK50/50	PD38009-0050
	100	FEHG50/100	PD38003-0100	FEHK50/100	PD38009-0100
	160	FEHG50/160	PD38003-0160	FEHK50/160	PD38009-0160
	200	FEHG50/200	PD38003-0200	FEHK50/200	PD38009-0200
	250	FEHG50/250	PD38003-0250	FEHK50/250	PD38009-0250
	320	FEHG50/320	PD38003-0320	FEHK50/320	PD38009-0320
63	50	FEHG63/50	PD38004-0050	FEHK63/50	PD38010-0050
	100	FEHG63/100	PD38004-0100	FEHK63/100	PD38010-0100
	160	FEHG63/160	PD38004-0160	FEHK63/160	PD38010-0160
	200	FEHG63/200	PD38004-0200	FEHK63/200	PD38010-0200
	250	FEHG63/250	PD38004-0250	FEHK63/250	PD38010-0250
	320	FEHG63/320	PD38004-0320	FEHK63/320	PD38010-0320
80	50	FEHG80/50	PD38005-0050	FEHK80/50	PD38011-0050
	100	FEHG80/100	PD38005-0100	FEHK80/100	PD38011-0100
	160	FEHG80/160	PD38005-0160	FEHK80/160	PD38011-0160
	200	FEHG80/200	PD38005-0200	FEHK80/200	PD38011-0200
	250	FEHG80/250	PD38005-0250	FEHK80/250	PD38011-0250
	320	FEHG80/320	PD38005-0320	FEHK80/320	PD38011-0320
100	50	FEHG100/50	PD38006-0050	FEHK100/50	PD38012-0050
	100	FEHG100/100	PD38006-0100	FEHK100/100	PD38012-0100
	160	FEHG100/160	PD38006-0160	FEHK100/160	PD38012-0160
	200	FEHG100/200	PD38006-0200	FEHK100/200	PD38012-0200
	250	FEHG100/250	PD38006-0250	FEHK100/250	PD38012-0250
	320	FEHG100/320	PD38006-0320	FEHK100/320	PD38012-0320