

Injection lubricator system

*Series oilfit
G1/4 to G1*

– Injection lubricator elements and combinations for individual and group activation

Overview

Description	Page		
	Characteristics	Dimensions	Order instructions Type overview
Single-point injection lubricator combination, type LUBI, with an internal pressurized oil supply to the integrated flow sensor for ease of installation in pipelines.	168, 169, 172	173	177
Single-point injection lubricator combination, type LUBE, with compressed oil inlet at lubricator element; for direct installation in pipelines	168, 169, 172	173	177
Single-point injection lubricator combination, type LB, with oil feed via external pneumatic signal	168, 169	174	177
Three-point injection lubricator combination, type LB, oil feed via external pneumatic signal	168, 169	174	177
Three-point injection lubricator combination, type LB, with separate oil feed via three external pneumatic signals	168, 169,	174	177
Single-point injection lubricator element, type L10i, Single-point injection lubricator element, type L10i, with internal pressurized oil supply to the integrated flow sensor; without reservoir	170, 171	175	177
Single-point injection lubricator element, type L10e, with external compressed oil outlet; without reservoir	170, 171	175	177
Single-point injection lubricator element, type L, with air inlet at the top and bottom; without reservoir	170, 171	176	177
Three-point injection lubricator element, type L, with air inlet at the top and bottom for group activation (all three compressed oil outlets feed simultaneously when an air pulse is generated)	170, 171	176	177
Three-point injection lubricator element, type L, with three lateral air supply points (only the appropriate compressed oil outlet feeds when an air pulse is generated)	170, 171	176	177
Single-point injection lubricator element, type LUI, with internal compressed oil outlet in fitted converter; for direct installation in pipelines; without reservoir	168, 169	175	177
Accessories, converter, oil reservoir, intersection elements, injection inlets, oil reservoir, atomizer	172, 178–182	178–182	183



Injection lubricator system

Series oilfit
G1/4 to G1

– Injection lubricator elements and combinations for individual and group activation

Characteristics



Pressures quoted as gauge pressure

Characteristics	Symbol	Unit	Injection lubricator combinations				
System			Single-point injection lubricator. Automatic oil feed when connected pneumatic tool is switched on.				
Type			LUBI				
Material							
– Housing			Diecast aluminum				
– Reservoir			Polyester resin (PETP)				
– Actuating plunger			Polyamide transparent				
– Oil connection			Brass				
– Sealings			NBR				
Port size			G1/4	G3/8	G1/2	G3/4	G1
Port size control air			–	–	–	–	–
Port size lubricant							
– Inlet			– (Oil reservoir)				
– Outlet			Coupling for tube Ø 2.5/1.5, coaxially in airline				
Mounting			2 M6 screws are included in delivery				
Installation			Horizontal, reservoir on top				
Medium and ambient temperatures	T_{min} T_{max}	°C °C	-20 +50				
Control medium			Filtered compressed air				
Lubricant			Mineral oil to DIN 1524 and DIN 51525				
Viscosity		mm ² /s	20–765				
Weight (mass)		kg	0.65	0.65	0.65	0.75	0.80
Operating pressure range of air	p_{min} p_{max}	bar bar	3 10				
Operating pressure range of lubricant			Inlet: without pressure from fitted reservoir (gravity feed) Outlet: 0–250 bar depending on operating pressure and oil injection conditions				
Recommended flow ¹⁾	Q_n	l/min m ³ /h	550 33	850 51	1900 114	3500 210	5000 300
Own air usage ²⁾	Q_n	m ³ /h	0.36				
Minimum flow at 6 bar	Q_{min}	m ³ /h	9				
Reservoir capacity		cm ³	250				
Oil feed per stroke		mm ³	3–30 adjustable, factory adjustment 30 mm ³ /stroke				
Optional extension kits			Up to max. 10 lubrication points by fitting of elements L11, L31, or L33				

¹⁾ at 6 bar and 25 m/s

²⁾ at 6 bar and Ø 0.3 mm and $Q_n > Q_{min}$ (i.e. only when there is flow)

Single-point injection lubricator. Automatic oil feed when connected pneumatic tool is switched on.					Single-point lubricator with 1 control air inlet, oil feed actuated by external pneumatic signal.		Three-point lubricator with 1 control air inlet (combined actuation), oil feed actuated by external pneumatic signal.		Three-point lubricator with 3 separate control air inlets (individual actuation), oil feed actuated by three external pneumatic signals.		Single-point injection lubricator with integrated flow sensor, automatic oil feed when connected pneumatic tool is switched on.				
LUBE					LB11		LB31		LB33		LUI				
Diecast aluminum					Diecast zinc						Diecast aluminum				
Polyester resin (PETP)					Polyester resin (PETP)						Polyester resin (PETP)				
Polyamide, transparent					Polyamide, transparent						Polyamide, transparent				
Brass					Brass						Brass				
NBR					NBR						NBR				
G1/4 G3/8 G1/2 G3/4 G1					-		-		-		G1/4 G3/8 G1/2 G3/4 G1				
-					G1/8		G1/8		G1/8		-				
-					-		-		-		-				
- (Oil reservoir)					- (Oil reservoir)		- (Oil reservoir)		- (Oil reservoir)		G1/8				
M6 x 0.75					M6 x 0.75		M6 x 0.75		M6 x 0.75		Coupling for tube Ø 2 .5/1.5, coaxially in airline				
In-line mounting (2 M6 screws are included in delivery)					In-line mounting (2 M6 screws are included in delivery)						In-line mounting (2 M6 screws are included in delivery)				
Horizontal, reservoir on top					Horizontal, reservoir on top						Horizontal (flow direction of air flow sensor)				
-20 +50					-20 +50						-20 +50				
Filtered compressed air					Filtered compressed air						Filtered compressed air				
Mineral oil to DIN 1524 and DIN 51525					Mineral oil to DIN 1524 and DIN 51525						Mineral oil to DIN 1524 and DIN 51525				
20-765					20-765						20-765				
0.65 0.65 0.65 0.75 0.80					0.45		0.65		0.65		0.45 0.45 0.45 0.50 0.50				
3 10					3 10						3 10				
Inlet: without pressure from fitted reservoir (gravity feed) Outlet: 0-250 bar depending on operating pressure and oil injection conditions					Inlet: without pressure from fitted reservoir (gravity feed) Outlet: 0-250 bar depending on operating pressure and oil injection conditions						Inlet: without pressure from fitted reservoir (gravity feed) Outlet: 0-250 bar depending on operating pressure and oil injection conditions				
550 850 1900 3500 5000 33 51 114 210 300					-		-		-		550 850 1900 3500 5000 33 51 114 210 300				
0.36					-						0.36				
9					-		-		-		9				
250					250						250				
3-30 adjustable, factory adjustment 30 mm ³ /stroke					3-30 adjustable, factory adjustment 30 mm ³ /stroke		30 mm ³ /stroke				3-30 adjustable, factory adjustment 30 mm ³ /stroke				
Up to max. 10 lubrication points by fitting of elements L11, L31, or L33					Up to max. 10 lubrication points by fitting of elements L11, L31, or L33						Up to max. 10 lubrication points by fitting of elements L11, L31, or L33				

Injection lubricator system

Series oilfit
G1/4 to G1

– Injection lubricator elements and combinations for individual and group activation

Characteristics



Pressures quoted as gauge pressure

Characteristics	Symbol	Unit	Injection lubricator elements	
System			Single-point injection lubricator element with internal pressure oil outlet into the flow sensor	Single-point injection lubricator element with external pressure supply, oil feed actuated by flow sensor signal, for installation with a flow sensor
Type			L10 i	L10 e
Material				
– Housing			Diecast aluminum	
– Reservoir			Polyester resin (PETP)	
– Actuating plunger			Polyamide, transparent	
– Oil connection			Brass	
– Sealings			NBR	
Port size			–	–
Port size control air			–	–
Port size lubricant				
– Inlet			G1/8	G1/8
– Outlet			Into the flow sensor	M6 x 0.75
Mounting			2 M6 screws, with coupling kit either directly on oil reservoir or on other lubricator elements	
Installation			Horizontal (oil channel S → S) see drawing	
Medium and ambient temperatures	T_{\min} T_{\max}	°C °C	-20 +80	-20 +80
Control medium			Filtered compressed air	Filtered compressed air
Lubricant			Mineral oil to DIN 1524 and DIN 51525	
Viscosity		mm ² /s	20–765	20–765
Weight (mass)		kg	0.25	0.25
Operating pressure range of air	p_{\min} p_{\max}	bar bar	3 10	3 10
Operating pressure range of lubricant			Inlet: gravity feed or pressure feed (max. 3 bar) Outlet: 0–250 bar depending on operating pressure and oil injection conditions	
Recommended flow ¹⁾	Q_n	l/min m ³ /h	–	–
Own air usage ²⁾	Q_n	m ³ /h	–	–
Minimum flow at 6 bar	Q_{\min}	m ³ /h	–	–
Reservoir capacity		cm ³	–	–
Oil feed per stroke		mm ³	3–30 adjustable factory adjustment 30 mm ³ /stroke	

¹⁾ at 6 bar and 25 m/s

²⁾ at 6 bar and \varnothing 0.3 mm and $Q_n > Q_{\min}$ (i.e. only when there is flow)

Single-point injection lubricator element with air connection on top and bottom side. Oil feed through external pneumatic signal	Three-point injection lubricator element with air connection on top and bottom side for combined actuation (air signal simultaneously actuates all three pressure oil outlets)	Three-point injection lubricator element with air connection on top and bottom side for combined actuation, with three lateral air connections (each air signal actuates only its corresponding pressure oil outlet)	Flow sensor for converting air flow into a digital air signal – to injection lubricator elements L10i and L10e				
L11	L31	L33	U-08	U-10	U-15	U-20	U-25
Diecast aluminum							
Polyester resin (PETP)							
Polyamide, transparent							
Brass							
NBR							
–	–	–					
G1/8	G1/8	G1/8	G1/4	G3/8	G1/2	G3/4	G1
G1/8	G1/8	G1/8	–				
M6 x 0.75	M6 x 0.75	M6 x 0.75	Tube nipple for tube Ø 2.5/1.5, coaxially in airline				
2 M6 screws, with coupling kit either directly on oil reservoir or on other lubricator elements	2 M6 screws, with coupling kit either directly on oil reservoir or on other lubricator elements	2 M6 screws, with coupling kit either directly on oil reservoir or on other lubricator elements	In-line mounting, to element L10i and L10e (2 M6 screws included in delivery)				
Horizontal (oil channel S → S) see drawing	Horizontal (oil channel S → S) see drawing	Horizontal (oil channel S → S) see drawing	Horizontal				
-20 +80	-20 +80	-20 +80	-20 +80				
Filtered compressed air	Filtered compressed air	Filtered compressed air	Filtered compressed air				
Mineral oil to DIN 1524 and DIN 51525	Mineral oil to DIN 1524 and DIN 51525	Mineral oil to DIN 1524 and DIN 51525	–				
20–765	20–765	20–765	–				
0.40	0.40	0.40	0.20	0.20	0.20	0.25	0.30
3 10	3 10	3 10	3 10				
Inlet: gravity feed or pressure feed (max. 3 bar) Outlet: 0–250 bar depending on operating pressure and oil injection conditions			–				
–	–	–	550 33	850 51	1900 114	3500 210	5000 300
–	–	–	0.36				
–	–	–	9				
–	–	–	–				
3–30 adjustable factory adjustment 30 mm ³ /stroke	3–30 adjustable factory adjustment 30 mm ³ /stroke	3–30 adjustable factory adjustment 30 mm ³ /stroke	–				

Injection lubricator system

Series oilfit

Flow characteristics

Air flow sensor and injection lubricator combination with air flow sensor
Type: LUBI, LUBE, LUI- U

Port size G1/4

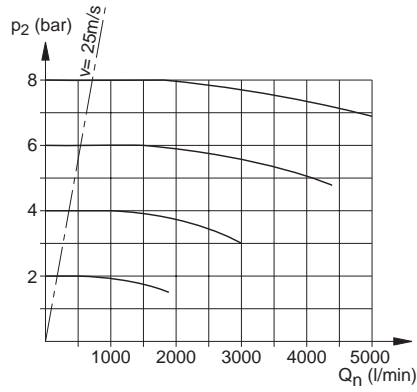

Port size G3/8

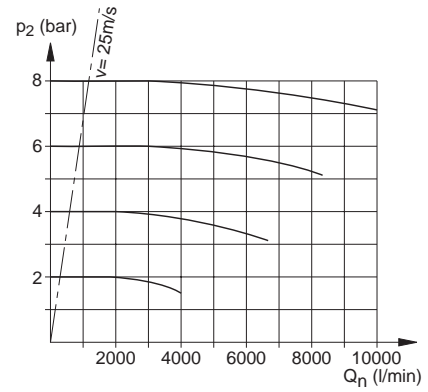

Port size G1/2, G3/4, G1

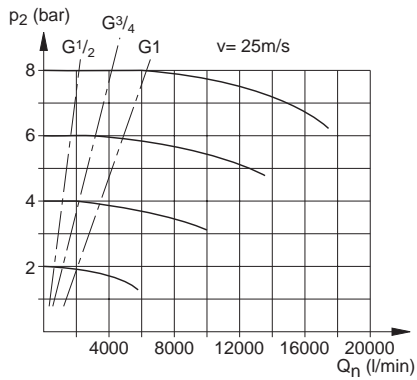

Minimum flow

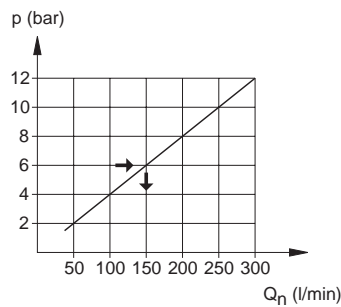

Adjustment of oil feed

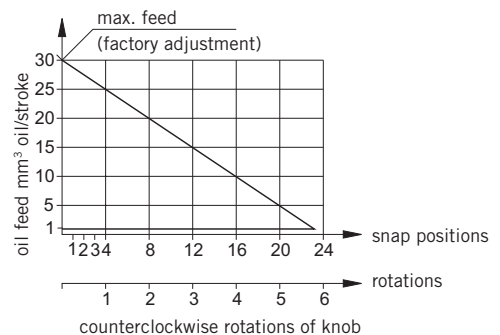

Type: LUBI-08, 10, 15, 20, 25

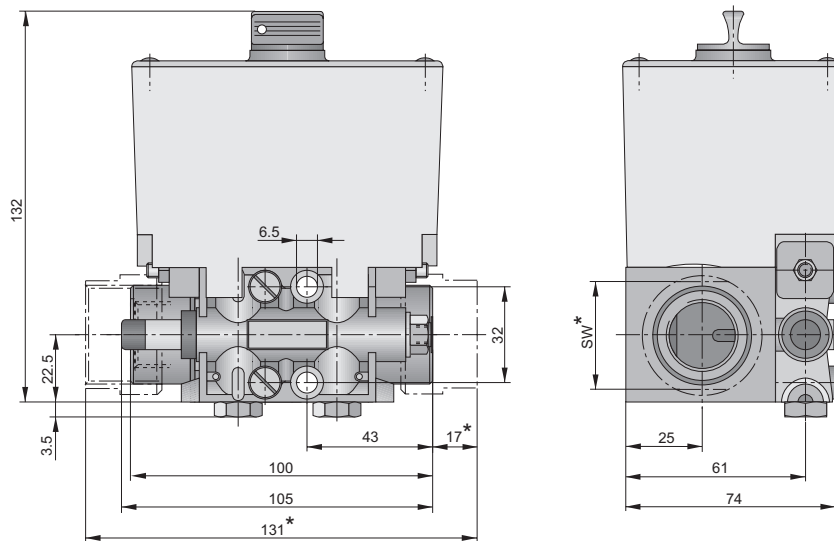

* Only for LUBI-20 SW=36
LUBI-25 SW=41

Injection lubricator system

Series oilfit

Dimensions

Injection lubricator combination
Type: LUBI-..

This combination, comprising an oil reservoir, flow sensor and single-point lubricator element, is used to lubricate individually operated compressed air tools. The pressure oil connection is inside the air outlet port of the air flow sensor.

Type: LUBE-08, 10, 15, 20, 25

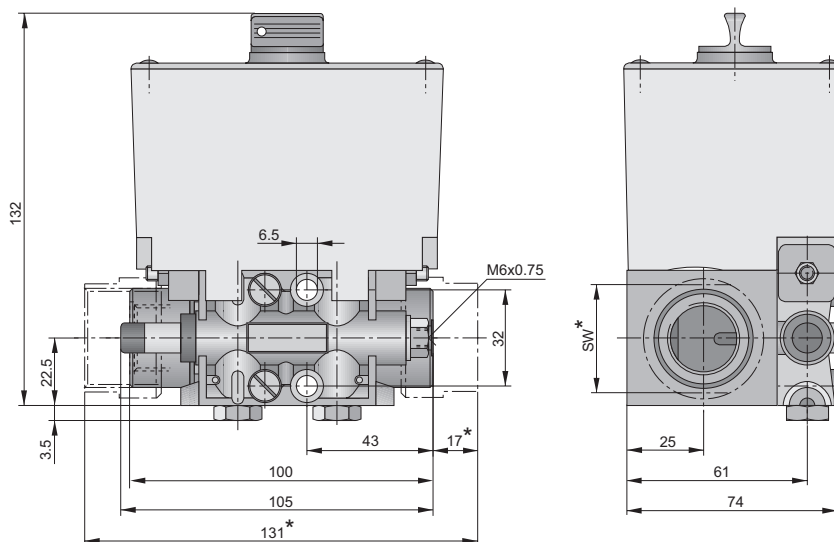

* Only for LUBE-20 SW=36
LUBE-25 SW=41

Injection lubricator combination
Type: LUBE-..

This combination, comprising an oil reservoir, flow sensor and single-point lubricator element, is used to lubricate individually operated compressed air tools. The pressure oil connection is outside of the flow sensor, directly on the outlet of the lubricator element.

For order instructions see page 183, for characteristics see page 168–172, for accessories see page 178–183

Dimensions in mm



Injection lubricator system

Series oilfit

Dimensions

Injection lubricator combination Type: LB11

This combination, comprising an oil reservoir and single-point lubricator element, is used to lubricate compressed air cylinders, synchronized feed devices or compressed air tools.

Type: LB11

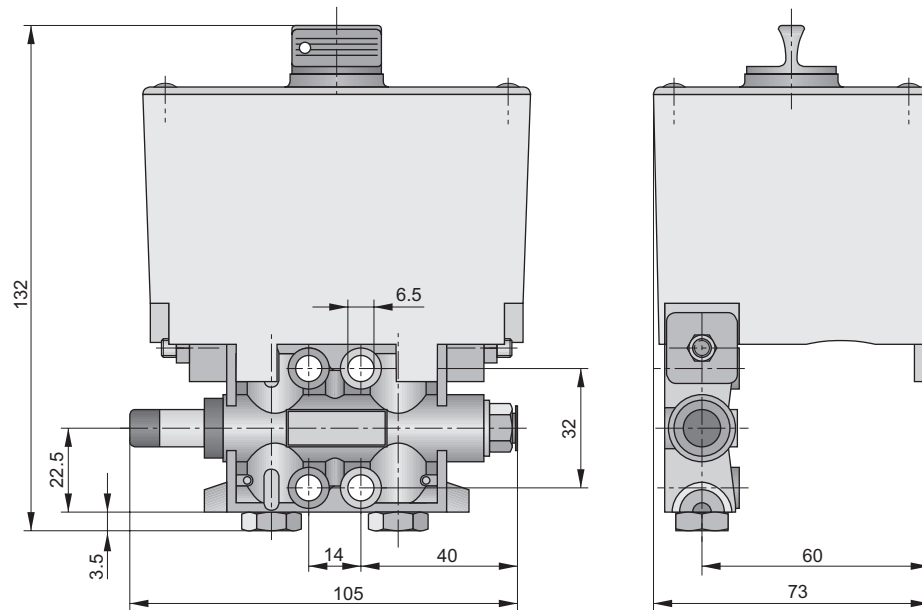

Injection lubricator combination Type: LB31, LB33

This combination, comprising an oil reservoir and three-point lubricator element (LB 31 for group activation and LB33 for individual activation), is used to lubricate compressed air cylinders, synchronized feed devices or compressed air tools.

Type: LB31, LB33

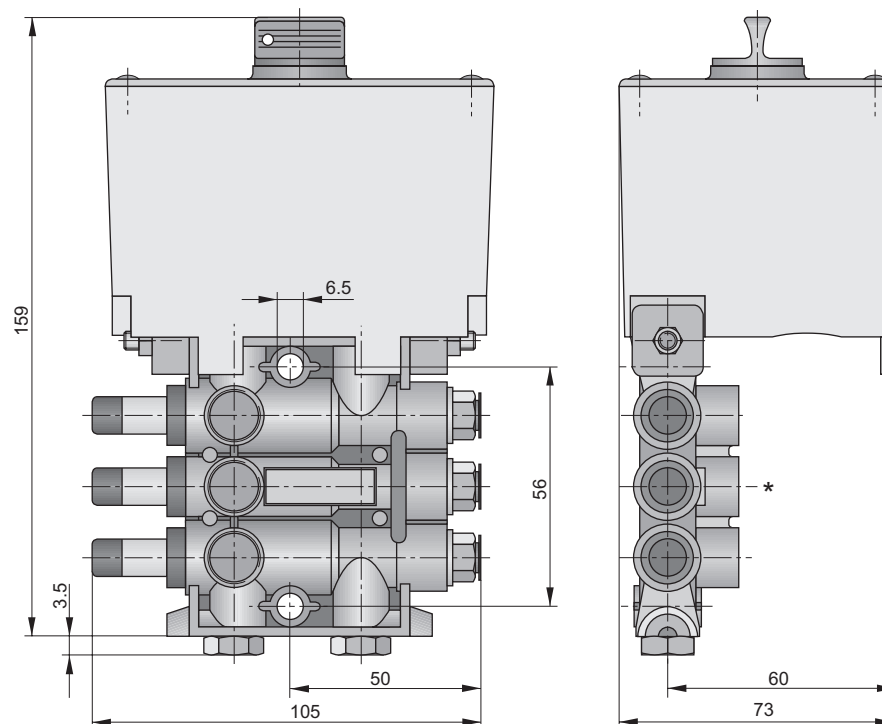

* 3 lateral connections G1/8 only with type LB33

For order instructions see page 183, for characteristics see page 168–172, for accessories see page 178–183



Dimensions in mm

Type: LUI-08, 10, 15, 20, 25

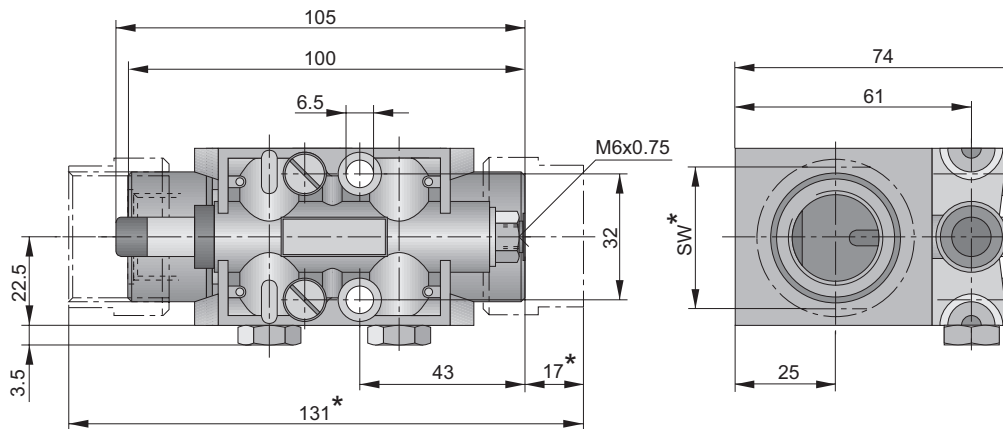

* Only for LUI-20 SW=36
LUI-25 SW=41

Injection lubricator system

Series oilfit

Dimensions

Injection lubricator combination type: LUI

This combination, comprising a single-point lubricator element and flow sensor, without oil reservoir, is used to lubricate compressed air cylinders, synchronized feed devices or compressed air tools. The pressurized oil supply is located within the air outlet of the flow sensor.

Type: L10i, L10e

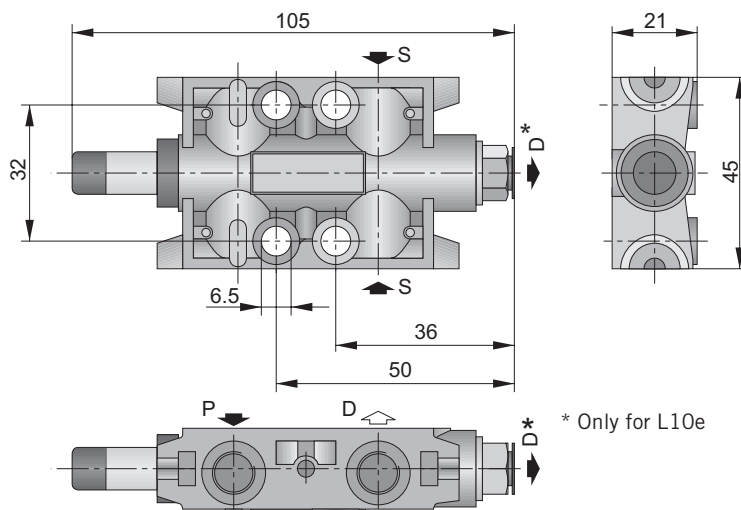

D = pressure oil line
S = suction line (from oil reservoir)
P = pilot air (from air flow sensor)

Injection lubricator element Type: L10i, L10e

The lubricator elements have a plain lateral air inlet and can only be used for flange-mounting to the flow sensor.

For order instructions see page 183, for characteristics see page 168–172, for accessories see page 178–183

Dimensions in mm

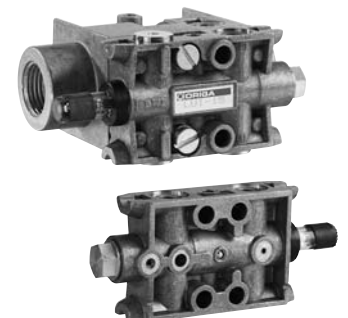

Injection lubricator system

Series oilfit

Dimensions

Injection lubricator elements
Type: L11, L31, L33

Lubricator elements for flanging to the reservoir or for extending a lubricator combination

Type: L11

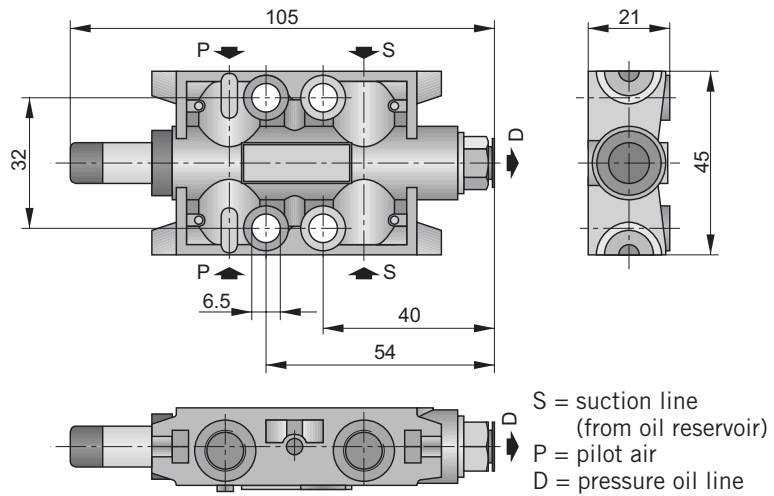

Type: L31, L33

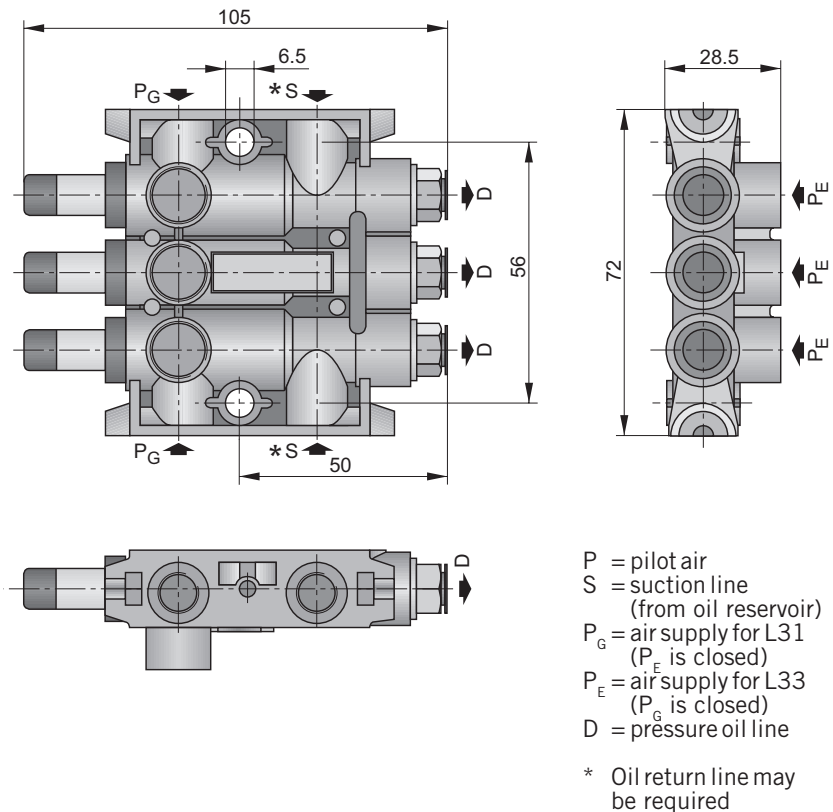

For order instructions see page 183, for characteristics see page 168–172, for accessories see page 178–183

Dimensions in mm

Injection lubricator system

Series oilfit

Order instructions

Standard versions

Description	Port size	Order instruction	
		Type	Order No.
Injection lubricator combinations with oil reservoir	G1/4	LUBI-08	PB 13449-005
	G3/8	LUBI-10	PB 13549-005
	G1/2	LUBI-15	PB 13649-005
	G3/4	LUBI-20	PB 13749-005
	G1	LUBI-25	PB 13849-005
	G1/4	LUBE-08	PB 13449-007
	G3/8	LUBE-10	PB 13549-007
	G1/2	LUBE-15	PB 13649-007
	G3/4	LUBE-20	PB 13749-007
	G1	LUBE-25	PB 13849-007
		LB11	PB 13049-000
		LB31	PB 13149-000
		LB33	PB 13249-000
Injection lubricator elements	G1/4	LUI-08	PB 13449-001
	G3/8	LUI-10	PB 13549-001
	G1/2	LUI-15	PB 13649-001
	G3/4	LUI-20	PB 13749-001
	G1	LUI-25	PB 13849-001
		L10i	KY 2030
		L10e	KY 2031
		L11	KY 2033
		L31	KY 2032
		L33	KY 2034

For accessories see page 178–183

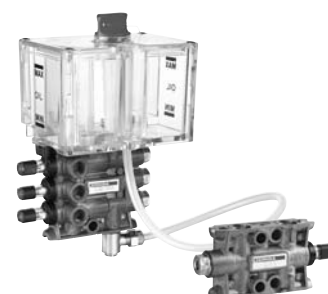

Injection lubricator system

Series oilfit

Accessories

Dimensions

Air flow sensor Type: U-08, 10, 15, 20, 25
For injection lubricator elements Type L10i and L10e

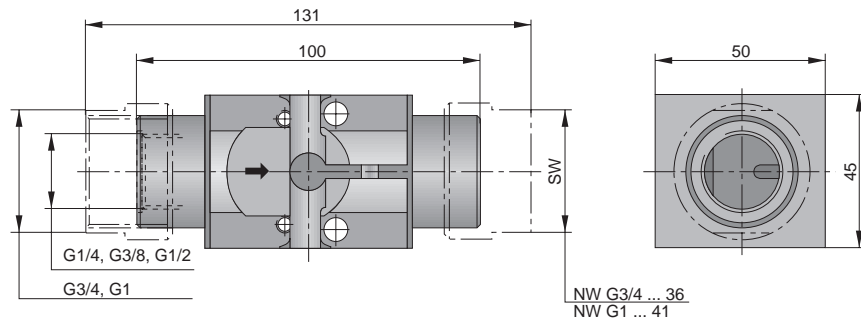

Air flow sensor

The airflow sensor converts air flow into a digital air signal.

Oil reservoir

The reservoir provides oil supply for one or more lubricator elements.

Characteristics – Oil reservoir

Type	Bi
Port size	Without thread, Directly flange mountable to lubricator element
Installation	Vertical, filling plug on top (see drawing)
Mounting	With coupling kit to lubricator element
Oil capacity	250 cm ³
Oil supply	Without pressure (gravity feed)
Material	Polyester resin (PETP)

Oil reservoir Type: Bi

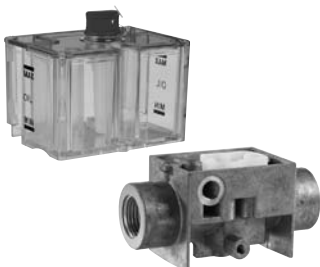
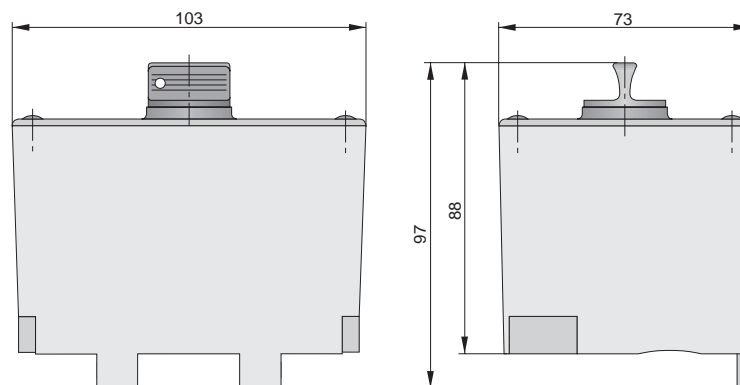

For order instructions see page 183, for characteristics see page 168–172, for accessories see page 178–183

Dimensions in mm

Connection kit, 12 parts – Type: A

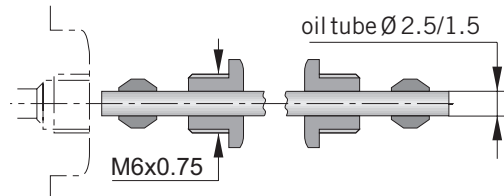

Oil tube – Type: S

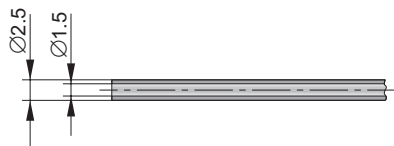

Coupling kit – Type: K

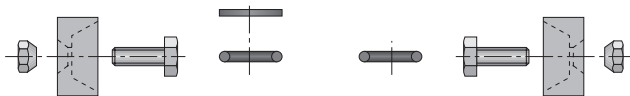

Special oil for lubricators, VG32 to ISO 3448



Order No. KY8786

For more information see page 191

Injection lubricator system

Series oilfit

Accessories

Dimensions

Connection kit 12 parts

The connection kit consisting of 12 parts (for 3 pressure oil lines) is used for connecting pressure oil tubes with the lubricator element and the discharge element.

Oil tube

Connects the lubricator element with the oil discharge element on the unit to be lubricated (tool, cylinder). Material: polyamide (PA) supplied in lengths of 10 m, prefilled with oil and ends plugged.

Coupling kit

The coupling kit is used for assembling all the components of the system.

For order instructions see page 183, for characteristics see page 168–172, for accessories see page 178–183

Dimensions in mm

Injection lubricator system

Series oilfit

Accessories

Dimensions

Air connection with oil injector

The air connection with oil injector connects the pressure oil line to the air line of a pneumatic unit (e.g. screws directly into a cylinder port).

Air connection with oil injector – Type: E-06, E-08

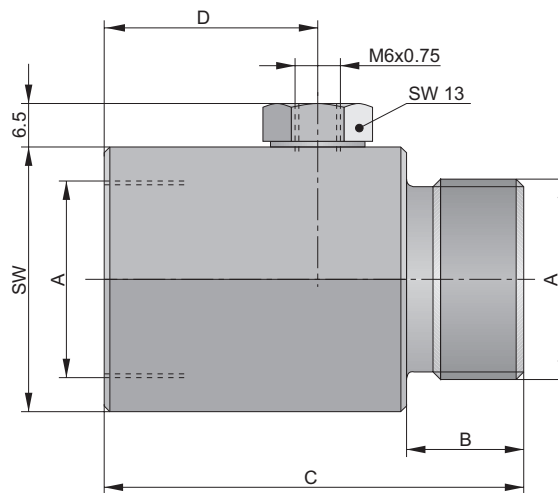

Dimension table

Type	A	B	C	D	SW
E-06	G1/8	8	35	17	22
E-08	G1/4	12	45	22	22

Oil injector, single

Oil injector with check valve for pressure oil line.

Oil injector, single – Type: E₀

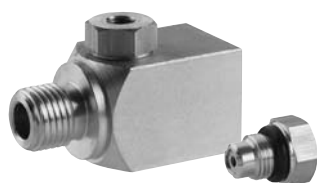
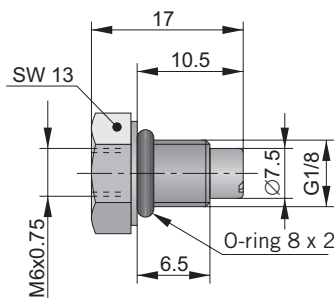

For order instructions see page 183, for characteristics see page 168–172, for accessories see page 178–183

Dimensions in mm

Characteristics – Atomizer

Adjustment of oil feed	With setting screw in the back of the housing
Oil connection	G1/8 for discharge element E ₀
Air connection	G1/8
Spray angle	Conical

Injection lubricator system

Series oilfit

Accessories

Dimensions

Flexible atomizer – Type: B-101

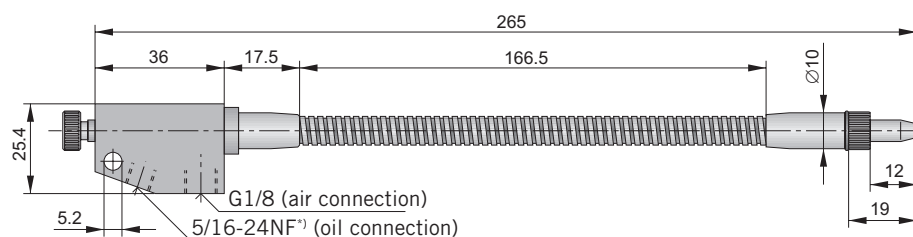

Atomizer

Adjustable atomizer for all kinds of spraying operations (continuous jet).

Versions:

- Flexible atomizer
- Rigid atomizer

*) Adapter 5/16-24 NF to G1/8 Type: B-6056 (see order instructions)

Rigid atomizer – Type: B-102

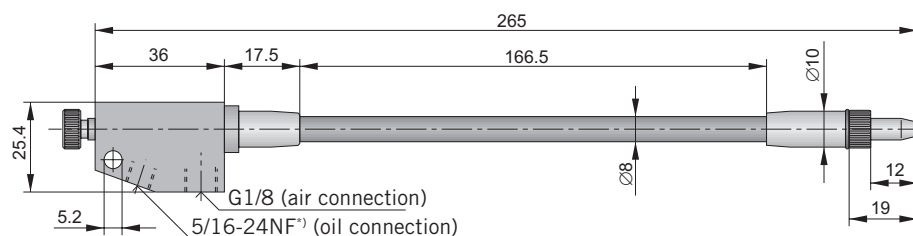

*) Adapter 5/16-24 NF to G1/8 Type: B-6056 (see order instructions)

Oil injector, single

Oil injector with check valve for pressure oil line.

For order instructions see page 183, for characteristics see page 168–172, for accessories see page 178–183

Dimensions in mm



Injection lubricator system

Series oilfit

Accessories

Dimensions

Oil reservoir with sight glass
Capacity: 4 l

The oil reservoir supplies one or more injection lubricators.

Characteristics	Symbol	Unit	Description
Type			B-04
System			Oil reservoir for gravity feed of one or more injection lubricators
Connection			Thread
Port size			Inlet: M16 x 1.5 Outlet: G3/8
Installation			Vertical (see drawing)
Mounting			4 M8 screw, mounting brackets are included in delivery
Oil capacity		cm ³	4000
Oil supply			Unpressurized
Weight (mass)		kg	4.50

Oil reservoir, unpressurized - Type: B-04

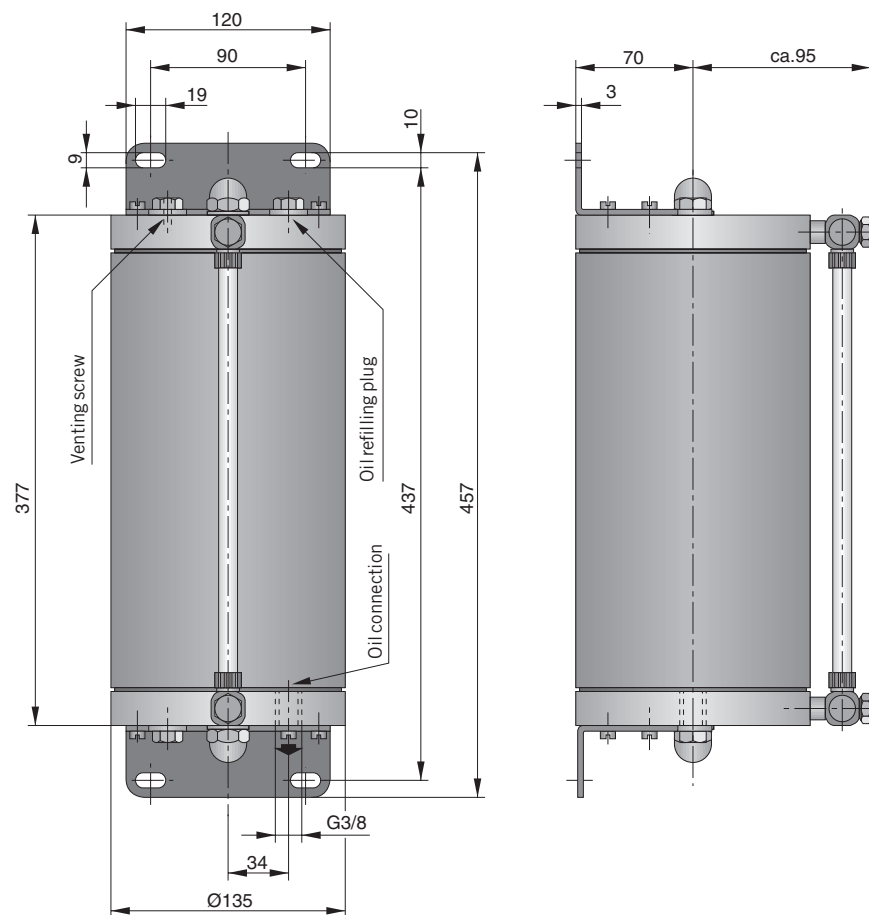

For order instructions see page 183, for characteristics see page 168–172, for accessories see page 178–183

Dimensions in mm

Accessories

Description	Port size	Order instructions	
		Type	Order No.
Converter	G1/4	U-08	PL08144
	G3/8	U-10	PL08109
	G1/2	U-15	PL08110
	G3/4	U-20	PL08111
	G1	U-25	PL08112
Coupling kit (9-part)		K	PL08066
Connection kit (12-part)		A	PL08185
Oil tube, prefilled with oil, length 10 m		S	PL08187-10
Air connection with oil injector	G1/8	E-06	PL08100
Air connection with oil injector	G1/4	E-08	PL08101
Oil reservoir, flangeable to lubricator element		Bi	PL08108
Special oil for oil mist lubricators see page 191			KY8786
Oil injector	G1/8	E _o	PL08091
Flexible atomizer	G1/8	B-101	KY9919
Rigid atomizer	G1/8	B-102	KY8783
Oil reservoir, 4l		B-04	PL15534
Adapter 5/16-24NF	G1/8	B-6056	KX6026

Injection lubricator system

Series oilfit

Order instructions

Accessories

